

1924 FALL AND WINTER 1925

FORD OWNERS SUPPLY BOOK

Save
20% to 50%
*Satisfaction or
Money back*



Western Auto Supply Co.

KANSAS CITY, MO.
LAS, TEXAS
MONTA, GA.
STON, TEX.

Kansas City

1422-1424 GRAND AVE.

ST. PAUL, MINN.
DES MOINES, IA
WICHITA, KANS.
TOPEKA, KANS.

Quicker Service Lower Prices Better Quality

Our Direct-from-Factory-to-Car-Owner system of distribution and enormous buying power enable us to furnish strictly high quality, standard brand supplies at the lowest possible prices. Our convenient locations mean quicker service and lower transportation charges.

Satisfaction or Money Back.



One of Our Houses is located near You Western Auto Supply Co.

World's OLDEST and LARGEST Exclusive Auto Accessory House

KANSAS CITY, MO. 1422-1424 GRAND AVE.	DALLAS, TEX. 2000 COMMERCE ST.	ST. PAUL, MINN. 60 EAST 6TH ST.	DES MOINES, IA. 923 LOCUST ST.
MINNEAPOLIS, MINN. 900 HENNEPIN AVE.	WICHITA, KANS. 127 SO. LAWRENCE	ATLANTA, GA. 187 PEACHTREE ST.	HOUSTON, TEX. 1122 MAIN ST.
LITTLE ROCK, ARK. COR. 3RD & LOUISIANA (OPEN OCT. 15TH)	MEMPHIS, TENN. COR. MONROE & 3RD (OPEN OCT. 1ST)	SAN ANTONIO, TEX. 112-114 BROADWAY (OPEN NOV. 1ST)	

OUR POLICY

When we receive your money for an article in our catalog, we don't consider that the money belongs to us, but is still yours and subject to be returned to you until after you have received your purchase and found it exactly as illustrated and described.

Our business was established and is being built up on the solid foundation of **Absolute Honesty and Satisfaction**. A vast army of thousands of satisfied customers and friends in nearly every state in the Union, gained by honest goods, low prices and fair dealing, stands to-day as a reward to our unflinching fidelity to this policy.

We employ a large force of competent people in all departments, who give your orders careful and prompt attention, but if for any reason an error should be made, we want you to write us fully and give us an opportunity to make it good. We are always at your service and assure you that your orders will always receive prompt and careful attention. You will be treated just as we should like to be if we were in your place.

Western Auto Supply Co.

Ron C. Davis

PRESIDENT

OUR TERMS

Cash with order or C. O. D. We will allow examination if requested on C. O. D. express or freight shipments, but the postal rules will not permit Parcel Post C. O. D. packages to be opened or examined.

OUR REFERENCES

If you wish to know more about our responsibility, write any bank in any city where we have a store, or consult Dun or Bradstreet Commercial Agency. Any local bank in your town that has the commercial agency service can tell you our standing.

REMITTANCES

We prefer Express or Postoffice Money Order or Draft, Kansas City, Chicago or New York exchange, as we do not have to pay exchange on them. If you live on a rural route and want to send a Postoffice Money Order, your mail carrier will buy a money order for you and mail it to us. Just give him your letter and the money, and he will do the rest. **If you send currency**

be sure to register letter. We will accept postage stamps for amounts under \$1.00.

Where shipment is to go by Parcel Post, always include sufficient postage and 5c for insurance. See Parcel Post rate table below. If you send too much, balance will be returned to you.

RETURNED GOODS AND EXCHANGES

Don't fail to write us fully regarding any unsatisfactory goods before returning to us, as we can often furnish some missing or necessary part.

Returned goods should be securely packed to prevent any breakage and insure prompt and safe arrival. Mail us a letter at the same time of shipment, giving full particulars, and don't fail to put your name and P. O. address on package. When returning goods by Parcel Post, be sure to put on sufficient postage. Don't seal the package or place stamps over the strings, as this would make it first-class matter, requiring a much higher rate of postage.

Prices shown in this catalog are subject to change without notice.
This catalog supplements all previous issues.

FIGURE PARCEL POST CHARGES FROM THIS CHART.

How Far Do You Live from Our Store? 	If you live in Zone 1 Not more than 50 miles from Our Store	If you live in Zone 2 Over 50 miles—not more than 150 miles from Our Store	If you live in Zone 3 Over 150 miles—not more than 300 miles from Our Store	If you live in Zone 4 Over 300 miles—not more than 600 miles from Our Store	If you live in Zone 5 Over 600 miles—not more than 1000 miles from Our Store
For weights up to 1 pound, the postage is.....	5c	5c	6c	7c	8c
For each additional pound or fraction of a pound, add.....	1c	1c	2c	4c	6c

Example: If you live in the 3rd zone and order merchandise weighing 10 pounds, the parcel post charge is 6c for the first pound and 2c for each of the nine additional pounds (18c), making a total of 24c.

BE SURE TO SEND

plenty of money to cover postage if you want goods sent by Parcel Post. If you send too much, we will return all that is not needed for postage and insurance.

We suggest having all Parcel Post packages insured, no matter how small the value. The cost is only 5 cents and in case it is lost then neither we nor the customer must stand the loss. Always include 5 cents extra for insurance.

Western Standard

Western Standard Fabric Tires are built exclusively for us by a big reliable factory out of the finest materials and by the latest improved process of manufacture. They are big, strong, sturdy tires, full standard weight and size, with an extra thick, tough tread and strong side walls and with a very neat and effective non-skid design, embodying the vacuum principle, which is now universally recognized as the best for slippery pavements as well as country roads. You can rely on them for service.



GUARANTEED

Fabric Tires

WESTERN AUTO SUPPLY CO.

FABRIC

Every tire shown on this page can now be shipped to any point in the United States by parcel post, insuring safe and quick delivery at the trivial cost of only a few cents per pound.

Our enormous buying power enables us to take practically the entire factory output and by offering these tires through our "Direct-from-Factory-to-Car-Owner" system of distribution, eliminating the cost of traveling salesmen, national advertising and distributors' profits, we are able to offer Western Standard Fabric tires at a price below the average local dealer's cost. Get your tires direct from us and assure yourself of getting full value for every dollar.

Every Western Standard tire is strictly first grade, full standard size and weight, brand new fresh stock and guaranteed for 6,000 miles against defects of workmanship or material.

Save \$5⁰⁰ to \$16⁰⁰ on every tire

DIRECT FROM FACTORY TO YOU

SIZE	STOCK NUMBER	SHIPPING WEIGHT	OUR PRICE Tax Paid	SIZE	STOCK NUMBER	SHIPPING WEIGHT	OUR PRICE Tax Paid
30x3	X8660	10½ lbs.	\$ 5.65	31x4 ss.	X8664	20 lbs.	\$ 9.95
30x3½	X8661	13 lbs.	6.55	32x4	X8665	21 lbs.	11.45
32x3½	X8662	16½ lbs.	8.75	33x4	X8666	22 lbs.	11.95
31x4 cl.	X8663	20 lbs.	9.65	34x4	X8667	23 lbs.	12.35

Send us your order for as many tires as you need. When they come, compare them with any tire you have ever used. Inspect them thoroughly—feel the thick tough live tread, note their big strong sturdy construction, then if for

any reason you decide not to keep them, return them to us and we will refund every cent you paid.

Or if you prefer, we will ship the tires C. O. D. on approval, without one cent deposit.

6,000 MILES

Wear-well CORD TIRES



30x3½
CORD
\$7.45

GUARANTEED

SAVE 20% to 40% ON CORD TIRES

Cord Tires are becoming more and more popular all the time, because they are stronger, more resilient and easier riding, and will stand more knocks and rough usage than fabric tires.

When you consider that a good cord tire will give about 50 per cent more mileage than an ordinary fabric tire, cord tires are the cheapest tires you can use, not to mention the added satisfaction of better service and less annoyance from tire trouble.

It costs more to build a good cord tire than it does a fabric tire, but through the increased demand and our enormous buying power and increased factory production, we are able to offer you our Wear-well Cords for very little more than the price of fabric tires.

SAVE \$5⁰⁰ TO \$18⁰⁰ ON EVERY TIRE

(Depending upon the size you use)

Wear-Well Cord Tires are made for us under our own specifications by one of the oldest and most reliable tire factories in the country. The very best grades of materials are used, together with latest improved scientific processes of manufacture. The tread has one of the most effective non-skid designs ever used, and is built up broad and thick, to stand hard service and give long wear.

Wear-Well Cords are full oversize and weight in all sizes shown, except 30x3, 32x3½ and one style of 30x3¼ clincher, which are standard fabric size and weight, so they can be used alongside any fabric tire or other standard size cord.

Direct From Factory to You

Wear-Well Cord Tires are priced low, because they are made especially for us in large quantities, and sold direct to the user, eliminating all unnecessary profits and selling expenses. Here is your opportunity to get high-grade cord tires, fully guaranteed, for even less than the price you are usually asked for ordinary fabric tires.

Send us an order for as many Wear-well Cord Tires as you need. When they come, examine them thoroughly, notice their heavy, strong, sturdy construction, and feel the thick, tough tread, the effective non-skid design, the strong, heavy sidewalls and beads. Then, if you are not convinced that they are the best tire value you ever saw, return them to us and we will gladly refund every cent you paid.

Tires Shipped on Approval Without Deposit

We will also ship Wear-well Cords anywhere C. O. D. on approval, without one cent deposit. Any size tire can now be shipped to any point in the United States by Parcel Post.

GUARANTEED 10,000 MILES

We guarantee Wear-Well Cord Tires against defects in materials or workmanship on a basis of 10,000 miles' service (regular standard size 30x3, 30x3¼ and 32x3½, 8,000 miles). We will repair or relace any DEFECTIVE casing on the above basis, charging only for the mileage received from the tire.

Reduced Prices

WEAR-WELL CORD TIRES

Full Oversize (except sizes noted)

Size	Style of Bead	Shipping Weight	Our Price Tax Paid
30x3	Cl. (St'd size)	11 lbs.	\$ 6.95
30x3½	Cl. (St'd size)	13 lbs.	7.45
30x3¼	Cl. (Oversize)	14 lbs.	8.45
30x3½	SS (Oversize)	14 lbs.	9.35
32x3½	SS (St'd size)	16 lbs.	10.75
31x4	SS (Oversize)	19 lbs.	11.75
32x4	SS (Oversize)	20 lbs.	13.35
33x4	SS (Oversize)	21 lbs.	13.95
34x4	SS (Oversize)	22 lbs.	14.45
32x4½	SS (Oversize)	24 lbs.	16.95
33x4½	SS (Oversize)	25 lbs.	17.35
34x4½	SS (Oversize)	26 lbs.	17.95

Every Wear-well Cord Tire is strictly first quality, new, fresh stock bearing manufacturer's serial number and guarantee.

10,000 MILES

WESTERN GIANT

The 12,000

Construction
Extra Thick
Vacuum Type
Non-Skid Tread
Six Plies of
Heavy Cord
Extra Thick
Side Wall
Full Oversize

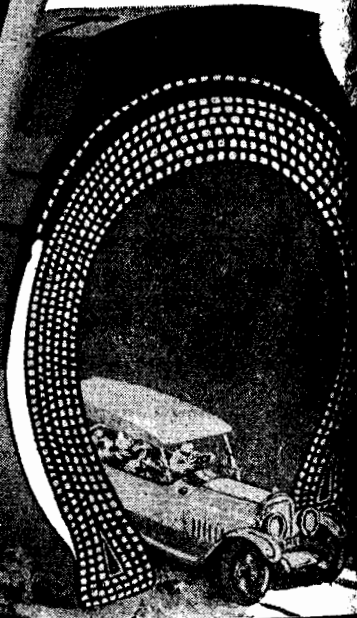

THE BIG STRONG

CORD TIRES

MILE TIRE

**YOU CAN PAY HIGHER PRICES BUT
YOU CAN'T BUY BETTER TIRES**

In buying tires it pays to get the best, even though they cost a little more. The service and pleasure you receive from your car depend more directly on the quality of your tires than anything else about your car. More and more, experienced car-owners are demanding better tires. That is why the cord tire was developed, and why cords are now used as regular factory equipment on 90 per cent of the best automobiles made.

**WESTERN GIANT CORDS ARE THE GREATEST
TIRE VALUE EVER OFFERED**

It costs more to build a cord tire than it does to make a fabric tire; and it costs more to build a good cord than it does an inferior one. When we decided to build Western Giant Cord Tires to bear our name, we determined to make the best tire that money could buy. No expense has been spared to secure the best materials obtainable. One of the best factories in the country was selected to build them, a factory with an enviable reputation of twelve years for building highest quality tires.

**12,000 MILE CORD TIRES FOR LESS
THAN OTHERS ASK FOR FABRIC TIRES**

All this costs more, but it assures us of getting a tire of the highest quality, which we can recommend to our customers and stake our whole reputation on. The result has been such a demand for Western Giant Tires that we have more than doubled factory production, and this, together with our direct-from-factory-to-car-owner system of distribution, enables us to offer Western Giant Super-Quality 12,000-mile Cords for less than many others ask for the most ordinary grades.

Notice especially the thick, flat, heavy tread, which provides nearly twice as much wearing surface as the ordinary rounded tread tire, and so tough that it will show almost no wear whatever after thousands of miles of service. Also, the special non-skid design of vacuum cups with high tapering bars, which holds securely on slippery pavements and provides safety without the use of tire chains.

**GUARANTEED FOR 12,000 MILES OF HONEST
SERVICE**

Every Western Giant Cord Tire is built full oversize, and is carefully inspected and guaranteed for 12,000 miles of good honest service—one of the longest and strongest guarantees ever given on any tire.

We know, of course, that there are many tires on the market offered at slightly less than our prices, but that comes back to a question of quality and service. The real cost of a tire is not the amount of money you pay for it at the start, but is the cost per mile of service received—that is, the number of miles' service that you receive for the price paid for the tire. On this basis, Western Giant Cord Tires are not only the best tires you can use, but the cheapest.

Send us your order for a Western Giant Cord Tire, or as many as you need. When they come, examine them carefully and compare them with the tires you have been using or with any other tire on the market. Compare the thickness, the weight, the toughness, every point that makes for tire quality and service. Then if you are not fully satisfied that Western Giant Cords are the best tires you ever saw, just send them back to us, and we will promptly refund every cent you paid, along with all transportation charges.

**TIRES SHIPPED ANYWHERE ON APPROVAL
WITHOUT DEPOSIT**

We will also ship tires anywhere C. O. D. on approval without one cent deposit. Any size tire can now be shipped to any point in the United States by parcel post. Let your next tires be Western Giant Cords.

WESTERN GIANT CORD TIRE PRICES FULL OVERSIZE

Size	Bead	Ship. Wt.	Price
30x3½	Clincher	15 lbs	9.95
32x3½	S. S.	18 lbs	12.35
31x4	S. S.	22 lbs	15.85
32x4	S. S.	23 lbs	16.95
33x4	S. S.	24 lbs	17.85
34x4	S. S.	25 lbs	18.35
32x4½	S. S.	32 lbs	22.65
33x4½	S. S.	33 lbs	23.65
34x4½	S. S.	34 lbs	24.65
33x5	S. S.	38 lbs	28.65
35x5	S. S.	41 lbs	29.85

GUARANTEED 12,000 MILES

We guarantee Western Giant Cord Tires against defects in materials or workmanship on a basis of 12,000 miles' service. We will repair or replace any DEFECTIVE casing on the above basis charging only for the mileage received from the tire.

STURDY CORD

**30x3½
OVER-SIZE
\$9.95**

WESTERN GIANT Balloon-Type Cords



30x3½ CL.
\$10⁹⁵

RIDE EASIER—SAVE YOUR TIRES
The balloon tire has become the outstanding feature of present-day motoring, because of the marvelous improvement it makes in riding comfort. These big over-size tires under low air pressure, do not "float over" the bumps, without in turn to tires or shaking up the occupants. Balloon tires save springs and axles, lengthen life of the motor and diminish depreciation of entire car. Skidding is greatly reduced, while sudden braking or unexpected turns balloon tires are of great value.

FIT YOUR PRESENT RIMS WITHOUT CHANGE

It is not necessary to change your present wheels or rims to install Western Giant Balloon-Type Cords. They are full standard balloon-type size, but are made to fit without change the sizes shown in the price list below. They will not interfere in any way with fenders or brakes, and affect the gear ratio of your car or speedometer.

It is not even necessary to install a full set of balloon tires in that way. You can install balloon-type on your rear wheels first, using your regular tires on the front wheels until they are worn out.

**GUARANTEED 12,000 MILES
REDUCED PRICES**

Western Giant Balloon Type Cords are made especially for us by one of the best tire factories in the country. We know exactly how they are made and what they will do. We guarantee them against defect on the basis of 12,000 miles' service. Our big buying power and Direct-from-Factory-to-Car-Owner method of distribution enable us to quote the lowest money-saving prices.

Note: Being over-size, these tires require the next larger size of inner tube.

Showing
How the
Balloon
Tire
Absorbs
Bumps



Balloon Tire Comfort at Regular Tire Costs

<p>30x3½ CL. \$10⁹⁵ LIST PRICE \$17⁰⁰ SHIP. WT. 16 lbs.</p>	<p>30x3½ S.S. \$12⁹⁵ LIST PRICE \$20⁰⁰ SHIP. WT. 17 lbs.</p>	<p>31x4 S.S. \$16⁸⁵ LIST PRICE \$25⁰⁰ SHIP. WT. 23 lbs.</p>	<p>32x4 S.S. \$17⁸⁵ LIST PRICE \$26⁰⁰ SHIP. WT. 24 lbs.</p>
<p>33x4 S.S. \$18⁶⁵ LIST PRICE \$28⁰⁰ SHIP. WT. 25 lbs.</p>	<p>32x4½ S.S. \$22⁶⁵ LIST PRICE \$34⁰⁰ SHIP. WT. 33 lbs.</p>	<p>33x4½ S.S. \$23³⁵ LIST PRICE \$35⁰⁰ SHIP. WT. 34 lbs.</p>	<p>34x4½ S.S. \$23⁶⁵ LIST PRICE \$33⁰⁰ SHIP. WT. 35 lbs.</p>

Western Standard INNER TUBES

30x3
GRAY
\$1.15

Standard Size
Standard Weight
Standard Quality

Western Standard tubes are made exclusively for us by one of the largest manufacturers in the country. They are made of the best materials by the latest well-known scientific laminated method of construction, which prevents trouble with slow leaks. They are extra strong at the splice and around valve stem and fitted with the highest quality standard valves.

FULLY GUARANTEED

Every tube is thoroughly inspected and tested before it leaves the factory and is absolutely guaranteed against any defects of workmanship or material. Furnished in all of the popular sizes in either gray or red. Strictly new fresh stock.

Thousands of our customers have been using these tubes in over-size cord tires of the same size and getting excellent service. However, when getting tubes for over-size cord tires, we recommend the use of either our extra thick Double Service gray tube or our Jumbo Double thick tubes shown on the two following pages.

Good inner tubes are absolutely essential for satisfactory tire service. It pays to use good tubes.

Western
Standard
TUBE
SIZE 30x3 1/2
Western Auto Supply Co.
KANSAS CITY ST. PAUL DALLAS - OKLAHOMA

Western Standard

30x3 1/2

WESTERN STANDARD RED TUBES

Stock Number	Size	Price Each	Ship Wt.
E6457	28x3	1.19	2 1/2 lbs
E6450	30x3	1.42	2 1/2 lbs
E6451	30x3 1/2	1.42	3 lbs
E6452	32x3 1/2	1.66	3 1/2 lbs
E6453	31x4	1.85	3 1/2 lbs
E6454	32x4	1.95	3 1/2 lbs
E6455	33x4	2.05	4 lbs
E6456	34x4	2.10	4 lbs
E6458	32x4 1/2	2.45	4 1/2 lbs

WESTERN STANDARD GRAY TUBES

Stock Number	Size	Price Each	Ship Wt.
E6447	28x3	.99	2 1/2 lbs
E6440	30x3	1.15	2 1/2 lbs
E6441	30x3 1/2	1.25	3 lbs
E6442	32x3 1/2	1.48	3 1/2 lbs
E6443	31x4	1.68	3 1/2 lbs
E6444	32x4	1.75	3 1/2 lbs
E6445	33x4	1.85	4 lbs
E6446	34x4	1.89	4 lbs
E6448	32x4 1/2	2.15	4 1/2 lbs

E6460—Universal Red Tube for Fords; fits both 30x3 and 3 1/2 (Simp. wt., 3 lbs.) 1.38

FORD OWNERS—UNIVERSAL

SIZE FITS BOTH 30x3 & 3 1/2 E6460 WT. 3lbs. \$1.38 SPECIAL EACH

Double Service

EXTRA THICK GRAY TUBES

GUARANTEED 18 MONTHS AGAINST DEFECTS

Tubes are one of the most important things that you use about your car. No matter how good your casings may be, you cannot expect satisfactory tire service and mileage unless you use good tubes of the proper size. In buying inner tubes it pays to use the best, even if they do cost a little more.

EXTRA THICK AND STRONG

Double-Service Tubes are made exclusively for us by manufacturers of long experience. They are made of the best materials and by the latest scientific "laminated" process which does away with slow leaks—built layer upon layer of live, fresh, strong, pure rubber, then all vulcanized together into one strong and solid, leak-proof tube, absolutely airtight. Extra strong at splice and valve stem.

Double-Service Tubes are extra thick and strong, with highest quality valves. Every tube is thoroughly inspected and tested before it leaves the factory, and is absolutely guaranteed against defects of material or workmanship. Furnished in all popular sizes. New, fresh, live stock.

FOR CORD OR FABRIC TIRES

Double-Service Extra Thick Gray Tubes are built stronger and heavier than ordinary tubes, so that they can be used in oversize cord tires without extra strain. The use of these tubes will add to the mileage of your casings.

Include one of these tubes in your next order, examine it when it arrives, and if you don't find it the best tube for its price that you have ever seen, just send it back and we will refund every cent you paid.

DOUBLE SERVICE TUBE
WESTERN
AUTO SUPPLY CO.
KANSAS CITY DALLAS ST. PAUL

30x3½
\$1.70

\$1.48 30x3

OUR REDUCED PRICES

Stock Number	Size	Price Each	Ship. Wt.	Stock Number	Size	Price Each	Ship. Wt.
E6470.....	30x3	1.48	3 lbs.	E6475.....	33x4	2.35	4½
E6471.....	30x3½	1.70	3½ lbs.	E6476.....	34x4	2.40	4½
E6472.....	32x3½	1.90	3½ lbs.	E6477.....	32x4½	2.80	5
E6473.....	31x4	2.20	4 lbs.	E6478.....	33x4½	2.90	5
E6474.....	32x4	2.30	4 lbs.	E6479.....	34x4½	2.95	5

For CORD or FABRIC TIRE

JUMBO EXTRA THICK TUBES

GUARANTEED FOR TWO YEARS

**MORE THAN 50% HEAVIER THAN
STANDARD WEIGHT TUBES**

FOR CORD OR FABRIC TIRES

Most car owners have learned that the real secret of satisfactory and economical tire service is to use good inner tubes. No matter how good your tires are they are useless without good tubes. The Jumbo tube has been made up to our special order to supply the demand of many car owners who want a tube thicker, heavier and better than the regular brands. Our "JUMBO" is what the name implies, a tube about 50% thicker and heavier than others. The advantages are that it will not pinch or puncture as easily as regular weight tubes and it will stand more hard use and abuse. It will cost less in the end than ordinary cheap tubes, also give you much

more satisfactory service while using it. This tube is laminated or made up from several layers of thin rubber, all rolled together and vulcanized into one body, which precludes all possibility of porous rubber and does away with slow leaks and the necessity of pumping up often. Our "JUMBO" tube is made of the very finest material obtainable and is well worth the extra amount it costs. Just the tube for oversize tires or cord tires, as it will stretch sufficiently to fill them without straining the tube. **Guaranteed for two years against defects.** Equip your casings with "JUMBO" RED TUBES and forget tube trouble. Average shipping weight, 4 pounds.

OUR REDUCED PRICE—JUMBO RED INNER TUBES

E6480—30x3	1.98	E6487—34x4	3.20
E6481—30x3½	2.28	E6488—32x4½	3.65
E6483—32x3½	2.48	E6493—33x4½	3.95
E6484—31x4	2.95	E6489—34x4½	4.15
E6485—32x4	2.95	E6494—33x5	4.75
E6486—33x4	3.00	E6491—35x5	4.95

Do not confuse this Big Extra Thick Red Tube with the cheap compounded tubes offered by other mail-order houses at slightly lower prices.

SPECIAL FOR FORDS

UNIVERSAL SIZE FITS 30x3 AND 30x3½ TIRES. FITS BOTH FRONT AND REAR TIRES ON FORDS.
E6482—Heavy Red Jumbo extra thick Tube, wt. 4 lbs.

\$2.20

30x3½
RED
\$2.28

Q This illustration shows the comparative thickness of a "JUMBO" RED TUBE with an ordinary tube. A "JUMBO" RED TUBE, in small sizes, is about the thickness of a silver dollar.

Q In small sizes an ordinary tube is only about the thickness of a silver quarter.

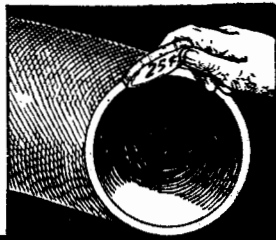
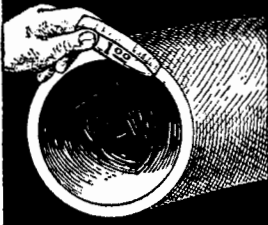

\$1¹⁹ Genuine Shaler 5 Minute Vulcanizer



The Shaler Five-Minute Vulcanizer mends all tube punctures performing repairs far superior to any "stuck-on" patch. Heat is produced by burning a non-flaming chemical heating unit.

Each of the twelve patch units furnished with the outfit is complete itself, consisting of the patent heat unit in its metal container, and the piece of raw rubber attached to the vulcanizing surface of the container. The cartridge is clamped over the puncture and the heat unit is lighted. In five minutes the repair is done. Only the patch is heated. Anyone can use with no danger of overcuring. Each outfit includes Vulcanizer, 6 round and 6 oblong patch units packed in box. This outfit should not be confused with cheaper outfits which use round patches only and can therefore be sold at a lower price. It pays to get the best—saves time and trouble. Regular price, \$1.50.

- Our Reduced Price**
- E6330—Each, complete with patches. Shipping weight, 1 lb. 1
 - E6331—Box of 12 Oblong Patches and Heat Discs. Shipping weight, 8 ounces..... 1
 - E6332—Box of 12 Round Patches and Heat Discs. Shipping weight, 8 ounces..... 1

Vulcanizing Rubber

For Tubes and Casings

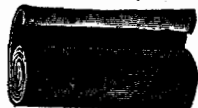

We handle only a very high grade of raw rubber. It comes in three kinds: the regular **Tube Stock** for repairing punctures in tubes; the **Combination Stock**, cured on one side, for placing inside of tubes to

repair large holes or long splits; and **Tread Stock** for repairing cuts in casings. Can be used with either small portable vulcanizers or large shop vulcanizers.

Note:—Don't confuse our vulcanizing rubber with cheap compounded stock offered by some houses. It never pays to use cheap grade repair stock.

Our Reduced Price

- E6296—Tread Stock, 1/4-lb. roll24
- E6297—Combination, 1/4-lb. roll29
- E6298—Tube Stock, 1/4-lb. roll24

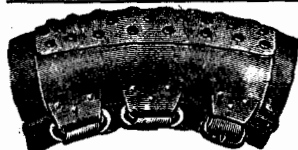

Strap-On Boot

The handiest and quickest boot ever made. Can be used on either front or rear tire on a Ford car, has strong leather straps and

buckles. Made of extra heavy strong grain leather with metal stud in center reinforced. The most durable and serviceable boot ever made. You should carry one in your tool box at all times. Shipping weight, 1 lb.

- E6404—For any 3 or 3 1/2-inch Tire. 68



Vulcanizing Cement

This high-grade cement is second to none. A first-class cement for use as any vulcanizer.

Our Reduced Price

- E6337—1/4 Pt. Can.
- E6338—1/2 Pt. Can, shipping weight, 8 oz.

K. C. No-Stretch Boot

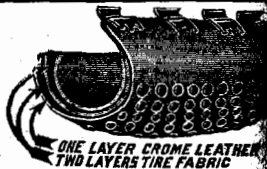

Guaranteed against stretching. Here is a boot that will wear well and stand the racket. Made entirely different from anything heretofore brought on the market, outside of boot is a special waterproof steel studded leather and inside, cemented thereto by special process, are layers of extra heavy rubberized stretch-proof tire fabric. Molded to exactly fit the tire, thus combining the features of both the rubber boot by being stretch-proof and the leather and steel for surface wear. Shipping weight:

- E6390—For 3" Tire.
- E6391—For 3 1/2" Fabric Tire.
- E6389—For 4" Fabric Tire or 3 1/2" Oversize Clincher.
- E6388—For 4" Straight Side Tires.

INTER-LOCK INNER TIRES

Double Your Tire Mileage

The Inter-Lock is a complete extra inside tire that is easily put on the regular casing and the inner tube. It is made exactly like a tire, full rounded, endless, and will not crawl, heat or chafe. It does not interfere with inner tube, speed or resiliency. Takes the strain completely from the side and rim of tire, as well as the tread.

The fabric construction is the backbone of a tire. The difference between a good tire and a poor one is mainly in the fabric used in its construction. Inter-lock Inner Casings practically double the strength of your tires and they will practically double the service as well, reducing the usual tire troubles to the minimum.

The Inter-lock is different from all other liners made. Notice the extension of fabric, or flap, which laps over the tube, making an enclosed self-sustaining inner casing.

Comes ready for use; easy to install. Made of best quality tire strength fabric (4 and 5-ply, according to size), carefully vulcanized with genuine rubber tread, to protect against punctures and break the tire walls. Will fit all style tires. Interlocks are no expense. We have handled them for years and consider them the best liners for inner casing made. Satisfactory service guaranteed or your money back. Try a pair and you will want a full set.

Inter-lock Casings are not an extra expense, as they pay for themselves many times over. They can be used from one tire to another. One Inter-lock Inner Casing will often outwear several tires.

Why wait until your tires begin to give you trouble? Put in Inter-lock Inner Casings now and save your tires, get full mileage and prevent trouble. Remember, "One ounce of prevention is worth a pound of cure."

For oversize cord tires use next larger size of INTER-LOCK

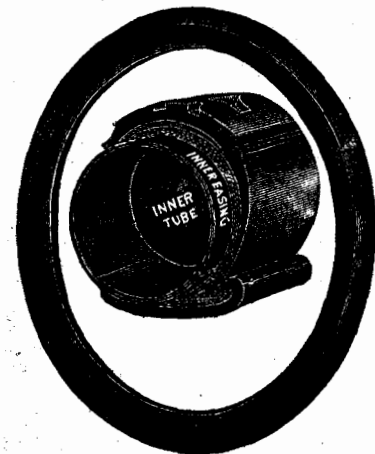

No.	Size	Price Each	No.	Size	Price Each
W8312	30x3	3.15	W8316	31x4	4.45
W8313	30x3 1/2	3.45	W8317	32x4	4.45
W8315	32x3 1/2	3.65	W8318	33x4	4.45
			W8319	34x4	4.45

Prices on other sizes on request. 30x3 and 30x3 1/2 sizes carried in stock. Other sizes shipped from warehouse or factory.

Tire Reliners



You may think because your tires look good on the outside and are not very old that they are good for lots of service, but factory records show that nine out of ten tires break inside and blow out before the tread wears out. This is because the fabric is not strong enough. The reliner is made to overcome this trouble. Our Champion Reliner is made of three and four plies, strong fabric rubberized and vulcanized together. When this is cemented inside the casing it gives the tire almost double strength, prevents blow-outs, helps to stop punctures and makes the tire hold up without trouble until it wears down almost to the reliner. Then you can remove the reliner and use it again in another casing, which makes the cost per tire very small. Our reliners will save their cost in preventing punctures, again in preventing blow-outs and again in extra mileage received from your tire, besides having the reliner left to use again. So you see you get your money's worth three or four times in buying reliners.

Champion Reliners are well worth the price we ask, but you get a great deal more for your money if you buy the Heavy Weight Reliner, as it is made of much heavier and stronger material, and will give more than twice as much service as the regular weight.

CHAMPION RELINERS

Number	Size	Ship Wt.	Price Each
E6417	30x3	3 lbs.	1.28
E6418	30x3½	3 lbs.	1.48

HEAVY WEIGHT RELINERS

Number	Size	Ship Wt.	Price Each
E6430	30x3	4 lbs.	1.78
E6431	30x3½	4 lbs.	1.95
E6432	32x3½	4½ lbs.	2.10
E6433	31x4	5 lbs.	2.70
E6434	32x4	5 lbs.	2.80
E6435	33x4	5 lbs.	2.90
E6436	34x4	5½ lbs.	2.95

E6439—Our Special Reliner Cement, 4-os. can, enough for one reliner **.14**

Sure-Hold Blow-Out Patch

When buying a blow-out patch it does not pay to get a small cheap one. If you are buying it to carry for emergency you should have one which will hold a large blowout or cut. Even if you want it to cover only a small hole or weak place in a tire, it is money saved to put in a long heavy patch which will prevent the tire from spreading and make it last nearly as long as though no hole was there, while a short patch in the same place would allow the hole to enlarge and patch bulge out in a short time.

Our Sure-Hold Patch is made of extra quality white tire fabric, six layers, with feather edge rubber tipped ends to prevent pinching tube. Has very heavy strong flaps which look over both beads and will hold a bad rim cut as well as a large blow-out.

Better carry one or two of these in your tool box. Average shipping weight, 8 os.

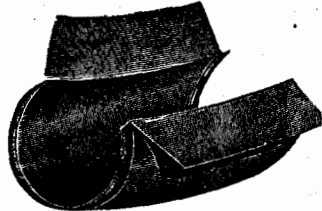

E6360—Extra Long for 3" Tire	.34
E6361—Extra Long for 3½" Tire	.48
E6362—Extra Long for 4" Tire	.65
E6363—Extra Long for 4½" Tire	.85
E6364—Extra Long for 5" Tire	.65

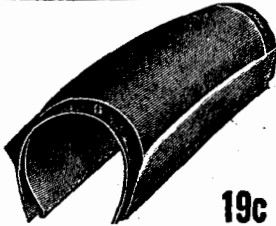

Double-Lock Blow-Out Patch

A strong and durable inside patch that will hold any ordinary blow out or rim cut. Locks over both beads so it cannot creep. Rubber tipped ends to prevent pinching tube.

19c

This is a good patch for the money, but for hard service we recommend the Sure-Hold shown above as it is better material, will last longer and hold a larger break or blow-out. Average ship. wt., 8 os.

E6366—For 3 -inch Tire.....	.19
E6370—For 3½ -inch Tire.....	.23
E6371—For 4 -inch Tire.....	.29

Sta-Put Blow-Out Shoe



straight side casing as well as a clincher. Easy to put on. First lace slack, then draw up to size. Fits cord or fabric tires equally well. Shipping weight, 1½ lbs.

E6405—For 3 - inch tires (length 10 inches).....	.39
E6406—For 3½ -inch tires (length 12 inches).....	.48
E6407—For 4 - inch tires (length 14 inches).....	.58
E6408—For 4½ inch tires (length 16 inches).....	.68

Made from the best grade of casing fabric, extra long to meet all requirements. Will hold a blow-out or rim cut on a rim cut or a

Tire Plaster Patch



Here is a quick, easy, efficient way of repairing punctures and small blow-outs in your casings, without the expense and delay of vulcanizing them. Has three layers of tire fabric with an upper layer of soft rubber gum.

Simply place a plaster over the hole to be stopped, replace the tube, inflate your tire, and drive off. The pressure forces the soft rubber gum up into the hole and closes it entirely, thereby keeping out sand and gravel, while the fabric layers vulcanize themselves to the tire, making it stronger than before. Made in three convenient sizes. Average ship. wt., 8 os.

Size	Our Reduced Price
E6365—For small nail holes, etc. each.....	.12
E6366—For large nail holes and small cuts, each..	.16
E6367—For large cuts, each.....	.20
X8819—Assortment, one each of above sizes....	.75

Mica Powder and Tire Talc

It is necessary to use something of this kind in casing to prevent tubes from sticking. It also prevents excessive heat on tubes. The soapstone answers the purpose under ordinary conditions, but we recommend the Mica Powder, as it will not cake, harden or absorb moisture like soapstone or talc. Put up in cans with sifter top. Average shipping weight, 1 lb.

E6359—Mica Powder.....	.14
E6358—Tire Talc (Soapstone).....	.10



EVER-LASTICK RUBBER BACK PATCH

Carry a Can With You For Emergencies

A quick, permanent repair patch for inner tubes. Cut your own patches to fit the repair to be made, any shape, large or small; buff tube thoroughly with special metal buffer furnished with each outfit, then apply sufficient cement, allowing it to dry 5 minutes. Cut proper size of patch, rounding the corners large enough to allow about 1/4 of an inch around hole, then apply the patch by pressing center directly over the injury, then pressing it out smoothly toward the edges. Outfit comprises roll of rubber patch, special metal buffer and tube of rubber cement, with full instructions. Screw top cans.

Ever-lastick is equal, if not superior, in quality, to any high-priced advertised patch selling for from 75c to \$1.00. The rubber is of the highest quality and the cement could not be made any better regardless of cost. Ever-lastick Patch Outfit should not be confused with low quality patches made of reclaimed rubber offered by some houses at slightly less prices. Ours is a strictly guaranteed patch made for the man who wants the best. Put a can in your car now and be ready for an emergency.



Our Reduced Price

- E6312—Small, 30 sq. in. (shipping weight, 8 oz.)..... **.29**
- E6313—Large, 72 sq. in. (shipping weight, 1 lb.)..... **.59**

Monkey Grip Tube Patch

The well-known Monkey-Grip Tube Patch, scientifically made of best pure gum rubber. Convenient and easy to use—no tools or heat necessary—quickly applied, will stick instantly, giving an instant repair almost as strong as if it had been vulcanized. Furnished in convenient sizes. Full and complete directions and buffer with every can.



wt., 8 oz.)..... **.34**

E6319—Outfit contains 45 square inches of patch, tube of cement and buffer (ship. wt., 1 lb.)..... **.54**

Shure-Hold Fabric Back Patch

This is a sheet of extra quality rubber, raw gum on one side and the other side semi-cured and a sheet of heavy khaki canvas vulcanized to it. It will repair any size puncture or long split in tubes or make small repairs in casings without tools or heat. It is quickly applied and will instantly almost as tight as vulcanizing. Tube of cement is furnished. Excellent outfit to carry for emergencies. Full directions furnished.



E6306—Small, 30 sq. in. (shipping weight, 8 oz.)... **.34**
 E6307—Large, 72 sq. in. (shipping weight, 1 lb.)..... **.54**

Rubber Roughener



A very handy brush to clean or roughen inner tube before patching, or parts to be vulcanized. Made of wood with hundreds of fine steel bristles. Very durable and inexpensive. Shipping weight, 8 oz.
 E6349—Each..... **.13**

Patching Cement

A high-grade cold patch cement use with any make of regular cold patch rubber.



Our Reduced Price

- E6342—1/4" Tube, wt., 2 oz..... **.13**
- E6343—1/2 Pt. Can, wt., 8 oz..... **.26**

"Quick-Repair" Rim-cut Hooks

Rim-cut tires can be permanently repaired in a few minutes

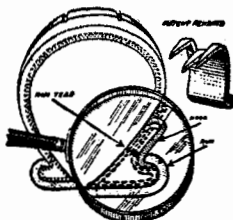

At last we have a practical remedy for rim-cut clincher tires. It hooks into the rim and the claws clinch into the tire above the break. When placed about one inch apart will make a permanent repair. All further wear from the rim comes on the metal hooks instead of on the tire. The Rim-Cut Hook is also the best preventative of rim

trouble. If you find a tire just starting to rim-cut, put a few hooks in place and save future trouble from blow-outs. After clinching the claws or prongs into the tire it is well to cement a strip of fabric or rubber over the points to prevent the tube from being injured. Our "Sure-Hold Fabric-Back Patch," shown above, is good for this purpose.

Every motorist should carry a few of these hooks in his tool box and be ready for an emergency. Shipping weight, per dozen, 8 oz.

E6356—Per dozen... **.39** —Per 100... **2.95**

Tire Iron and Rim Wrench

THE TOOL OF A THOUSAND USES



A handy tool for prying tires on and off. Also has hexagon holes 3/8" and 1/2", which fit most popular rim nuts. Length about 14". Ship. wt., 1 lb.

H7522—Our Reduced Price, each..... **.49**

"Perfect Handle" Tire Iron

Extra Strong—Easy on Hands



A high quality tool for taking off and putting on Drop-forged and accurately tempered. Has wood handle which allows firm grip. Nicely finished. Length, 11 inches; shipping weight, 1 lb.

H7521—Our Reduced Price, each..... **.49**

TIRE CUT-FILLER

A HEAVY RUBBER PUTTY COMPOUND THAT FILLS CUTS AND HOLES

36c

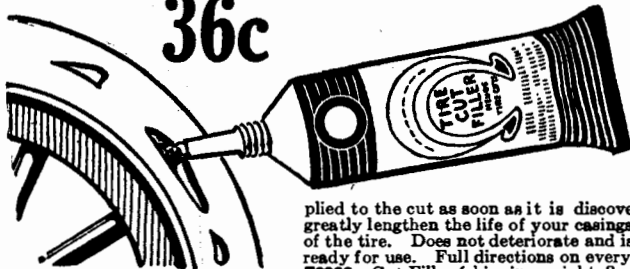

Tire Cut Filler is a heavy rubber putty compound that fills cuts and holes in casings. The smallest out in an auto casing will soon become a large sand blister, unless sealed immediately. Sand blisters permit water to reach the canvas fabric, causing the thread to work loose and rot, making a blow-out certain. A small amount of Tire Cut Filler applied to the cut as soon as it is discovered, will prevent blow-outs and greatly lengthen the life of your casings. It sets quickly, becomes a part of the tire. Does not deteriorate and is put up in a handy tube always ready for use. Full directions on every tube. **Our Reduced Price**
E6328—Cut Filler (shipping weight, 8 oz.)..... .36

Markoni Duplex Tire Carrier

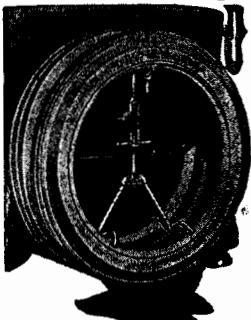

Lets you carry a second spare tire and, eliminating chafing or rattling. Automatically self-adjusted; quickly applied or removed without the use of tools.

Universal in size, fits any rim. May be quickly transferred from one car to another. Furnished with a padlock which can be inserted in hole provided, to lock both tires and carrier against theft. Tire covers may be used on both tires. Made of high grade material. Light in weight, but very strong and rigid. Also makes a good tool for spreading demountable rims in mounting tires, or to contract rim when removing them. Fits any car. Carry an extra spare on your car, and be prepared for emergencies. Shipping weight 6 pounds.

A5192—Duplex Tire Carrier, with padlock..... 3.95

"Universal" Side Tire Carrier For Ford

Fits Any Ford Roadster or Touring Car 1915-1924

Will carry one or two tires with or without demountable rim. Easily installed—no holes to drill. Fastens rigidly at top to bolts that hold windshield bracket. Bottom part fastens to bolts in running board.

Nicely finished in black enamel. Shipping weight, 3 lbs. **J7804—Each, complete .98**

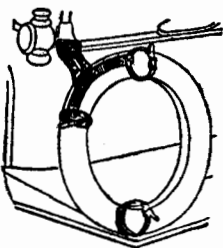

Michelin Mastic Outfit

Here is the famous Michelin Mastic and Cement outfit for repairing cuts and holes in casings. When the tread rubber on a tire is cut or torn, water, sand and dust work into the opening and soon cause the fabric to deteriorate. By the use of Michelin Mastic this may be prevented. Simply clean the hole well with gasoline, apply the cement, and as soon as it becomes "tacky" press the Mastic into the hole. Full detailed instructions on every can. This outfit may add several hundred miles to the mileage of your tires. Shipping weight, 8 oz.



E6323—Complete outfit..... .44

Tire Flaps

Extra Quality

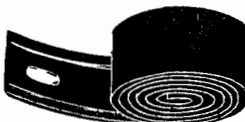

Should be used in every tire. Prevents the tube from rubbing on the rough rim and permits it to lay against the smooth surface of the flap. Made of several layers of good fabric with edges beveled. Will save their cost on every tube. Shipping weight, 1 1/2 lbs.

- E6541—Fits 30x3 1/2, 31x4, 32x4 1/2, 33x5 tires, each .49**
- E6542—Fits 30x3, 31x3 1/2, 32x4, 33x4 1/2 tires, each .49**
- E6543—Fits 32x3 1/2, 33x4, 34x4 1/2, 35x5 tires, each .49**
- E6544—Fits 34x4, 35x4 1/2, 36x5 tires, each .49**

No-Rust Tube Protector

A very practical device for protecting inner tubes from being worn out by rusty rims. It is a zinc strip which lies flat on the rim and clamps at valve stem.

Quickly and easily applied. Will not slip, chafe or rust, and will outlast your car. Makes your tubes last twice as long. Furnished for clincher tires only. Shipping weight, 1 lb.



Our Reduced Price

- E6410—For 30x3 wheels, each .48**
- E6411—For 30x3 1/2 wheels, each .48**

Tucker Spoke Shims

When your wheels get loose in the spokes, just put in some of these little shims around the dowel of the spoke next to the felloe. This takes up the shrinkage and makes your wheel as good as new. Can be driven in without using the special jack and drift shown, but they are essential for a first-class job.

K8005—Shim only, for Ford, Chevrolet, Overland, Maxwell, and other light cars, dozen (8-oz.)..... .18

K8006—Shim only, for Buick, Oldsmobile, Dodge, (wood felloe) dozen..... .20

K8007—Shim only, for Dodge (steel felloe), Essex, Studebaker, Ford ton truck, dozen..... .22

K8008—Ball-bearing spoke jack (ship. wt., 3 lb.)..... 2.69

K8009—Setting drift (ship. wt., 8 oz.)..... .19

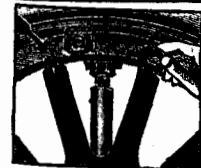

Rubber Mallets

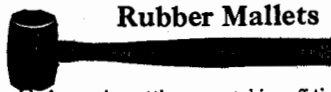

High quality rubber mallets for general use around the car. Especially valuable

for use in putting on or taking off tires. Noiseless and cannot injure articles hit with it. Head made of medium hard rubber of best quality. **Our Reduced Price**
A5232—Length across face 2", ship wt. 1 lb.45
A5230—Length across face 2 1/2", ship. wt. 1 1/2 lb.78

Genuine Schrader Valve Cores

A flat tire is often caused by a leaky valve core. A box of these insides in your tool box will enable you to dispense with the trouble quickly. Valves are packed 5 in a tin box with sliding lid—they can't lose out. Shipping weight 4 ounces.



J7700—Per box of 5..... .24

New Improved Valve Cores



This improved style of valve core provides a more thoroughly leak-proof and more efficient tire valve than has ever been produced. Any one who has experienced difficulty in the proper insertion or removal of a valve inside will see by looking at the illustration that this is entirely eliminated, because all the parts are fully enclosed. There are no loose springs to get out of order and all material is of the best possible selection and is subjected to the closest inspection. Fits perfectly in any valve stem and is interchangeable with other types of valve cores. Can be used with any pump or standard pressure gauge. To install, simply remove old valve inside and screw new one down as far as it will go. Packed in containers holding 5 valve insides. Shipping weight, per box, 4 oz.

J7722—Package of 5 insides..... .24

Valve Caps and Washers



J7690

J7696



J7694

J7695

J7690—Valve Caps (Box of 5) .24

J7695—Dust Cap, about 2 3/8" 5c

J7694—Valve Bushing Nut with flange, ea. 5c

J7696—Valve Bushing Nut plain, each... 5c

Leak-Proof Valve Caps

Absolutely prevent valve leaks and the resulting under-inflation that ruins thousands of tires. Screws down inside valve stem, thus blocking passage of air, besides forming a guide for upper end of valve plunger, insuring a perfect seat. Satisfaction guaranteed or money refunded.



Our Reduced Price

J7705—Set of 5 (shipping weight, 8 oz.)..... .26

Tire Valve Tool

This valve tool will thread inside and outside of valve stem; also has key for removing inside core and die for smoothing off end of valve stem. Its shape makes this the handiest of all valve tools to use. Should be in every tool box. Shipping weight, 2 oz.



Our Reduced Price

J7714—4-in-1 Tool, each..... .15

Screw-On Pump Connection

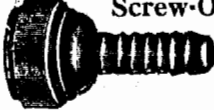

Pump connection threaded inside to fit all Schrader valve stems. Well made and will outlast the pump. Shipping weight, 4 oz.

J7716—Each..... .12

Thumb Lock Pump Connection

To use Thumb Lock, simply push the connection down over the valve stem and press down on the lever. This fastens securely and will hold under great pressure. To release, lift up on lever and connection comes off easily. A great time saver. Should be on every pump. Rubber will last indefinitely. Shipping weight, 4 oz.



J7666—Each..... .20

Genuine "Schrader" Tire Gauge

95c



Constructed on a new and improved principle, and has no equal for accuracy, convenience, and general appearance. Can be carried in the vest pocket, being only 2 inches long, always ready for use. When pressed on the valve stem it registers the pressure in the tire accurately. After removing the gauge from the valve the indicator remains set at the pressure in tire. This retaining feature is a great convenience, enabling you to use gauges in dark, as well as in the light. To reset the gauge for next reading, push indicator down into place. No leather case furnished with each gauge. Shipping weight, 8 oz. Regular list price, \$1.35

J7707—Schrader Tire Gauge and Case..... 95c

Schrader Special Tire Gauge
For Trucks and Wire Wheels



The "Goose" feature gives close to valve in close place. Shows pressure from 30 to 120.

Neat leather case.

J7708—Each, (Ship. wt., 8 oz.)..... 1

Genuine Schrader Tire Gauge
FOR BALLOON TIRES



Accurately indicates tire pressures by single pounds from 10 to 42 lbs. An absolute necessity for every balloon-tire user who wishes to get the best service from his tires.

J7710—Each (shipping weight, 8 oz.)..... 1

Pressurite Tire Gauge



A well-made, accurate tire gauge easy to use and easy to read. Simply apply to valve stem in usual position. Remains stationary unless released by hand, letting you read gauge and read it readily in any position. Guaranteed accurate and reliable. Shipping weight, 8 oz.

J7702—For wood wheels, shows pressures up to 120 lbs.....

J7703—For balloon tires, shows pressures up to 40 lbs.....

Acorn Pump Connection

This connection slips over the valve stem; rubber washer grips and holds it secure. Fits any valve; is air tight. Washer will last for months.



J7660—Pump Connection, (Ship. wt., 4 oz.).....

J7661—Rubber Washer Only.....

GENUINE ROSE TIRE PUMPS

An indestructible steel barrel single action pump which works easier than any other pump made, and will last a lifetime.

Motorists have now learned that the most satisfactory pump is a large size, well-made, foot-proof, single-action pump.

The Rose Pump has a patented valve which takes air through the plunger and eliminates friction; can not get out of order, and will last indefinitely. It pumps much easier than an ordinary pump. Will work as well in five years as the day it is purchased. The barrel is made of heavy 18-gauge steel tubing, heavy enough that it will not dent by rough handling. Has folding base, so the pump will take up very little space in a tool box.

Made in two sizes, 1 1/4" barrel regular, and 1 3/4" barrel extra large, which is a very fast and powerful pump.

Length over all, 21 3/4 inches, so it will fit in any standard tool box. You can pay more money, but you can't get a more serviceable pump than the ROSE. "Satisfaction or Your Money Back."

E6504—Regular 1 1/4" Size, shipping weight, 4 lbs. 1.90
E6506—Extra Large 1 3/4" Size, shipping weight, 5 lbs. 2.28
E6507—Screw Connection at base of pump (will fit all Rose and most standard pumps), shipping weight, 2 oz.12



STANDARD TIRE PUMPS

Equipped with Standard Size Rubber Hose and Universal Valve Connections

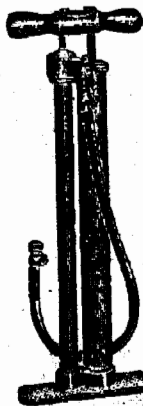

2-Cylinder Pump

A well-made pump of two cylinder design. Cylinders are made throughout of seamless steel tubing. Finished in black enamel. Cylinders are 17 inches long, large barrel 1 3/4 inches in diameter and small one 1/2 inch. Shipping weight, 5 lbs.

Our Reduced Price
E6522—2-Cylinder pump . . . 1.19



1-Cylinder Pump

A low-priced pump with 1 1/4 inch seamless barrel. 17 1/2 inches long. Has folding base and special clamp-on hose connection, as illustrated. Well-made, well-finished, easy-working. An unusual value. Shipping wt. 4 lbs.

E6521—1 Cylinder pump
Our Reduced Price85



Western Big Chief Pump

A one-cylinder pump considerably larger than E6521, with 1 3/4 in. barrel, 21 in. long. Will pump up a tire much quicker. Has heavy steel barrel, with brass plated rust-proof fittings on handle.

Equipped with slip-on hose connection. Well made; fully guaranteed. Ship. wt. 5 lbs.
E6515 Our Reduced Price 1.48



Pump Washers

High grade leather washers for 1, 2 and 3 cylinder pumps.
J7681—1/4 inch 2c
J7683—1 1/4 inch 3c
J7684—1 3/4 inch 4c
J7685—1 1/2 inch 4c
J7686—1/2 inch 4c
J7687—Washer for 1 1/4-inch Rose Pump 6c
J7688—For 1 3/4-inch Rose Pump 7c

J7686—1/2 inch 4c
J7687—Washer for 1 1/4-inch Rose Pump 6c
J7688—For 1 3/4-inch Rose Pump 7c

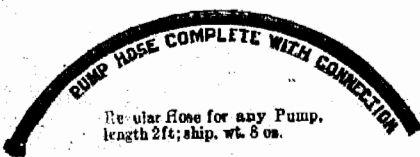

Regular hose for any Pump, length 2ft; ship. wt. 8 oz.

E6505—Complete with connection that screws on valve . . .24
E6507—Screw connection at base of pump (not included with hose in E6505) for most standard pumps12



Hose Clamps

For tire pump hose lines. Made of soft brass.

Price Each 1/2 Doz.
J7697—1/2" 3c14
J7698—3/4" 3c15
J7699—1" 4c16

Adjustable License Plate Frame



Dress up your state license plates with these adjustable aluminum frames. Made of pure aluminum, highly polished; rust-proof, weather-proof; good year after year. Expands both

ways, so that it will fit any size plate, and you can use it for years, even if license plates vary in size and shape from year to year. Attached by anyone in a moment's time—all you need is a screwdriver. Furnished with brass screws for attaching. Shipping weight, 12 oz.
E6564—Adjustable License Frame, each78

Pump Tubing

Extra heavy, extra quality rubber tubing for hand and power pumps. Tubing made especially for heavy pressure. Shipping weight, 1 lb. to 5 feet. Our Reduced Price, per Foot.
E6526—3-10' Hole, 3 ply 8c
E6527—1/2" Hole, 5 pl.10



GENUINE WEED DE LUXE CHAINS REDUCED PRICES



Improved Lever-Locking Connecting Hook

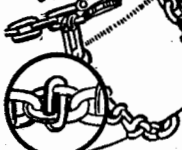

New Reinforcing Link Feature

\$3.75



For the man who prefers Weed chains, we offer this latest improved type, with reinforced crosslinks and lever-type connecting hook. but for general all-around use, country or city, we recommend our "Western Giant" chains as

not only better value for the money, but a more serviceable chain.

Aver. ship. wt. of Weed chains, 3½", 17 lbs.; 4", 18 lbs.; 4½", 21 lbs.; 5", 27 lbs.

X8960... 30x3½	3.75	X8966... 32x4½	5.30
X8961... 32x3½	4.12	X8967... 33x4½	5.45
X8962... 31x4	4.50	X8968... 34x4½	5.65
X8763... 32x4	4.55	X8969... 35x4½	5.95
X8964... 33x4	4.90	X8971... 33x5	6.40
X8965... 34x4	5.25	X8972... 35x5	6.75

Same Size Chains Fit Both Oversize Cord and Fabric Tires.

WESTERN GIANT TIRE CHAIN

\$2.70



As Good as Money Can Buy

Made especially for us by one of the largest chain manufacturers in the country, Western Giant chains are unquestionably the best chain value we have ever offered. Heavy, case-hardened cross-links, brass-plated to prevent rust, insure long service and best gripping action on slippery roads. A new improved ener holds chain securely, while making it easy to put or take off. Sold under our guarantee of Satisfaction or Money Back.

Aver. ship. wt., 3½", 15 lbs.; 4", 18 lbs.; 4½", 20 lbs.; 5", 27 lbs.

X8800... 30x3½	2.70	X8806... 32x4½	3.75
X8801... 32x3½	3.10	X8807... 33x4½	3.85
X8802... 31x4	3.35	X8808... 34x4½	4.15
X8803... 32x4	3.40	X8809... 35x4½	4.45
X8804... 33x4	3.55	X8810... 35x5	4.75
X8805... 34x4	3.85	X8811... 35x5	4.75

Same Size Chains Fit Both Oversize Cord and Fabric Tires.

Emergency Tire and Mud Chain



Made of best grade, hardened steel. Easily and quickly put on when you need them. Place the malleable clamp on the spoke, then slip the chain over the tire and hook the snap in the loop. No jack or tools required. If necessary to shorten chain simply open steel link and adjust to proper size. One chain on each rear wheel will pull you out of almost any hole. Ship. wt., 3 lbs. each.

K8023—For 3 and 3½-inch tires, each.....	.78
K8024—For 4 and 4½-inch tires, each.....	.85

FOR FORD TON TRUCK

K8032—For use with 3½" solid tires, each.....	1.85
K8033—For 4" or 4½" pneumatic tires, each....	1.05



"Klinch-Link"

Used to replace broken or worn side links in tire chains. Slip into place and clinch quickly with hammer or pliers. Carry a few in your tool box and be ready for emergency. Ship. wt., 1 oz. D6172—Each 3c, 6 for 16c, 12 for 30c.

Non-Skid

Cross Chains



Case-hardened. Fit any standard chains. Wt., 6 oz.

Plain as shown	Each	DeLuxe type	Each
D6161—3½-in.....	.6c	D6174—3½-in.....	.8c
D6162—4-in.....	.7c	D6175—4-in.....	.9c
D6163—4½ in.....	.8c	D6176—4½-in.....	1.0c
D6164—5-in.....	.9c	D6177—5-in.....	1.1c

Non-Skid Chain Repair Tool



For opening and closing the hooks of cross chains. Lets you replace broken cross links without deflating tire or removing chain from the wheel. Also has an effective wire cutter. Drop-forged, tempered and accurately machined. Length 9½ inches.

D6166—Each (shipping weight, 1½ lbs.).....	.49
--	-----

No-Nox Chain Fasteners

Saves Your Tires and Prevents Loss of Chains.

A simple and efficient device that gives even tension to the chain. Allows the chain to float freely around the tire, thereby eliminating main cause of tire bruises and gouging. Will not catch or tear off. Prevents chains from striking body and fenders. Will save their cost many times over every season. Made of strong, oil tempered steel wire, baked black enamel finish. Shipping weight, 1 lb. D6183—For 30x3 and 30x3½ tires, Ford size, per pair..... .65 D6184—For 32x3½ to 34x4 tires, per pair..... .75



Steel Chain and Tire Tool

A heavy tool made of high-grade steel for putting on and tightening tire chains. Loose chains are a constant annoyance and may tear off a fender. With this tool you can easily tighten your chains in a minute. Also makes an excellent tire iron, as it is heavy enough to pry an ordinary tire on or off a rim. D6228—Each (Ship wt., 2 lbs.)..... .40



Carson's Tire Chain Fastener

Easy to put on and take off; cannot come loose; no prying in mud or snow to unfasten; takes up all the slack and makes chain run silently. Also insures best traction, lengthens the life of chains and tires, and makes it impossible to lose chain. A necessity for every car owner. Ship. wt., 8 oz. D6179—Set of 4, with 4 extension links for lengthening chains for use on cord tires.....



Front and Rear Wheels for Fords

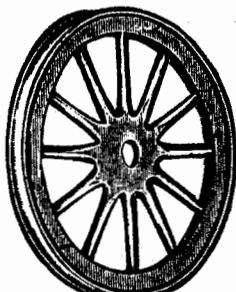

Carefully made of best second growth hickory. Strong steels rim. Finished black. Varnished. Replaces regular wheels for all models Ford cars.

Have all four wheels the same size, so that the extra tires carried can be used on any wheel.

Front hubs fit in rear wheels, as flanges and bolts are the same. Shipping weight of wheels, each, about 17 lbs.

W8409—30x3 1/2, Regular Clincher, each. **2.95**
W8410—30x3, ea. **2.95**

W8401—Demountable wheel without rim or hub; will fit any rim used as standard equipment on Ford cars, also fits Chevrolet 490, Star, and Overland 4; size 30x3 1/2, black finish, each. **2.95**
P2825—Wheel Bolt and Nut, Shipping wt. 2 oz. **3c**

SPOKE-TITE

FOR LOOSE, SQUEAKING WHEELS

Spoke-tite is a preparation that expands wood. It is not a glue. Easy to apply with the hand from hand nozzle sprout can. Just squirt Spoke-tite into the cracks. Examine your wheels today; jack up your car; spin wheels and listen for rattle. Examine the joints of hub and felloes. If you have even one loose spoke, don't delay or take chances. Spoke-tite is inexpensive. Can also be used on carriages, wagons, floors, etc. Will not injure paint or varnish. Ship. wt., 6 oz. **G6942—Our Reduced Price per can . 65**



Rim Lug Wedges

Stop Squeaking of Demountable Rims



Adjusted in one minute to one, two or three thicknesses as may be required to stop the squeaking of the rim and keep the wheel true. Will conform to all kinds and sizes of rim lugs. Goes on the bolt with lug and cannot lose off. Time and money saved with Three Wedges in One. Shipping weight, 1 oz.

B5297—Each **4c** Set of 6. **.18**

Zim Rear Wheel Retainer

A safety device that should be on every Ford car. Prevents the rear wheel from coming off in event the axle shaft breaks, thus preventing damage to car or passengers. Also enables the car to be towed home on its own wheels for repairs. Fastens to brake shoe bolt; easily installed by anyone; only a wrench needed. Will last as long as your car.

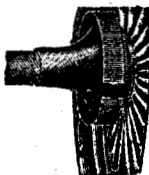

H7410—Per pair (ship. wt., 12 oz.) **.45**

Genuine Weed Chains

For Ford Ton Truck



Weed Truck Chains are the same as Weed Regular in principle, but are made much heavier and stronger to stand the hard wear on heavy trucks. Make the most efficient traction and anti-skid device for truck use. Price shown is for pair complete for both rear wheels of Ford One Ton Truck.

D6156—32x3 1/2 Weed Chains for Ford Ton Truck with solid tires, (Ship. wt., 28 lbs.) per pair. **5.78**
D6157—32x4 1/2 Weed Chains for Ford Ton Truck with pneumatic tires, (Ship. wt., 30 lbs.) per pair. **6.85**
D6181—Extra Cross Links for D6156, each, (Ship. wt. 8 oz.) **1.4**
D6182—Extra Cross Links for D6157, each, (Ship. wt. 8 oz.) **1.2**

Rim Parts for Ford, Maxwell, Chevrolet 490 & Dodge Cars



High quality replacement rim parts for Ford, Maxwell, Chevrolet 490 and Dodge cars. Guaranteed to fit. If your rims are loose and squeaky you had better put on new lugs before the bands are too badly worn. Average shipping weight each, 2 oz.

J7910—Lug for Ford. **.12**
J7912—Lug for Ford. **.12**
J7911—Lug for Ford. **.12**
J7913—Nut for Ford, using rim with lugs attached. **.12**
J7914—Nut for Ford used with J7911. **.12**
J7936—Spare Rim Carrier Clamp for Ford. **.14**
J7914—Lug for Maxwell and Chevrolet 490. **8c**
J7915—Bolt for Maxwell and Chevrolet 490. **8c**
J7916—Nut for Maxwell and Chevrolet 490. **8c**
J7937—Lug for late 1921 and later Dodge with 32x4 or 33x4 1/2 tires. **.11**
J7938—Bolt for late 1921 and later Dodge with 32x4 or 33x4 1/2 tires. **.10**
J7935—Nut for late 1921 and later Dodge with 32x4 or 33x4 1/2 tires. **5c**
W8399—Dem. rim, Hayes, with lugs attached, 30x3 1/2 clincher, for Ford, Star, Overland 1923 and Chevrolet 490 open cars, 1922-23 (ship. wt., 12 lbs.) **1.40**
W8387—Dem. rim, Hayes, with lugs attached, 30x3 1/2 straight side, for 1922 Chevrolet 490 closed cars and all Chevrolet Superior closed cars (ship. wt., 12 lbs.) **2.35**

High Quality Rim Wrenches



This is a high-grade rim wrench made of heavy steel with knob that turns so that no matter how fast you turn the wrench you cannot blister your hands. Socket sizes are accurate and

made to fit. Easy and quick action. Ship. wt., 2 lbs.
J7880—3/4-in. opening (Ford size) **.48**
J7881—1-in. opening **.48**
J7882—1 1/4-in. opening **.48**

Hub and Axle Shim

FOR FORD REAR AXLES

Used to rebuild worn axleshafts and wheel hubs. Saves cost of new hub or axle. Prevents hub bolt nuts from striking brake shoe bolt. Ship. wt., 8 oz.



K8046—Our Reduced Price, each **8c**

Hub Caps for Fords

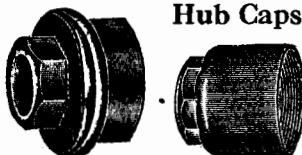

Well made of best material. Guaranteed to fit and give excellent service. Furnished in nickel or aluminum. Shipping weight each, 4 oz.

A5150—Regular Cap nickel-plated, each. **.10**
A5144—Fancy aluminum, each 12. Set of 4. **.45**

Wheels and Rims for Ford Ton Truck

Set consists of two wheels with felloe bands, rim bolts and lugs, three 32x4 1/2 straight side demountable rims, twelve hub bolts, one rim wrench. Best-grade second growth hickory spokes. Finished in black. Shipping weight, 118 lbs. per set. **24.50**
Our Reduced Price, set **7.65**
X8574—Wheel only, no rim, wooden felloe (22 lbs.). **3.65**
X8580—Rim only for truck wheel, wood felloe (19 lbs.). **3.65**
K8223—Hub bolt and nut for truck, each **7c**

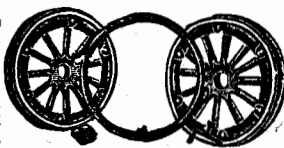

Tilting—Locking Steering Wheel

Combines Driver's Convenience with Utmost Protection Against Theft

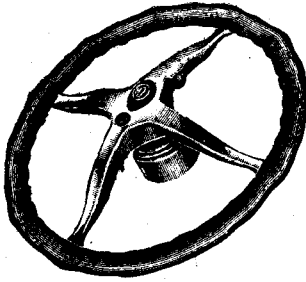

A handsome oversize steering wheel (17-inch) with polished aluminum spokes which incorporates a high-grade spinning lock and a convenient tilting mechanism. Anyone who has had to squeeze and squirm and wriggle under a steering wheel will appreciate the advantages of this tilting feature. Simple, positive, and easy to operate; will outlast your car.

The lock is constructed of case-hardened steel throughout, handsomely mounted and equipped with an improved Yale lock and two keys. When locked, the steering mechanism is cut out, so that the wheel spins freely and car cannot be driven away. Fully approved by Underwriters' Laboratories. Will reduce your theft insurance 15 per cent.

Wheel is equipped with a black enamel horn button in center. Each wheel shipped completely assembled, and can be installed by anyone in five minutes as easily as attaching any steering wheel. Adds to appearance of any car. Complete with keys and instructions. Shipping weight, 8 lbs.

- A5036—For any model Ford car 9.
- A5037—For Chevrolet 490 or Superior 9.

Simplex Lock for Ford Cars

Approved by the National Underwriters Laboratories.

By installing this lock on your car you can get a big reduction in your insurance rate, that will soon pay for the lock, not to mention the security of protecting your car against thieves. Replaces the top cap of the gear housing which is directly under the steering wheel. When car is locked, the front wheels are held securely in any one of four positions, preventing car from being steered or towed.

Conveniently located; can be locked instantly. A lock you cannot forget to use, because the key cannot be removed until lock is in locked position. Made of case-hardened, drop-forged steel with nickel finish. Equipped with Yale cylinder lock and two keys. Easily installed in ten minutes by anyone without changing the original construction of the car. Full instructions furnished. Simple, safe, positive, neat in appearance; guaranteed for the life of the car.

The Simplex Lock works perfectly with the regular Ford steering wheel, no change being necessary, but by purchasing also the big 17-inch steering wheel with aluminum spider and corrugated walnut finish rim shown on page 35, a complete oversize locking-wheel outfit can be had at a very low price.

- A5038—Lock only, with keys and instructions. (Ship. wt., 2 lbs.) 3.35
- A5131—Wheel only (shipping weight, 5 lbs.) 1.95
- X8617—Lock and 17" Wheel complete. (Ship. wt., 7 lbs.) 5.25

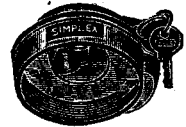

Lock Only
\$3.35



\$5.25
Complete

Locking Door Handles

For Ford Sedans and Coupes

Protect your car and contents from theft. Leave your robes, wraps or other articles in your car with the assurance that they will be there when you return. Made to slip right into the place of the regular handles. No filing or fitting necessary.

After handles are in place and working properly, small aluminum caps forced down over screw heads, which cannot be removed without drilling. Slightly larger than the regular handles, making it easier to open door. Handsome nickel-plated and highly polished, adding greatly to the appearance of the car.

Two styles—A5027 has lock in right handle only, the left handle being stationary, always locked from the outside but never from the inside. A5028 has two locking handles, using the same keys. Each set includes the two handles, two keys, screws, caps and instructions. Easily installed by anyone in a few minutes. Ship. wt. pair, 2 lbs.

- A5027—Set, one plain and one locking handle, complete 1.35
- A5028—Set, two locking handles, complete 2.35



Set Complete
\$1.85

Yale Vigilant

This is a strong, secure burglar resisting lock. It embodies all the worthy features of the Yale products and will give splendid service. Being a flat, thin type lock gives it a neat appearance. Is highly finished in ivory black. Two keys with each lock. Furnished in two sizes, 1½-inch and 2-inch. Wt., ¼ lb.

- A5000—1½", price each29
- A5001—2", price each39



Genuine Yale Padlocks

Heavy Black Steel

This lock is an extra heavy steel lock made with a 3-lever tumbler same as in the more expensive locks. Is burglar-proof and will withstand rough service. The brand Yale is a guarantee of highest quality. Is furnished in two sizes. Each lock has two keys. Shipping weight, ½ pound.

- A5005—1½", price each 1.38
- A5006—2" (Fits Ford tire carriers), price each 1.58



Yale "Titan" Lock

A practical and inexpensive lock, burglar resisting, strong and secure, neat in appearance. The brand Yale is a guarantee of quality.

This is a well-made lock, three ward mechanism, with heavy brass-plated steel shackle. Black case with brass plated panels. Complete with 2 keys. Ship. wt. 8 oz.

- A5010—1½ inch lock, each 49



Yale Padlock No. 52

A heavy, substantial 1½" padlock at a popular price. Will stand up to usage. Furnished complete with keys. Sells regularly at about \$2.00.

Our Reduced

- A5016—1½", each 1.50



TIRE COVERS

HIGHEST QUALITY—LOWEST PRICES

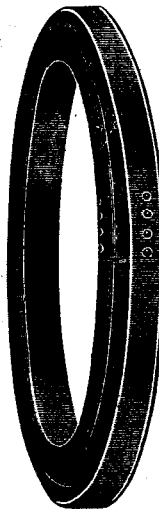

Protect your spare tires from the sun, rain and dampness. Light will deteriorate rubber tires almost as much as regular wear. You have probably carried a spare tire on your car for a long period and then put it on and found that it did not give you the proper service. This was doubtless due to the fact that sun, heat and rain had really "killed" the rubber. Nothing adds more to the appearance of spare tires than neat, well-fitting covers. These beaded tire covers are made of black imitation patent leather with a beautiful gloss finish and have two stripes of white piping running around the seams, as shown in the picture. This gives them a very attractive finish and makes them very popular covers. Soft and durable. Easy to put on or take off. All covers extend to the rim only, as the rim itself keeps the water out. Made for either fabric or cord tires in the following sizes. Ship. wt. about 3 lbs.

For Fabric Tires

F6771—30x3½ for dem. rim.	1.60
F6772—32x3	1.70
F6773—31x4	1.70
F6774—32x4	1.75
F6775—33x4	1.95
F6776—34x4	2.00

For Oversize Cord Tires

F6780—30x3½, for demountable rims	1.60	F6786—32x4½	2.05
F6781—32x3½	1.70	F6787—33x4½	2.10
F6782—31x4	1.70	F6788—34x4½	2.15
F6783—32x4	1.75	F6789—33x5	2.20
F6784—33x4	1.95	F6790—35x5	2.25
F6785—34x4	2.00		

Straps and Strap Loops



High quality straps with buckles for strapping on extra tires, trunks, tents, etc. Ship. wt., 12 oz.

J7852—Strong web strap, 1" x 36 in.	65
K8117—Strong web strap, 1½" x 7 feet.	65
K8118—Strong web strap, 1½" x 9 feet.	65



Black harness leather strap with buckles.

J7853—Leather strap, 1x42 in. long, 1 in. wide.	39
J7854—Leather strap, 1x36 in. long, 1 in. wide.	35
F6701—Strap Loop, 1½ in., black enamel finish (2 oz.)	4c

Lock and Chain

A strong chain, 36 in. long, covered with imitation leather, with substantial lock, for locking spare tires, or can be placed around front wheel and steering knuckle to prevent car from being moved or stolen. Shipping weight, 2 lbs.



Our Reduced Price

X8683—Chain and Lock complete .72
A5042—Chain, only .42

Universal Tire Carrier Lock

Adapted for use on all cars. The only lock that will fit the late model Ford tire carrier, also fits the Buick, Overland, Oakland and Chevrolet. Made of heavy cast brass, polished; has ¼-inch nickel steel shackle, adjustable in length. Comes equipped with two keys. Is burglar-proof. Will not rattle. The brand "Slaymaker" is a guarantee of highest quality. Shipping wt., 8 oz.



A5026—Each .95

Fancy Nickel Plated Radiator Shell FOR FORD CARS

One of the newest and most popular ornaments for a Ford car. This is a high-grade shell of standard size and shape, made of 20-gauge cold-rolled steel, beautifully nickel-plated. Has seven upright bars made of aluminum with deep thread and highly polished. Greatly enhances the appearance of any car. Furnished for 1917 and later Fords only. Shipping weight 15 pounds.

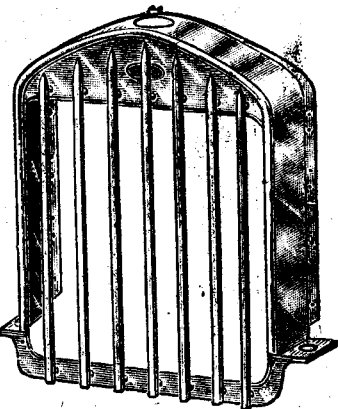

X8684—Rad. shell with bars, for 1917-1923 Ford 6.65
X8685—Rad. shell with bars, for 1924 Ford..... 7.35

Supreme Spare Tire Lock

Protects Your Tire from Theft



\$3.95

Why wait until your spare tire has been stolen before buying a lock? Safeguard it while you have it with a Supreme Tire Lock. A heavy ½" case-hardened steel chain with case-hardened point, neatly covered with genuine leather.

One of the most secure and substantial tire locks on the market, with genuine Yale bronze lock and two keys.

A5070—20" long (ship. wt., 2 lbs.)	3.95
A5071—25" long (ship. wt., 2½ lbs.)	4.15
A5072—33" long (ship. wt., 3½ lbs.)	5.15
A5073—37" long (ship. wt., 4 lbs.)	5.35

"Security" Tire Chain and Lock

A high-grade lock and chain for protecting your spare tire from theft. High grade steel chain, in substantial leather-oid sleeve that prevents chafing and rattling.



Strong, substantial lock with individual keys (two for each lock), so arranged that even breaking the lock will not release the chain. 36 inches long. Shipping weight, 3 lbs.

A5044—Our Reduced Price 1.68

Hercules Spare Tire Protector

A strong sturdy malleable casting, hinged so as to pass around the tire and lock both tire and rim to the tire carrier. Better than the ordinary tire chain because stronger and will not rattle. Quickly and easily installed. Will last as long as the car. Well finished in black enamel. Fits outside of tire cover. For Ford cars and others using standard 30x3½ clincher tire.

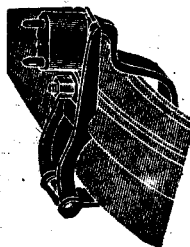

J7806—Protector complete (without lock) Ship. wt. 1 lb. .85
A5026—Lock for above.. .95

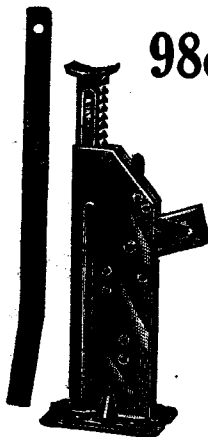

98c

All-Steel Jack

A light-weight jack that will stand heavy service. Made entirely of steel of the best quality. Simple construction and easy to operate. Easy to reverse by pulling trip lever up or down. Height 10 1/4 inches, lift 6 inches. For use on any car or truck weighing up to 2000 lbs. Furnished complete with long steel handle and finished in baked black enamel to prevent rust. Absolutely guaranteed. Shipping weight, 6 lbs.

J7828—Our Reduced Price..... **.98**

Junior Screw Jack

An inexpensive jack suitable for any light car weighing up to about 2000 lbs.; adjustment 10 to 17 inches, strong and durable, no parts to get loose; self-locking, quickly adjusted.

A good value. Shipping weight, 5 lbs.

J7821..... **.88**

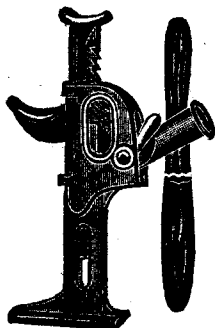
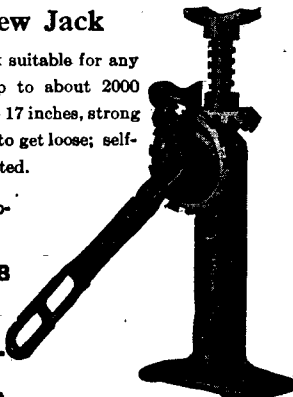

Atlas Giant Jack

A very strong, easy-working jack. Can be operated quickly. Suitable for any car or truck weighing up to 3000 lbs. Adjustment 8 to 15 inches. Made of high-grade malleable; very durable. Complete with strong wood handle.

Shipping weight, about 6 lbs.

Our Reduced Price

J7818—Giant Jack.. **1.18**

Robe Rails

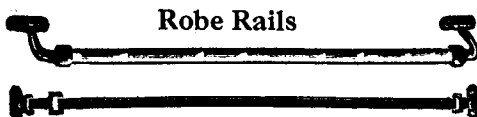

Very handy for wraps and coverings that otherwise would have to be held or crumpled up in a corner. Metal rods fold down when not in use.

A5136—Black enameled rod, 1/2" thick, 29" long with curved ends (not illustrated). Weight, 2 lbs..... **.42**

A5139—Strong 5/8" nickel-plated bar, with fancy black enamel end bracket, as shown in top illustration. 29 inches long, ship. weight, 3 lbs..... **.65**

A5141—Black genuine leather rail, with nickel-plated attachments. Snap at end makes it easier to put articles on or off. 28" long. Shipping weight, 1 lb..... **.60**

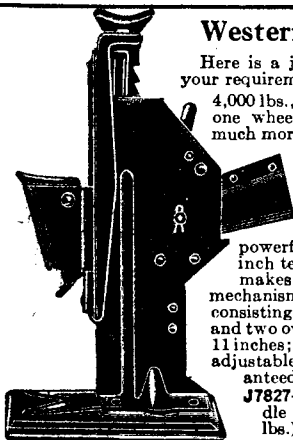

Western Giant Jack

Here is a jack that will meet all your requirements. Actual capacity 4,000 lbs., which means it will lift one wheel on a load weighing much more. Made of best heavy-gauge steel, with extra long cup base which will not bend or allow car to roll off jack. The short handle-stroke and powerful leverage of its 36-inch telescoping metal handle makes easy lifting, while the mechanism is the simplest in use, consisting of but one heavy spring and two over-sized pawls. Height 11 inches; lift 5 to 17 inches, with adjustable side-step. Fully guaranteed.

J7827—Complete with handle (shipping weight, 12 lbs.)..... **2.95**

Heavy Duty Truck Jack

Small, but mighty—will lift 6,000 lbs. Very simple in construction, quick and easy to operate. Extensible handle—no loose parts to get lost. Self-locking at any point. Screw is toughest cold-rolled steel, 1 inch in diameter. Height, 10 1/4 inches; lift 6 inches. Standard equipment on many trucks.

No need to take chances of overloading a weaker jack when you can get the "Heavy Duty" at our low price. Ship. wt., 10 lbs.

J7819—Each .. **..... 2.55**

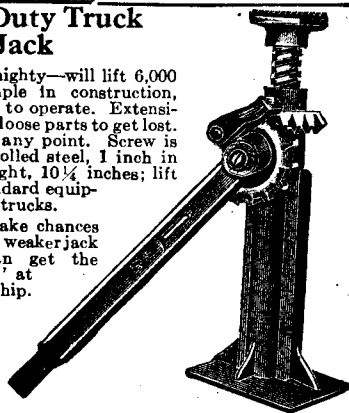

NON-KICK DEVICE

FOR FORD CARS

A positive crank release, which works automatically. The instant the motor backfires and starts backward the "Non-Kick" device forces the crank out, so it is released from the ratchet. It is positively guaranteed against defects or breakage and to work perfectly at all times. It slips right on over the crank and can be attached by any one with only a wrench, in a few minutes. Does not interfere with cranking or spinning the motor. Shipping weight, 2 lbs.



Send us your order for a Non-Kick device today—try it out on your car for 10 days. Then if not satisfactory return it and we will refund your money.

A5187—For 1909-1920 Ford cars with two spring clips as shown in illustration..... **1.35**

A5189—For 1921-1923 Ford cars, with new style single spring clip. (Will not fit 1924 models.) **1.49**

Hercules Rim Tool MAKES TIRE CHANGING EASY

A labor-saving Tool that should be in the toolbox of every car with demountable rims. Will pay for itself the first time you have to change a rusty, stubborn rim. Absolutely indispensable for lady drivers. Very efficient in operation. Breaks, shrinks and expands all makes and sizes of split automobile rims without tool being removed from the rim. Automatically locks rim in shrunken position so that it can be removed from tire or replaced inside tire with ease.

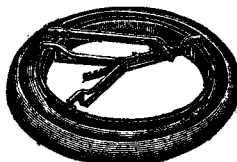

Our Reduced Price A5025—Rim Tool, complete (ship. wt., 10 lbs.) **3.35**

Williams' Accelerator for Ford Cars

One of the highest grade accelerators made. Has an improved spring action, which is entirely independent of the hand throttle, allowing it to be operated just as easily as before attaching the accelerator. Very simple construction. No adjustments to make, no springs to connect to frame, no levers or ball and socket joints that are usually required to produce a high-grade accelerator system. Complete instructions on every box. Shipping wt., 2 lbs. Regular list price, \$3.00.

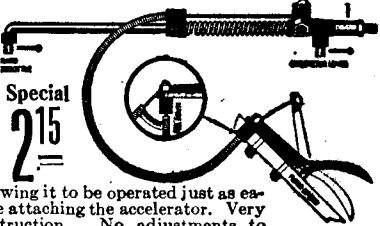

Special
215

D6005—Our Reduced Price, complete. **2.15**
D6006—Extra wire for above. **.25**

Williams Junior Accelerator

Very similar to accelerator shown above, except that it clamps on the regular carburetor pull rod instead of replacing it. Simple and easy to install. Well made and durable. Ship. wt., 1 1/2 lbs. **D6056**—Complete with instructions, **1.28**

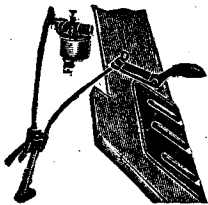

Accelerator Heel Rest

Prevents foot from slipping and causing uneven flow of gas. Also prevents the heel from wearing a hole in the floor mat. Made of aluminum, highly polished. Will not rust or tarnish. Extra large size, to fit any heel.

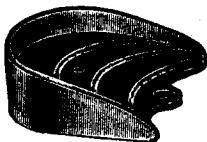

D6004—Each (wt., 4 oz.) . **28**

Adjustable Foot Rest

There are so many cars and so many drivers that this is the only type of Foot Rest that will fit any of them equally well. This type is easily applied to any car and can be set at any height by simply turning the adjusting nuts. Finished in dull nickel. Provides relief from the driving strain of long trips. Shipping weight, 21 lbs. **D6016**—Each. **.29**

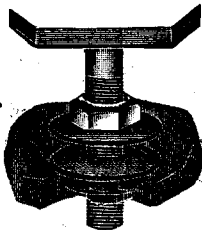

Handy Foot Rest

Enables you to feed steadily even on rough roads. Has black enameled metal base with pyramid rubber rest which fits in the arch of your shoe, prevents slipping of foot and "plunging" of throttle.

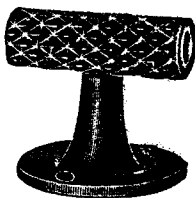

D6013—Each, (Wt., 1 lb.) **32**

Heel Plates

Every car owner knows how rapidly the floor mats and carpets are worn out around the foot pedals and accelerator. Unless new mats are put in frequently, danger may result from catching the heel in one of these holes. Our heel rests absolutely prevent this wear on the mat and also make a very neat and attractive appearance. Can be put on any car in a few minutes.

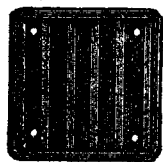

F6737—Rubber heel plate, 4x4 ins. (Ship. wt., 8 oz.) **.17**

Genuine "Bull-Dog" Accelerator

This is the genuine "Bull-Dog" foot accelerator, almost too well-known to require an introduction. With the new improved rubber-covered pedal, mat binder and non-slip foot rest it is better than ever before. Works independent of the hand throttle. Easily put on. Fully guaranteed. Shipping weight 2 lbs.

Rubber on Pedal
Mat Binder
Foot Rest

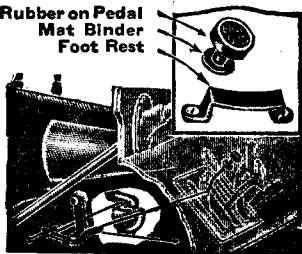

D6011—Each, complete with instructions. **1.35**

Speed-Way Foot Accelerator for Ford Cars

This foot accelerator is intended to combine the good points of all others. It is simple in operation, durable and nicely finished. Can be put on easily by anyone. Its action is easy and positive. The pressure of the foot goes direct by a rod to the lever which pulls the carburetor rod, making it sensitive and accurate. It works independent of the hand throttle. A foot rest is included in the outfit and full instructions furnished. Shipping weight, 2 lbs. Regular Price, \$1.50.

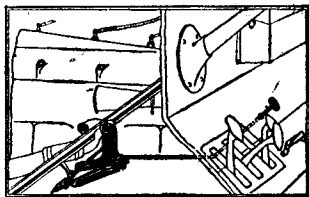

D6000—Each, complete with Foot Rest. **.95**

Our Reduced Price

Bull-Dog Rubber Accelerator Pedals

FOR POPULAR CARS



Resilient live rubber pedals for replacement on foot accelerators of Chevrolet, Maxwell, Overland, Star, Oldsmobile, and other cars, as well as Bull-Dog Accelerators for Ford. Simply screws on rod where other pedals screws off. Won't slip, won't wear shoe; more comfortable for foot.

Our Reduced Price

D6017—Each (ship. wt., 8 oz.) **.22**

Universal Accelerator Foot Rest

FOR ALL CARS

A foot rest that enables you to drive for long periods without foot strain. Lets the foot come down solidly and remain there without effort on the driver's part. Also enables the driver to feed the gas evenly regardless of how rough the road is. Made of solid aluminum. Ship. wt., 3 lbs.

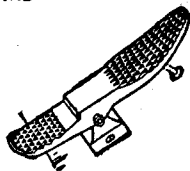

D6003—Our Reduced Price, each **.85**

Cigador

An unusually attractive match-cigarette, and ash-holder for the motorist's use. When cigarette receptacle is closed, lid lies flat, but when it is opened, the cigarettes are lifted up where they can be easily secured, as shown in illustration. Substantially made of best materials, heavily nickel plated.

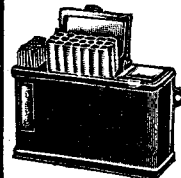

Shipping weight, 1 lb.
B5278—Standard Cigador, as illustrated **3.85**

B5279—Midget Cigador with receptacle for matches and ashes, but none for cigarettes (not illustrated) . . . **1.95**

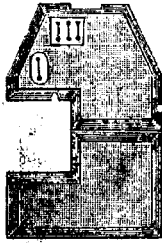

Weather-Tight Rubber Mats

FOR OPEN AND CLOSED FORD CARS

Extra quality, long-wearing rubber mats, guaranteed to fit.

Front mats are made to fit close around the pedals as shown in illustration, to keep out the cold draft in winter and the engine heat in summer. These are heavy, substantial mats and should not be confused with the light-weight open-type mats offered by some at slightly lower prices. Shipping weight, 5 lbs.; sedan, 10 lbs.

- F6750—For front of Touring or Roadster, 1915-23..... **.85**
- E6557—For front of Touring or Roadster, 1924..... **.95**
- E6551—For rear of Touring, 1915-23 (size 28x30 inches)..... **.78**
- E6558—For rear of Touring, 1924..... **.78**

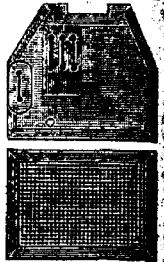

- E6553—For Ford 2-door Sedan, 1915-23 (complete, two pieces)..... **2.55**
- E6552—For Ford Coupe, 1916-23..... **1.15**
- E6559—For Ford Coupe, 1924..... **1.38**

- E6580—For front of 4-door Sedan, 1923-24..... **1.30**
- E6581—For rear of 4-door Sedan, 1923-24..... **1.30**
- E6582—For front of Tudor Sedan (Coach)..... **1.30**
- E6593—For rear of Tudor Sedan (Coach)..... **1.30**

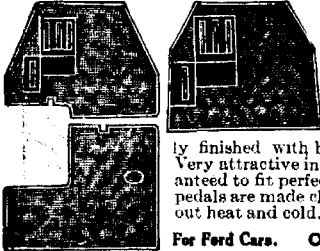

Carpets for Popular Cars

Made of good quality Auto Carpet material and neatly finished with binding all around. Very attractive in appearance. Guaranteed to fit perfectly. Openings for pedals are made close-fitting, to keep out heat and cold.

For Ford Cars. Our Reduced Price

- F6752—For Ford 2-door Sedan, (wt. 4½ lbs.)..... **3.95**
- F6751—For Ford Coupe, 1916-23, (wt. 3 lbs.)..... **3.50**
- F6753—Rear Tonneau, Ford Touring, (wt. 2½ lbs.)..... **1.85**
- F6754—Roadster or Front Touring, (wt. 3 lbs.)..... **1.85**
- F6739—For Ford Tudor Coach, complete (5 lbs.)..... **3.55**
- F6740—For front, Ford 4-door Sedan (3 lbs.)..... **1.50**
- F6745—For rear, Ford 4-door Sedan (2½ lbs.)..... **1.50**
- F6767—For Ford Coupe, 1924 (3 lbs.)..... **1.95**

For Any Other Make of Car

We can furnish these extra quality carpets for almost any make and model of car on special order at the following prices. Shipment on some styles made from our stores, others direct from factory. Allow 10 to 12 days for order to reach you. In ordering, state year and model of car.

- X8856—Sedan, complete, wt. 8 lbs..... **7.95**
- X8857—Coupe, wt. 5 lbs..... **5.65**
- X8858—Roadster or front of Touring, wt. 4 lbs..... **4.65**
- X8859—Rear tonneau of Touring, wt. 5 lbs..... **3.45**

In ordering be sure to state year and model of car

Clamp-on Rubber Pedal Pads

For Popular Cars.

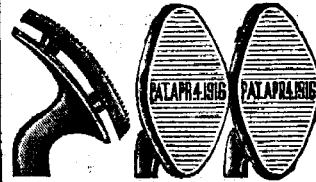

Prevent feet slipping at critical moments. Absorb jars and vibration felt by the feet from engine. Also help the appearance, as they are very neat. Made of soft durable rubber.

Attached to pedals by binding metal clamps around pedals. Will not slip or come off. Extra heavy and serviceable. Ship. wt., set, 1 lb.

- F6730—For all model Ford cars, set of 3..... **3.4**
- F6731—Clamp-on pedal pad, fits Buick, Chandler, Chevrolet, 1924; Cleveland, Dodge 1924, Durant 6-cyl., Duesenberg, Elcar 4-cyl., Jordan, Kissel, Lincoln, Oakland, Oldsmobile, Overland, Packard, Saxon 1920-22, Star, Stutz 1920-22, White and Wills-St. Claire (not illustrated), per pair..... **.78**

Slip-on Rubber Pedal Pads

A lighter weight pedal pad that slips over pedals and is held by an extension on edge. We advise using a little cement when putting on these pads. Standard quality rubber; well made. Ship. wt., 1 lb.

- F6734—Set of 3..... **.29**

Western One-Piece Metal Foot Board

FOR FORD TOURING, ROADSTER AND COUPE

Well made of strong automobile steel, correctly designed, black enamel finish. Replaces present wood boards on Ford roadster, touring and 1915-23 coupe; will not fit sedan or 1924 coupe. Very easy to install, no holes to drill. Fits snugly into place and positively will not rattle or slip. Prevents accidents that frequently happen when wood boards break and jams pedals.

- F6747—Each (shipping weight, 6 lbs.)..... **1.65**



No-Slip Pedal Extensions

For Ford Cars

Do you find the pedals on your car too small for easy and comfortable use? No-Slip Pedal Extensions practically double the

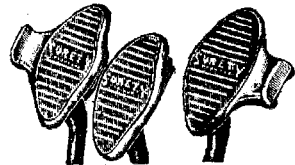

width of pedals: they are made of special alloy of metals giving both strength and lightness. Easily and quickly attached to any Ford car. No holes to drill; just slip them over pedals and tighten special clamps with screwdriver. Set consists of pads with extensions for clutch and brake, and plain pad to match for reverse pedal.

- F6733—Per set (shipping weight, 2 lbs.)..... **.78**

Cocoa Fibre Mat and Rug



A very serviceable foot-cleaner for running-boards of any car. Well made, closely woven and substantially bound. Two special spring clamps (woven in) hold it securely without bolts or screws. Instantly put on or taken off. A great convenience. Not only gives positive foothold when getting on car, but serves to keep car clean and free from dirt and mud. Size, 8x14 in. Ship. wt., 3 lbs.

- F6744—Cocoa Mat for running board..... **.69**
- F6745—Cocoa Rug for rear tonneau of 1915-24 Ford Touring Cars. Size 19x30 in. Not illustrated. Ship. wt., 8 lbs..... **2.48**

Super Quality Floor Boards

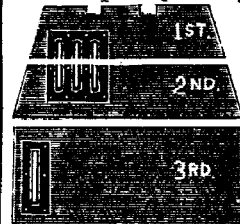

Don't try to get along with split or damaged floor boards. They may slip and hold up your brake pedal some time, causing you a serious accident. The average floor boards for Ford, are made of cheap lumber that breaks easily. For that reason we are now offering our Super Quality Floor Boards. They are made of three-ply best quality hardwood material and will last as long as the car. Exact fit for Ford Touring, Roadster and Coupe, but must be sawed slightly to fit Sedan. Attractively finished. Furnished complete with metal floor board plates. Cost a little more, but cheapest in the long run.

Our Reduced Price

- F6755—Front or First Floor Board. Wt. 4 lbs..... **.48**
- F6756—Middle or Second Floor Board. Wt. 4 lbs..... **.48**
- F6757—Rear or Third Floor Board. Wt. 4 lbs..... **.69**

as long as the car. Exact fit for Ford Touring, Roadster and Coupe, but must be sawed slightly to fit Sedan. Attractively finished. Furnished complete with metal floor board plates. Cost a little more, but cheapest in the long run.

Interchangeable Fenders

FOR FORD CARS **\$10.85**

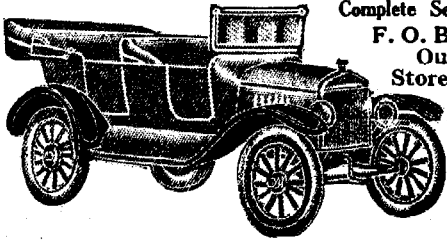

Complete Set
F. O. B.
Our
Stores

Our fenders are made of the best 20-gauge automobile steel, cold drawn, finished glossy black baked enamel. Strongly reinforced at all points of strain. Strictly high quality at a big saving in price. Carefully crated.

Furnished for Touring or Roadster, Coupe and Sedan Ford Cars. Same style and design as regular Ford Fenders and interchangeable with them. Our prices offer a worthwhile saving.

Furnished in regular 56-inch tread only. Shipping weight, 90 lbs. Shipped from stock.

X8517—For all model Ford cars from 1917 to 1923, except 4-door sedan—Complete Set **10.85**

For single fenders see page 98

These fenders can be used on 1916 or older Fords by replacing running board shields with new style (our No. X8541)

X8541—Running Board Shields, 1917-23, pair. **3.85**
For Running Boards see page 102

Comb. Bumper and Fender Braces

FOR 1917-24 FORD CARS

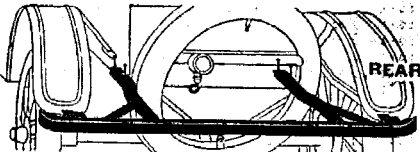
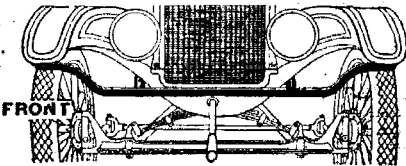

Rigidly brace the fenders, preventing rattling and breaking. Also serve as bumpers to protect car, as well as fenders, from damage.

Strong, substantial, good-looking. Well finished in black enamel. Easily installed by anyone in a few minutes' time. Don't wait till your fenders are loose or damaged, but put on these braces and be safe. Ship. wt., 18 lbs.

Cannot be sent by mail.
X8860—For rear of 4-door Sedan or Tudor Coach **3.35**
X8861—For rear of any other model Ford. **3.65**
X8863—For front of any model Ford 1917-24. **3.65**

"Sturdy" Front Fender Brace

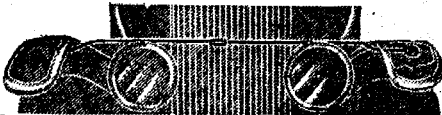

One of the neatest front fender braces on the market. Fastens on the fender eye-bolts as shown in illustration—doesn't mar top of fender or slip back and rattle against radiator. Clears radiator and lamps an inch.

Made of special bolt stock Bessemer Steel, with heavy turnbuckle and machine cut threads. Turnbuckle secured by two lock nuts. Finished in baked black enamel. Easily put on in a few minutes' time; full instructions furnished.
W8380—Each, complete (ship. wt., 21 lbs.) **7.85**

Aluminum Step Plates

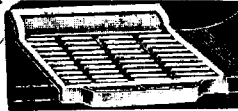

A5237

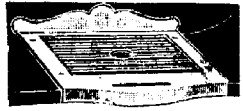

A5239

Protect the finish on your running boards and running board shields with our aluminum step plates. Made of beautifully polished aluminum and have upturned flange, which prevents the foot from striking the running board shield. Corrugated to prevent slipping and are very useful for scraping mud and dirt off the shoes, thereby allowing you to keep the interior of your car clean. A5237 and A5238 are solid aluminum. A5239 is a heavy aluminum frame, 9"x12" over all, with a high-grade rubber mat, 7 1/4"x11 1/2", inserted in center, and makes a very fine combination for use on any car. A5237 and A5239 will fit any car, A5171 is special for Fords. Shipping weight, 2 lbs. Price Each
A5237—Plate as illustrated, with scraper, 10 1/2"x9 in. **.98**
A5239—Rubber and aluminum plate complete size over all 9x12 inches **1.10**

A5171—Rubber and aluminum plate, about 7x9 inches, specially corrugated to fit Ford running board. **89**

Step Plates and Kick Plates

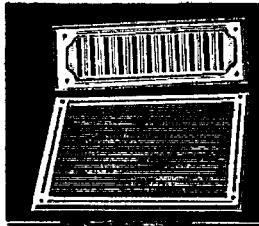

Glossy, jet black rubber mats with highly finished stamped aluminum frames. Add greatly to appearance of car as well as protecting running boards and shields. Ship. wt., 1 lb. Price Each
A5211—Flat step plate, 8x10 in. **.98**
A5212—Flat step plate, 10x12 in. **1.35**
A5209—Kick plate 4x10 in. **.58**

Rubber Running-Board Mat

A fine quality rubber mat; is very practical and presents good appearance. Removes moisture, mud and dirt from the soles of your shoes, also prevents slipping in stepping in or out of the car. Strong and durable, yet neat in appearance. Size: 11 1/2 in. long by 7 1/2 in. wide. Weight, 1 lb. F6738—Our Reduced Price **.19**



Adjustable Fender Brace

FOR FRONT OR REAR OF FORD CARS

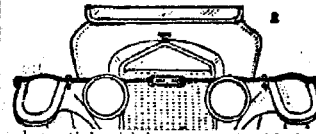

Keeps fenders from sagging, breaking loose or rattling. Impossible for fender to tip down and injure casing. Easily installed, no holes to drill. Strong and substantial, with heavy turnbuckle for adjustment. Black enamel finish. Shipping weight, 2 lbs.

W8369—Each, complete. **.49**

Front and Rear Fender Braces

FOR FORD CARS

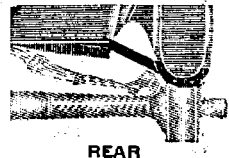
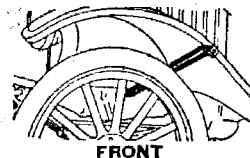

Made of strong steel, shaped in the proper way to hold fenders in place. Rear braces are bolted on fender and screwed under the corner of the body with heavy supports. Front braces are fastened under side frame and support the fender at the point most liable to break. Purchased complete with necessary bolts and screws for installing. If your fenders have not yet begun to sag, put on a set of these braces and prevent this trouble before your fenders are ruined. Weight per pair, 2 lbs.
D6194—Rear Fender Braces, complete, per pair. **3.85**
D6193—Front Fender Braces, complete, per pair. **5.85**

Seat Covers For All Cars

\$4³⁵
AND UP

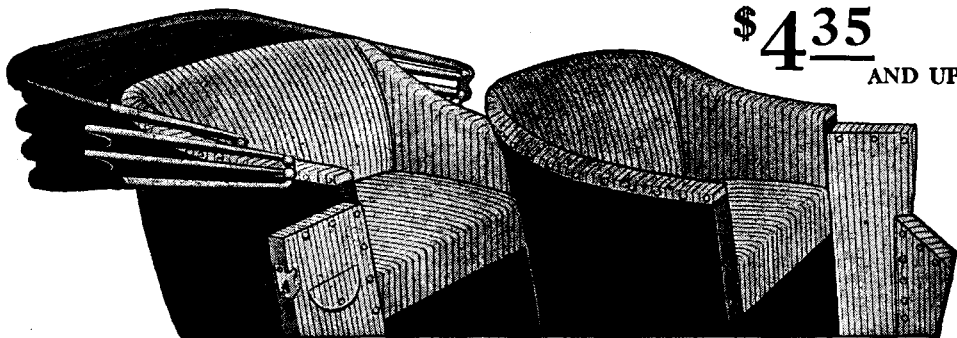

Seat Covers for All Open and Closed Ford Cars

There is nothing that will add so much to the general appearance of your car as neat, well-made seat covers. They make the car cooler in summer and warmer in winter. Protect your clothes and lengthen the life of the upholstery.

They give the car a fresh, clean, luxurious appearance, and add greatly to your comfort and convenience. You can restore the appearance of cushions that have become worn by long service, while by putting them on a new car you can keep the upholstery fresh and new, and increase its re-sale value when you get ready to dispose of it.

Our Seat Covers are well made in every detail. The material is strong and serviceable, with edges double-reinforced and very strong. Color, a very practical medium dark gray, not easily soiled, with an attractive striped

design. When soiled, they are easily cleaned with soap and water, though dry cleaning with gasoline is better.

These covers are quickly and easily attached by anyone—no experience necessary. All necessary tacks, screws and fasteners are furnished. Seats, cushions and doors, in both open and closed models, are completely covered as shown in illustration.

Be sure to give year and model of your car when ordering.

F6615—For Ford Touring Car (ship. wt., 6 lbs.)	7.45
F6605—For Ford Roadster (ship. wt., 4 lbs.)	4.35
F6612—For Ford Coupe (ship. wt., 5 lbs.)	5.45
F6611—For Ford 2-Door Sedan (wt., 8 lbs.)	9.85
F6613—For Ford 4-Door Sedan (wt., 6 lbs.)	10.95
F6610—For Ford Tudor Sedan (coach) (6 lbs.)	10.95

Western Tailored Seat Covers for All Cars

MADE FOR THE MAN WHO WANTS THE BEST

An extra-quality seat cover made especially to order for us. Materials specially selected and manufactured exclusively to our order—a closely woven, durable fabric that has stood the test of years of service for seat cover use.

The color is a rich medium dark gray background with small pin stripes that will harmonize perfectly with the trimmings of any car, and meet the approval of the most discriminating car owner. Sample of material furnished on request.

The covers are custom tailored, and have every little touch of refinement that goes to make up a strictly high-grade seat cover. The backs are shaped carefully to fit the contour of the car, and cushions are covered complete like covers of highest-quality cars.

Covers are completely equipped with highest quality snap-type glove fasteners, nickel-plated on brass, so they will not tarnish. In many numbers, more than 140 of these glove fasteners have been used, insuring a perfectly snug fit, as well as easy removal for cleaning.

Easily attached by anyone. All necessary glove fasteners, screw eyes, etc., furnished with every set.

Be sure to give year and model of car when ordering.

FOR FORD CARS

F6644—For Ford Touring Car (ship. wt., 6 lbs.)	9.45
F6645—For Ford Roadster (ship. wt., 4 lbs.)	5.45
F6646—For Ford Coupe (ship. wt., 5 lbs.)	6.45
F6647—For Ford 2-Door Sedan (ship. wt., 6 lbs.)	11.55
F6648—For Ford 4-Door Sedan (ship. wt., 8 lbs.)	12.95
F6655—For Ford Tudor Sedan (coach) (6 lbs.)	12.65

FOR CHEVROLET SUPERIOR

F6690—For Roadster (ship. wt., 4 lbs.)	6.45
F6691—For Touring Car (ship. wt., 6 lbs.)	11.55
F6695—For 2 pass. Coupe (ship. wt., 5 lbs.)	11.55
F6695A—For 4 pass. Coupe (8 lbs.)	13.95
F6696—For Sedan (ship. wt., 8 lbs.)	13.95

We can furnish Western Tailored Seat Covers for any make of cars. Write for samples and prices.

"Comfy" Seat Cushion

A well-made, inexpensive seat cushion that can be used in many ways to make driving and camping and boating more comfortable. Sit on it, use it for a back rest, or for a pillow. Made of rubberized cloth, with high-grade filler. Very serviceable. Holds its shape well. Shipping weight 3 lbs.

B5491—Seat Cushion, 15x15 inches, each **.95**

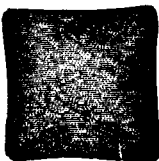

Driver's Back Cushions

Make Driving More Comfortable

This is a wedge-shaped cushion, made of heavy rubberized material, with long grain finish.

Cushion is stuffed with a high-grade downy material that gives excellent service.

Tufts are sewed in with black upholstery buttons, not only giving it a beautiful appearance, but preventing it from losing its shape. Excellent for women drivers or persons of small stature, making it easy to reach the brakes and clutch. Size about 14½x14½ inches. Average shipping weight, 5 lbs.



Burch Carrying Bag

For carrying articles such as clothing laundry when touring; also makes a emergency pillow, also a handy dry bag around the house. Made of heavy, khaki-colored duck, size 32"x18". Heavy cord draw-string and reinforced brass eyelets. Ship. wt., 2 lbs.

B5421—Our Reduced Price..... **.68**



B5490—Driver's Back Cushion.....	1.18
B5470—Extra Large Cushion, about 15x19...	1.78

Protect Clothes and Upholstery

Slip-on Seat Covers for Ford Cars

\$2.65 and up



Cover Cushions and Backs of Seats only

Slip-on Seat Covers are very popular, especially for summer use, because they furnish ample protection for the clothes and can be so easily removed for cleaning. Prevent clothes from sticking to cushion or back of seat in hot weather. Cooler and more comfortable; make car more attractive and inviting.

Covers are made of strong, serviceable, washable material of pleasing stripe pattern, not easily soiled. Easily laundered when necessary, and guaranteed fast colors. They fasten over special tack buttons, furnished with every set and can be slipped on or off by anyone in five minutes. Made of strong, high-quality material, shaped to seats. Please do not confuse these tailored, extra-quality covers with the cheap, flimsy, unshaped covers offered by some houses at slightly low-

er prices. Shipped direct from our stores. Average Shipping weight, 4 lbs. **Be sure to give year of car when ordering.**

F6616—Slip-on Covers, Ford Roadster . . .	2.65	F6614—Slip-on Covers, Ford 2-door Sedan (1918-23) . . .	5.95
F6617—Slip-on Covers, Ford Touring . . .	4.95	F6620—Slip-on Covers, Ford 4-door Sedan . . .	6.95
F6618—Slip-on Covers, Ford Coupe . . .	3.45	F6625—Slip-on Covers, Ford Tudor Sedan (coach) . . .	6.95

Cover Cushions and Backs of Seats only. Sample of material gladly furnished on request.

Slip-on Seat Covers for All Cars

COOL, CLEAN, SANITARY; MAKE CAR MORE ATTRACTIVE

The most practical seat covers made for an automobile; very popular everywhere. Can be used on any car. Can be slipped on or off by anyone in five minutes. Made of a durable, washable material of a neat, pleasing stripe pattern. These covers are easily laundered. Give your car that comfortable, bright and inviting appearance; protect upholstery and your clothing. Makes your car much cooler in summer, as well as warmer in winter. Covers come complete with nickeled glove fasteners. Easily detached for cleaning.



For all Touring, Roadsters, Sedans, or Coupes. Cover cushions and backs of seats only. Seven-passenger covers do not include covers for extra seats.

Sample of material furnished if desired. Covers are specially tailored to fit your car and shipped direct from factory. Allow 10 or 12 days for reaching you. Average shipping weight, 5 lbs. In ordering, give make, year and model of car, and whether you desire grade A, B, or C.

Cover Cushions and Backs of Seats only.

K8160—For all Touring models, Buick 4 cyl., Chevrolet, Maxwell, Overland 1920-24, Jewett, Nash 4 cyl. Dort, Durant 4 cyl., Star and Gray. For both front and rear seats and cushions.

K8161—For any Two-passenger Roadster of above makes

K8162—For any Four or Five-passenger closed car, above makes

K8163—For any Two passenger Coupe, above makes

K8164—For any Five or Seven Passenger Touring Car not shown above.

K8165—For any Two-passenger Roadster not shown above.

K8166—For any Five or Seven Passenger Sedan not shown above.

K8167—For any two or three passenger Coupe not shown above.

	"A"	"B"	"C"
	Regular Grade	Special Motor Fabric	Extra Qual. Motor Fabric
K8160	6.35	8.45	9.90
K8161	3.35	4.35	5.15
K8162	7.35	9.45	10.85
K8163	5.85	7.65	8.35
K8164	8.35	9.95	11.95
K8165	4.35	5.35	6.15
K8166	8.90	11.15	12.65
K8167	6.45	8.45	9.35



Seat Cover Material

For the convenience of the car owner who desires to make up his own seat covers, we are prepared to furnish cover material of good quality in pleasing striped design, that will not soil easily. Washable, guaranteed fast colors. We recommend it for wear. Width, 27 inches. Sold only by lineal yard. Sample on request. Shipping weight, 1 lb. **Our Reduced Price**

F6600—Light background, tan stripes, per yard. **.48**

F6601—Dark gray background, blue stripes, per yard. **.60**

For Upholstery Tape and Tacks, see page 29.

Top Recovers For All Cars

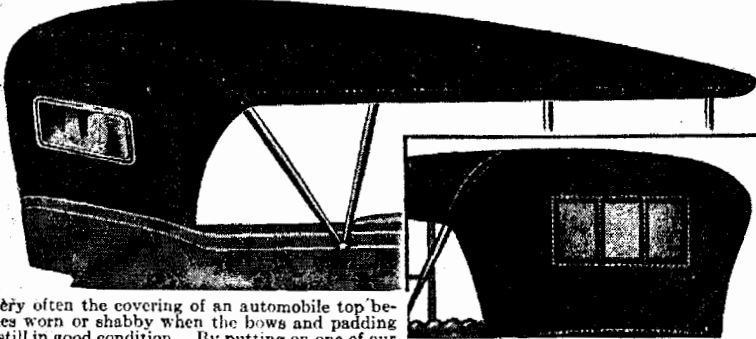

\$8.85

And Up

Be sure to give make, year and model of car, when ordering.

Very often the covering of an automobile top becomes worn or shabby when the bows and padding are still in good condition. By putting on one of our Leatheroid top recovering outfits you can make your top as good as new. They are properly cut and guaranteed to fit and can be put on by anyone. Simply remove tacks from front and rear of your old top cover and back curtain, slip old cover off and slip new one in its place. Comes complete with back curtain and sufficient upholstery tape and tacks for installing. Back curtain furnished with either three celluloid lights as shown in illustration at right or one 6x18 oblong bevel plate glass (shown above at left). Extra quality, heavy long-grain Leatheroid, with drab back, same as furnished on most high-priced cars, and should not be confused with the ordinary cheap rubberized material which some houses offer at slightly lower prices.

Recovers for Chevrolet, Dodge, Maxwell and Overland carried in stock, others shipped direct from factory. Average shipping weight, 17 lbs.

Gypsy style back curtains with any top for \$1.95 extra.

Car and Model	No.	Celluloid Lights	No.	One 6x18 Bev. Glass
Chevrolet 490 Touring	8622	1 1.6	8653	1 2.6
Dodge, Touring	8624	1 1.6	8654	1 2.6
Maxwell, Touring	8625	1 1.6	8655	1 2.6
Overland 4, Touring	8626	1 1.6	8656	1 2.6
Any Roadster	3632	1 8.8	8657	1 0.8
Any 5-Passenger not shown	8633	1 8.8	8658	1 3.9
Any 7-Passenger car	8634	1 2.9	8659	1 4.9

- X8635—Drab Top Pads for any Roadster, per pair..... 2.95
- X8636—Drab Top Pads for any 5-pass. Touring, pair... 3.95
- X8637—Drab Top Pads for any 7-pass. Touring, pair. 4.35

We can furnish back curtains only without top cover. Prices on request.

CHEVROLET SPECIAL

A fortunate contract enables us to make the following offer: X8618—Touring Car top recover, complete with gypsy style back curtain, for Chevrolet 499 best quality 34 oz. leatheroid, glass rear curtain light, size 6" x 18" (Ship. wt., 16 lbs.) State year of car. X8619—Same as X8618, for Chevrolet Superior Touring..... 8.65

\$8.65

ONE MAN TOPS FOR FORDS

With New Door Opening Side Curtains.

\$28⁶⁵

F.O.B. OUR STORES With Regular Side Curtains.

\$24³⁵

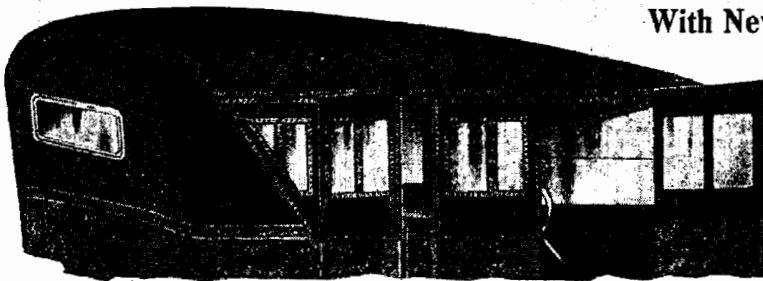

If your top is badly worn, replace it with a "one-man top." It will improve the appearance and utility of your car and make it look like a new model. This top can be raised and lowered by one person; is also much more convenient than the old style top, as no bows are in the way of passengers in the front seat. Touring car top has only three bows, but stands firm and rigid, and folds down into a smaller space than old style tops. Made of best grade black, long grain, drab back leatheroid top covering, which is far superior to the ordinary rubberized top material.

Has the new Gypsy style back curtain as illustrated and can be furnished either with one 7x14 oblong bevel glass light with nickel trim and with door-opening side curtains as illustrated, or with three celluloid lights and with quick detachable panel side curtains that fold neatly between long slender panes, so they can be folded without damaging celluloid.

Will fit any 1915-24 Ford car with regular body. Shipped direct from any of our stores, which saves transportation and insures quicker delivery. Shipping weight, 80 lbs.

FOR FORD TOURING CARS

	Our Reduced Price
X8500—Touring, 1915-22, with regular panel curtains, celluloid back windows.....	24.35
X8506—Touring, 1915-22, with door-opening curtains, 7x14 bevel glass light.....	28.65
X8508—Touring, 1923-24 (with slanting windshield) door opening curtains, 7x14 bevel glass light.....	28.65

FOR FORD ROADSTERS

X8502—Roadster, 1915-22, with regular panel curtain, celluloid back windows.....	20.85
X8507—Roadster, 1915-22, with door-opening curtains, 7x14 bevel glass light.....	24.85
X8509—Roadster, 1923-24 (with slanting windshield) door opening curtains, 7x14 bevel glass light.....	24.85

Recovers for Ford \$3⁸⁵ And Up

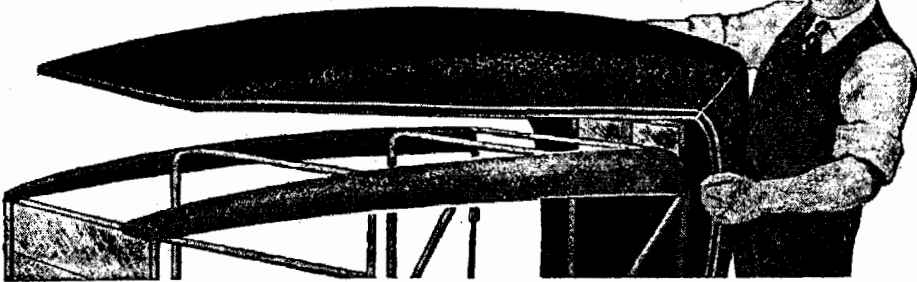

If your top has become worn, shabby in appearance, or leaky, you can quickly, easily restore both its efficiency and appearance at a very small expense by putting on one of our Ready-Made Top Recovering Outfits.

The outfit consists of an extra heavy 32-oz., high quality black rubber cloth roof and rear curtain with celluloid curtain lights, all stitched and with sufficient binding and upholstery tacks—all ready to slip right over top frame.

FORD TOURING

- F6628—Touring, 1914 to 1922, regular back curtain, 2 celluloid lights **4.95**
- F6632—Touring, 1914 to 1922, Gypsy back curtain, 2 celluloid lights **5.95**
- F6630—Touring, 1923-24, Gypsy back curtain, 2 celluloid lights, (for 1923-24 models only) **5.95**

If you want to remove old recovering, simply remove the tacks at the front and rear. The old cover will then slip right off the frame.

Our Top Outfits are cut to fit perfectly and carefully made and finished. Complete with all necessary fasteners and trimmings ready to attach. Furnished for all models of Ford Touring or Roadster, 1914 to 1924. Shipping weight, touring, 14 lbs; roadster 10 lbs.

In ordering be sure to give the year of your car so we can send you the proper size.

FORD ROADSTER

- F6622—Roadster, 1915 to 1922; regular back curtains; 2 celluloid lights **3.85**
- F6631—Roadster, 1923-24, Gypsy back curtain, 2 celluloid lights, **4.65**

F6623—Top Pads, black, touring or roadster, per pair (shipping weight 4 lbs.) 1.78

Extra Quality Top Recovers for Ford Cars

\$5⁴⁵—and UP

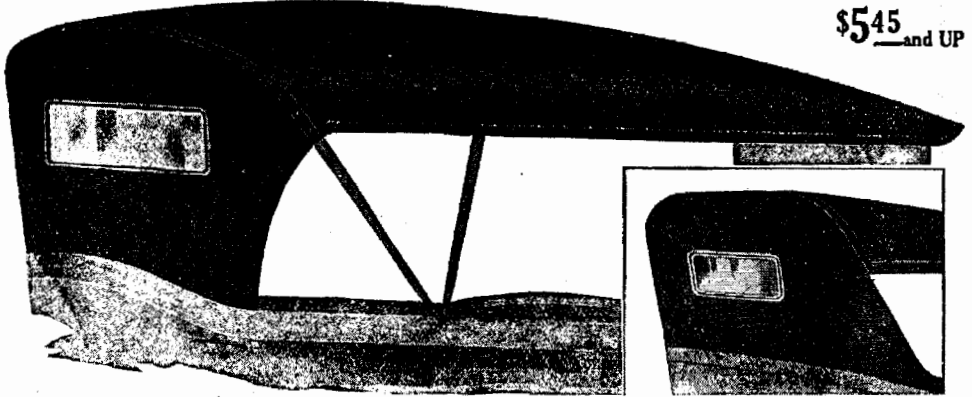

Made of best quality heavy long-grain Leatheroid top material with drab back like that used on most high-priced cars. Guaranteed to fit perfectly. Comes complete, roof and back curtain, with all necessary tacks and binding.

All back curtains are equipped with a clear glass light substantially attached to curtain and with a special reinforcement that prevents weight of glass from causing the curtain to sag or tear.

Furnished in two styles—either with regular style back curtain with a 6x18 oblong glass light with black japanned

rim, or with a gypsy style back curtain with 7x14 oblong bevel glass light with nickel-plated rim, as shown in the small illustration.

These are the highest quality top recovers made for Ford roadster or touring cars, and greatly improve the appearance of car. Please do not confuse these extra-quality outfits with the lighter-weight, rubberized cloth recovers furnished by some other houses at slightly lower prices. Average shipping weight, 16 lbs.

In ordering, be sure to give year and model of car.

FOR FORD TOURING CARS

- G7057—Long grain Leatheroid with one 6x18 oblong glass rear curtain window, 1914 to 1922 Touring **6.65**
- G7090—Long grain Leatheroid with one 7x14 oblong bevel glass rear curtain window and Gypsy style back curtain, as shown in small illustration above for 1914 to 1922 Touring Cars **7.35**
- G7091—Same as G7090, for 1923-24 Touring Cars **7.35**

FOR FORD ROADSTERS

- G7058—Long grain Leatheroid with one 6x18 glass window for 1915 to 1922 Roadster **5.45**
- G7092—Long grain Leatheroid with one 7x14 oblong bevel glass rear curtain window and gypsy style back curtain for 1915-22 Ford Roadsters **5.95**
- G7093—Same as G7092 for 1923-24 Ford Roadster **5.95**

F6624—Top pads, drab, to match any of above, touring or roadster, pair 1.78

Rear Curtains with Glass Windows

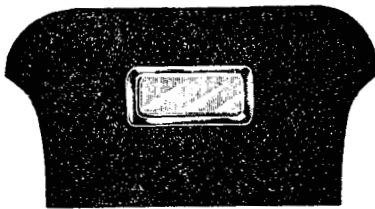

For Fords

Nothing adds more style and distinction to a car than one of our back curtains equipped with the new style

oblong bevel glass lights. The lights are there to stay, eliminating the necessity of having new celluloid put in the back curtain every few months. Easy to put on; guaranteed to fit; well-made black rubber cloth. Fitted with oblong glass light 6x18 inches. black japanned rim. Fasteners furnished. Ship. wt., 6lbs.

- F6638B—Each, for 1915 to 22 Ford Touring..... 2.68
- F6639B—For 1915-22 Ford Roadster..... 2.68

Rear Curtain for Fords

Well made of heavy rubber cloth similar to new Ford top, with good quality celluloid windows. Comes complete with tape and tacks for attaching. Easily installed. Ship wt. 4 lbs.



- F6642B—For 1913 to 1922 Ford Touring (2 lights) 1.68
- F6640B—For 1915-22 Ford Roadster (2 lights) 2.58
- F6641—For 1923-24 Roadster (2 lights) Gypsy.... 2.58
- F6643—For 1923-24 Touring (2 lights) Gypsy.... 2.58

Top Material in Bulk

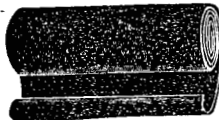

First quality heavy 34-oz. rubber cloth top material, suitable for recovering tops, patching, repairing, etc. Also fine for making waterproof covers for autos, camp outfits, trunks, etc. Comes 54 inches wide.

- Sold only by lineal yard. Ship. wt. per yd., 3½ lbs.
- X8796—Regular rubberoid pattern, 54" wide, per yd. 98c
- X8797—Long-grain finish, drab back, 54", per yd. 98c

Bow Covering Material for All Cars

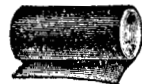

Best quality cloth for recovering automobile top bows when original material is worn or torn. Comes in strip 5½ inches wide. Fastens around bow with tacks. Easy to put on. Furnished in black or drab to match top cover.

- F6735—Bow Covering Material, black, per yd.... 8c
- F6736—Bow Covering Material, drab, per yd.... 8c

Top Webbing for All Cars

A strip of this material stretched from front to back bow on each side of your top will prevent your top cover from sagging, and keep it looking snug and neat. Best quality webbing, 1¼ inches wide; will not stretch. Ship. wt., yd., 4 oz.



- F6758—Top Webbing, black, per yard..... :10
- F6759—Top Webbing, drab, per yard..... :10

Top Quarter-Pads for Ford Cars

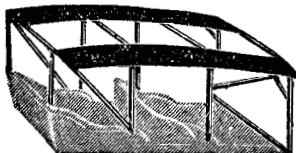

High quality quarter-pad for replacing torn or soiled pads when installing a new top recover. Add greatly to the finished appearance of the top. Ship. wt., pair, 4 lbs.

- F6623—Black, for Ford touring or roadster, pair.. 1.78
- F6624—Drab, for Ford touring or roadster, pair.. 1.78

"Gypsy" Rear Curtains for Fords

A high-grade back curtain with the new-style "Gypsy" side extensions, as used on the 1923-24 Ford and practically all large cars. Has one 7x14-inch bevel glass curtain light with nickel frame. Extra well made from heavy rubber cloth that will match the regular Ford top, and make it look like the very latest models.

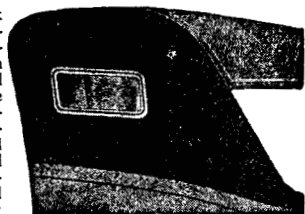

- Comes complete with tape and tacks and full instructions so anyone can put it on quickly and easily. Guaranteed to fit all Ford open cars, 1915 to 1924. Ship. wt., 6lbs.
- F6636—For 1915-22 Ford Touring..... 3.78
 - F6634—For 1923-24 Touring..... 3.78
 - F6637—For 1915-22 Ford Roadster..... 3.78
 - F6635—For 1923-24 Roadster..... 3.78

"Lift the Dot" Curtain Fasteners

"Lift the Dot" is the standard line of automobile curtain fasteners used by leading automobile manufacturers. They snap together and lock securely on their three sides but release easily by simply lifting on the fourth side, the side with the "Dot." Put on like any other curtain fastener in a few minutes. With a few of these fasteners and some of our top patching strips you can make your old curtains as good as new. Prices of fasteners do not include eyelet that clamps on curtain, which is listed separately, F6795.

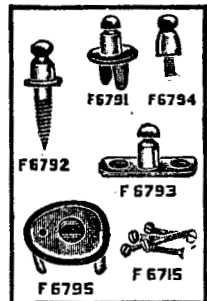

- Ship. wt. each, 2 oz.
- F6791—Cinch type, each..... 3c
- F6792—Wood Screw type, each..... 3c
- F6796—Wood Screw type for double curtain..... 3c
- F6793—Two Screw type (less screws)..... 4c
- F6797—Two Screw type for double curtain..... 4c
- F6794—Machine Screw type..... 4c
- F6795—Eyelet for any of above types..... 3c
- F6715—Screws for attaching F6793, per dozen... 7c

Curtain Fasteners

Black enamel finish, styles as shown. Prices of fasteners do not include eyelet, which is listed separately (F6717).

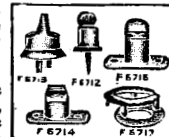

- Shipping weight, 1 oz.
- F6713—Cinch type, each..... 3c
- F6714—Two Screw type, regular, each..... 3c
- F6716—Two screw type (long, for holding double curtain), each..... 3c
- F6712—Screw type, each..... 4c
- F6717—Eyelet with washer as shown..... 3c
- F6715—Screws for attaching to bow, dozen..... 7c

Top Prop Nuts



First quality black rubber finish. Designed to replace nuts that are lost—same in appearance as those that come on the car.

- F6711—Each (ship. wt., 2 oz)..... 5c

Dixie Auto Top Protectors

A thick soft strip of high-grade felt, which fits in between the top and the cross bow, and is securely held in place by elastic clasps. Prevent top from wearing thin and breaking on the bow. Regular price, \$1.50 set.



- J7739—Set complete, (ship. wt., 1 lb.)..... .89

Curtain Lights For Ford Cars

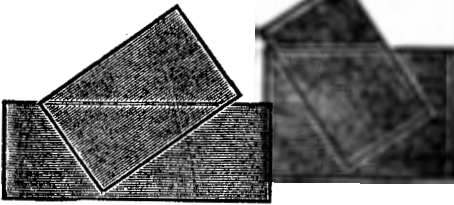

Made the proper size to fit Ford curtains, can be quickly attached by anyone with the special fasteners furnished. A broken curtain window light is very unsightly, and it is quite a task to cut celluloid and sew in the light, but with these new attachable windows the job can be done in a few minutes. Average shipping weight, 4 oz.

- F6651—Replace back curtain light for 1917 to 1922 cars; size overall 6½x10½ inches (three needed for complete set), each, clear **.20**
- F6649—Replace back curtain light for 1923-24 cars; size overall about 7½x10 inches, (two needed for set) each **.20**
- F6653—Replace large side curtain light for 1914 to 1924 cars; size about 7x20 ¼ in.; each **.39**
- F6652—Replace side curtain light for 1915-1924 cars; size overall about 10x14 ¼ in. each **.40**
- F6654—Replace side curtain light for 1914 to 1924 cars; size overall about 7x11 inches **.24**

All-In-One Rear Curtain Window SAVES TIME AND INSURES A NEAT FIT



The Sure Fit 3-in-1 Rear Curtain Light is made in one piece to replace broken curtain lights in 1917 to 1922 Ford cars. Good quality celluloid, made accurately, can be attached in two minutes

without removing back curtain; Japanese rivets furnished for fastening. Shipping weight, 1 lb.
F6657—Our Reduced Price, complete..... .60

Stick-Tite Top Patch Strips

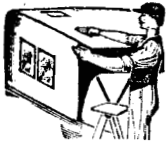

For repairing holes, breaks or rips in rubber or mohair tops, side or back curtains. Under surface has cement coating protected by thin sheeting. Applied just like an ordinary tube

- patch. Full instructions. Shipping weight, 4 oz.
- F6707—Rubber Strip, each 6x9 inches **.28**
- F6709—Rubber Strip, 6x18 inches **.58**
- F6705—Rubber Strip, 2x36in. (for tears over bows) **.58**
- F6708—Mohair Strip, each 3x12 inches **.28**
- F6710—Mohair Strip, 6x18 inches **.28**
- F6703—Long grain leatheroid strip, 3x12 inches.... **.48**
- F6704—Long grain leatheroid strip, 6x18 inches . . **.48**
- F6706—Long grain leatheroid strips, 2x36 inches **.58**

Rain Guard for Ford Cars

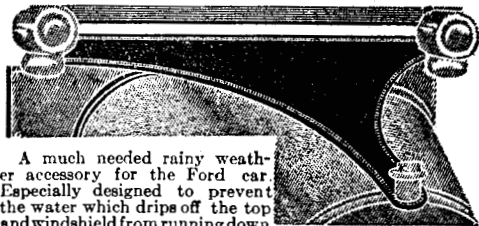

A much needed rainy weather accessory for the Ford car. Especially designed to prevent the water which drips off the top and windshield from running down the outside of the dash, and under the hood to the wiring.

Ford owners will quickly appreciate this article, as it prevents the stalling of the motor in rainy weather.

- Back edge fastens under windshield; front edge fastens over radiator neck. Does not prevent raising the hood easily. Made of soft, flexible, durable Ford top material. Shipping weight, 2 lbs. **Our Reduced Price**
- F6678—For Touring, Roadster or Coupe 1915-24. . . **.80**
- C5679—For Sedans 1915 to 1924 **.90**

Glass Rear Curtain Lights

FOR POPULAR CARS

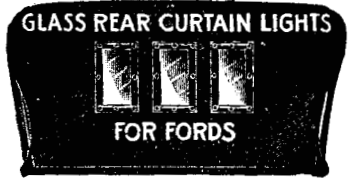

Replace torn worn-out celluloid curtain lights with these smart glass lights. Protect from weather as well as adding greatly to the appearance of your car. Add safety to driving, as they give you a clearer rear view. Will

outwear celluloid several times. Will not tear or sag curtains. Glass fits present openings. Made with strong metal frames, beautifully black enameled, one on the outside and one on the inside. They clamp tightly together to curtains with eight screws. Quickly and easily attached. A screw driver is the only tool necessary. Carefully packed, complete with screws for attaching. Shipping weight, 4 lbs.

- F6659—Set of Two Lights, 1923-24 Fords. **.49**
- F6658—Set of Three Lights 1917-22 Fords. **.58**
- F6679—Extra glass light, Glass only, for Ford sets. State exact size of glass when ordering. Each **.10**
- F6678—Glass Rear Curtain Light, 6x18 in., for Chevrolet, Dort, Durant 4, Gardner and Star **1.28**
- F6677—Set of 2 lights for Overland 1921-22-23, size of glass 14½"x6". Weight 51 lbs. **1.48**

Celluloid Extra Quality

Extra heavy clear celluloid in proper sized sheets for replacing broken lights and curtains. Save one-half by inserting the celluloid yourself. W8402—

- Size 12x20 in. **.36**
(Weight 8 oz.)
- Size 24x20 in. **.68**
(Weight 1 lb.)
- Size 50x20 (wt. 2 lbs.) **1.24**



La France Waterproof Glue



For Patching Tops, Tents, etc

A wonderfully effective waterproof glue, for patching canvas or fabric goods, wood, crockery, or in fact anything around the house or garage except rubber. Outfit consists of ¼-pint can of glue and about 36 sq.in. of treated fabric for use in patching auto tops, etc. Absolutely guaranteed. (Ship. wt., 1 lb.)

- G7096—Outfit complete, with black fabric **.44**
- G7097—Outfit complete, with drab fabric. **.44**

Upholstery Tape and Tacks



A large roll of black upholstery tape and package of upholstery tacks for renewing binding on Ford cushions, back of seats, doors and inside of body. Shipping wt., 8 oz.

- F6692—Tape with cord in edge, 25 ft. roll **.32**
- F6693—Plain Flat Tape, 25 ft. roll **.22**
- F6694—Box 50 Tacks **.10**

"Hide-the-Tack" Tape and Tips

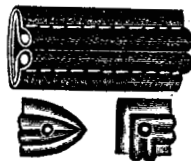

This is a heavy upholstery tape with two rolls that come together in center and cover up tack heads. Rolls are raised up while tacks are being inserted. We also furnish fancy black Japan metal tips to cover ends or corners when using this tape around door panels or seat upholstering. Ship. wt. yd., 3 oz.

- F6681—Hide-the-Tack Tape, per yard. **.10**
- F6682—Metal tips for ends, per doz. **.25**
- F6683—Metal tips for corner, per doz. **.25**

“Ride-Easy” Extra Quality Cushions for Ford Cars

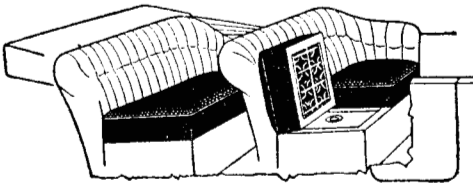

Nothing does more to spoil the pleasure of a drive than bumping about on hard, sunken uncomfortable cushions. You can save discomfort and annoyance and add to the appearance of your car by replacing the worn out cushions with our “Ride-Easy.”

The “Ride-Easy” cushions are made to fill the long-felt demand for a better cushion for Ford cars. The frame is extra heavy, with strong cross braces of wood and steel. The highly-tempered coil springs are stronger and more substantial and are fastened securely in place by a network of steel wire, which not only prevents the springs from slipping but serves as a support and re-inforcement for the well padded, hair-filled, leatherette top.

This makes a cushion that is sagless and practically indestructible. For real comfort and long service our “Ride-Easy” cushions are equal to any cushion on the market, regardless of name or price. After riding on one you will wonder there could be so much difference in cushions.

Front cushions can be furnished in the regular one-piece style, or in two sections as illustrated, which allows the gas tank to be filled without disturbing the driver’s seat. Average shipping weight, 18 lbs.

	FOR 1909-21 FORD CARS	Our Reduced Price
W8347—Cushion, one-piece, touring front or roadster, 1909-1921 Fords (unavailable)		4.95
W8348—Cushion, two-piece, touring front or roadster, 1909-1921 Fords, complete		5.35
W8349—Cushion, one-piece, touring rear, 1909-1921 Fords. (unavailable)		5.15
	FOR 1922-24 FORD CARS	
W8352—Cushion, one-piece, touring front or roadster, 1922-24 Fords (unavailable)		4.95
W8353—Cushion, two-piece, touring front or roadster, 1922-24 Fords, complete		5.35
W8354—Cushion, one-piece, touring rear, 1922-24 Fords (unavailable)		5.15

Window Curtains for Closed Cars

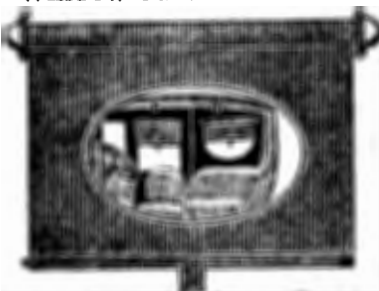

Made of a new curtain fabric which is waterproofed and specially embossed to produce a finish that is far superior to the “Silk” formerly used for auto curtains. This material

will not fade or rot from the sun, will not tear, and if soiled can be cleaned by use of soap and water. Have pull tabs and are furnished complete with rollers and brackets. Roll up like regular window shades. Protect from sun and add to the comfort and appearance of the interior of the car. Prices shown are for complete curtain and roller. Shipping weight about 3 pounds each.

D6211—Satin-finish Curtain, 14” wide, 28” long (fits side window of Ford coupe, 1916-24), each	1.90
D6212—Satin-finish Curtain, 21” wide, 28” long (fits side window of Ford sedan, except Tudor), each	1.95
D6213—Satin-finish Curtain, 27 1/4” wide, 21” long (fits rear window of any Ford sedan or coupe), each	2.65
D6214—Satin-finish Curtain, 32” wide, 26” long (fits side window of new Ford Tudor sedan (coach), each	2.95
X8837—Satin-finish Curtain, for door or window of any other car (give year and model of car), each	3.55

SILK CURTAINS

D6216—Silk Curtain, 14” wide, 28” long (fits side window of Ford coupe, 1916-23), each	1.90
D6217—Silk Curtain, 21” wide, 28” long (fits side window of Ford sedan, except Tudor), each	1.95
D6218—Silk Curtain, 27 1/4” wide, 21” long (fits rear window of Ford sedan or coupe), each	2.65
D6219—Silk Curtain, 32” wide, 26” long fits side window of new Ford Tudor sedan (coach), each	2.95
X8838—Silk Curtain, for door or window of any other car (give year and model of car), each	3.35

Door Protector Pad



Fits on the door where you always put your hand when getting in or out of your car. It protects the finish on the door and adds to the appearance of the car. Made of high grade imitation leather neatly bound

around a metal plate which serves to hold the shape. Wt. 8 oz.	
F6680—Rubberoid with tin plate, about 5x6 in., each	1.10
F6684—Heavy imitation leather about 6x8 in., with lead plate, each	34

Super Quality Fibre Door Panels

For Open Model Ford Cars 1915 to 1924

Every Ford owner knows how quickly the regular grade door panels in his car are kicked out and broken until they present a very bad appearance. Our fibre door panels were designed for the man who wants a high quality, long-wearing article, that will not have to be renewed every few months. They are not the ordinary cardboard with a black covering, but are a special hard fibre that will last much longer than the ordinary kind. Can be put on by anyone in a few minutes. Av. ship. wt., 1 lb.

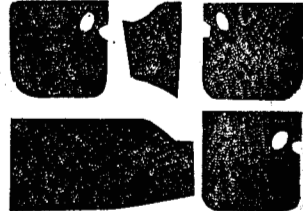

F6760—Left front panel, each38
F6761—Right front side panel door to dash14
F6762—Right front door panel29
F6763—Right rear door panel32
F6764—Left rear door panel32
F6765—Complete set for Ford touring car, (5 lbs.)	2.85
F6766—Complete set for Ford roadster, (wt. 3 lbs.)68

CUSHION UPHOLSTERING ASSEMBLY for Ford Cars



Made of high grade cushion material and packing that is of extra quality and will not get hard and lumpy. Comes tufted with black buttons, complete with packing, tacks, and tapeready to put on. Can be put on by anyone in a few minutes and will make the inside of your car look like new. Furnished for 1915 and later cars only. Shipping weight, each, about 7 lbs.

W8391—Complete assembly for front seat of Ford Touring cars 1915-24 and Ford roadsters 1915-24	3.85
W8392—Complete assembly for rear seat of Ford touring 1915-24	4.10

Handy Auto Ash Tray

An attractive-looking combination ash receiver and match box holder, which can be fastened at any convenient point in the car. Made from heavy sheet brass, and heavily nickel-plated. Ash receptacle is made in two pieces, so it is easily removed for cleaning. Strong metal clip holds match box in place. Complete with screws for attaching.

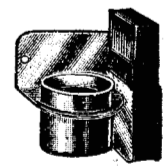

G7012—Each, complete (ship. wt., 12 oz.)68
--	-----

Pontiac Top Support

For Ford Open Cars

Prolongs the life of your top by providing a rigid, secure fastening, like the present tops. Stops rattling and swaying and eliminates the danger of accidents due to top coming unhooked on rough roads. Supports are double drop-forged and are finished in black enamel. Makes driving safer and improves the appearance of your car. Complete with instructions. No drilling necessary. Weight, 4 lbs.

E6550—Set complete for Ford open cars, 1917-22... **1.18**

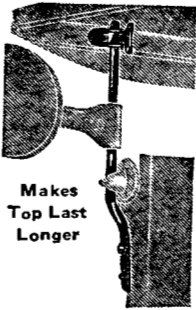

Makes Top Last Longer

Snap On Top Springs



To replace the front top straps on any Ford open car. Snap on easily and can't shake loose. They take up most of the shock and vibration that the top now receives and thus lengthen the life of your top.

F6676—Per pair complete. (Ship. wt. 1 lb.)..... **.45**

Top Strap Springs

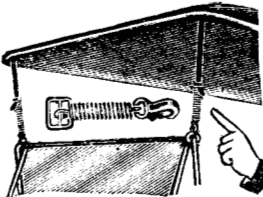

A real necessity to prevent jerks on rough roads from straining or tearing the top. When the car goes over a twisting place these springs give and relieve the strain on the top and straps. Also they always insure good tension on the straps, keeping the top tight. Nicely finished.

F6700—Set of 2 (Ship. wt., 8 oz.)..... **.49**

Top Straps for Ford Cars

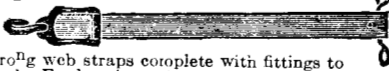

Extra strong web straps complete with fittings to replace regular Ford equipment.

F6697—Front, each (shipping wt., 8 oz.)..... **.16**
 F6698—Rear, each (shipping wt., 8 oz.)..... **.23**

Rubber Auto Bumpers for All Cars

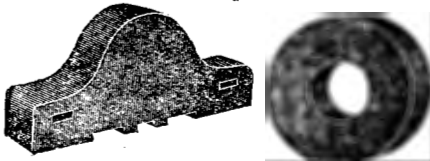

For use between the springs of large cars to prevent broken springs and make the car ride easier. Made of first quality stock. Ship. wt. 2 1/2 lbs.

K8018—Round Type—2 1/2 in. high by 1 1/2 in. wide... **.42**
 K8019—Round Type, 3 1/2 in. high by 1 1/2 in. wide... **.47**
 K8020—Long Type, 6 1/2" long, 3" high, 1 1/4" thick... **.55**

Linoleum for Running Boards



This heavy gray linoleum will give your running boards a new bright finish and add greatly to the appearance of the car.

It lasts well, is easily cleaned, and is not affected by grease, oil or water. Shipping weight per sheet, 6 lbs. **Our Reduced Price**
 X8757—Sheet linoleum, 12"x72", each..... **.90**

Body Rails for All Cars

Protect Finish from Scratches and Dents

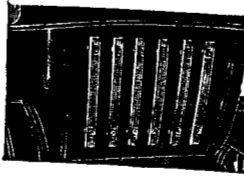

Beautiful polished aluminum body rails, such as are used as regular equipment on the late model high-priced cars. Each rail is 3/4 inch wide and 20 inches long, and is complete with two toggle-joint bolts, so rails can be easily installed by drilling holes in back of car without touching the

upholstery. Ship. wt., 4 lbs.
 X8794—20" long, set of six, complete..... **3.55**
 X8795—9 1/2" long, set of six, complete..... **3.25**

Arm Rests for Closed Cars

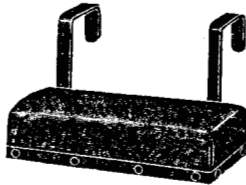

A great comfort for driver or passenger. Almost indispensable on long trips. Handsomely upholstered in substantial imitation leather, with thick-piled high-grade filler. Black enameled brackets, about 4 inches long. Can be put on in a minute. Will outlast the car. Ship. wt., 2 lbs.

E6597—Arm rest as illustrated, each..... **.68**

Door Pockets for Ford Open Cars

A neat, practical and valuable requisite for Ford cars. Made of a good strong artificial leather.

Fasten to doors with upholstery tacks; quickly removed if desired. Large, convenient pocket, reinforced with heavy cardboard, so it holds its shape and presents a more attractive appearance. Ship. wt., 2 lbs.

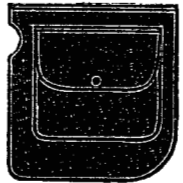

For Ford Touring or Roadster
 F6666—Right Front, each... **.54**
 F6667—Left Front, each... **.54**
 F6668—Right Rear, each... **.54**
 F6669—Left Rear, each... **.54**

Door Pockets for Ford Closed Cars

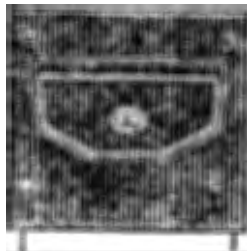

For all models Ford Sedan or Coupe. Made of same material as upholstery in late model Ford cars. Can be put on in a minute by anyone. Simply push metal fasteners at lower corners of pockets into upholstery and tack upper corners to door. Size over all 12 in. high, 15 in. wide. Large roomy pocket with flaps and turn button fastener. Ship. wt. 3 lbs.

F6686—Our Reduced Price, each..... **1.65**

Closed Car Door Straps



Strong, substantial leather strap, complete with metal loop at each end, to check doors of closed cars from swinging too far open and damaging the finish. Length, 8 inches.

F6699—Strap, complete as shown (ship. wt., 8 oz.)... **.22**

Moulding for Running Boards

Heavy, highly polished aluminum moulding for covering edges of linoleum on running boards. Furnished only in 6-foot lengths. Ship. wt., 1 lb.
 X8758—Hook-edge moulding, plain, 3/4"x3/4", 6-ft. length, each **50c**; per pair..... **.89**
 X8759—Corrugated moulding, 3/8"x3/4", 6-foot lengths each **60c**; per pair..... **1.10**

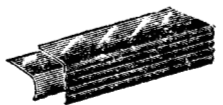

Rear-Vu Mirror
For All Open and Closed Cars

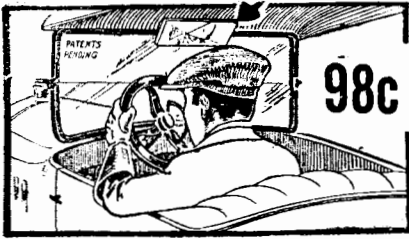

A mirror is absolutely necessary to protect yourself from the carelessness of the driver behind you. Our Rear-vu mirror is so constructed that it may be set at any angle without mechanical adjustment or undue strain on the glass. Only one screw and nut used in its assembly. The metal parts are of spring brass and bronze, nickel plated, so that they will not rust. Glass is highest grade crystal plate, size 2 1/4 x 7 inches. Put one on your car and guard yourself against rear-end smash-ups. Ship. wt., 3 lbs.

A5146—Open car type, **98**
A5147—Closed car type with regular style bracket which holds mirror about even with top of windshield, ... **98**
A5148—Closed car type with extension bracket which holds mirror about 2 1/2 in. below top of windshield, ... **98**

Superior Rear-View Mirror
For the Man Who Wants the Best

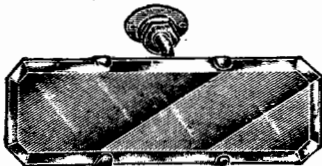

A mirror for the man who wants the best. Neatly shaped and made in heavy plate glass with 1/4-inch bevel. Bracket made entirely of brass, handsomely finished. Mirror has leatherette

protection in back to prevent scratches or dampness from affecting the silvering. Shipping weight, 3 lbs.

A5153—For open cars, **1.85**
A5154—For closed cars, **1.85**

Rear View Mirrors
Prevent Many Serious Accidents



89c And Up

A mirror is a great factor for safety in driving. With one you know what approaches at the rear; without one you either guess or crane your neck and lose sight of the road ahead. Our mirrors clamp rigidly to the side of any windshield and are adjustable to any position. They show objects natural size and are much plainer than the old-style convex. Average shipping weight, 2 lbs.

A5120—4" Round, **.89**
A5122—5" Round Bevel Plate, **1.95**
A5123—4x6 Oval Bevel Plate, **1.65**
A5127—Special mirror for trucks, 5-inch, **1.65**
A5130—Extra bracket, 24 inches long, to fit A5127, for use on trucks with extra large body, **.40**

Genuine Aermore Exhaust Horns
"THE HORN WITH THE LOCOMOTIVE TOOT"



The Aermore Exhaust Horn is constructed of four brass tubes, heavily nickel-plated, that produce a harmonious signal that is always audible above the din of congested traffic—can be heard a mile or a block away. The Aermore warns, but does not frighten. It is the horn with the locomotive toot. It is attached to the exhaust pipe in front of the muffler by a regular 3-way horn valve. It requires less pressure to operate than any other horn on the market. Easy to install. Comes complete with pedal, cable, pulley and full instructions. Average shipping weight, about 8 lbs.

Give make and model of car and **Outside diameter of exhaust pipe** when ordering. **Our Reduced Price**

B5455—13-inch horn, for Ford cars, complete with 1 1/4-inch valve, **4.95**
B5454—13-inch horn, for any other small car, complete with any size valve, **5.15**
B5461—15-inch horn, for medium cars and light tractors, complete with any size valve, **8.45**
B5460—17-inch horn, for large cars and heavy tractors, complete with any size valve, **9.65**

Valves For Exhaust Horn

Valve only for exhaust horn—fits Aermore and other similar horns. Accurately made, with strong spring to keep horn valve closed when not in operation. **In ordering, be sure to give year and model of car and outside diameter of exhaust pipe.** Shipping weight, 3 lbs.

B5453—Valve only, **1.65**

Mocking Bird Exhaust Whistle

Everybody who hears this whistle wants one. It has eight beautiful distinct tones in one horn. A signal that warns pedestrians, but does not offend. Not shrill and harsh, but soft and distinct. It screws into the exhaust manifold and extends upward. The valve is controlled by a cord. A slight pull gives a low, soft warning, which will not frighten people at close range, while a sharp jerk on the cord will make you "jump out of your hide." By varying the pull on the cord which operates the plunger in the whistle you get eight different tones and with a little practice you can almost "mock the mocking-bird." Shipping weight, 2 lbs.

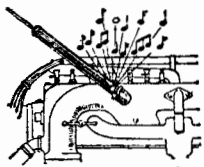

B5452—Mocking-Bird Whistle, **.98**

Moto Explosion Whistle

This is a very popular whistle and a most effective warning signal. It is installed in place of a priming cup in motors which have priming cups. Otherwise it is connected to a special adapter or spark plug extension. The whistle utilizes the explosion pressure and makes a very loud, sharp sound. An ideal signal for all cars, including trucks. It is practically indestructible and will last indefinitely with no expense for operation. The valve is made of cast bronze and bowl of whistle is polished cast aluminum. Every part is high-grade material and nicely finished. Shipping weight, 2 lbs.



B5451—Whistle only, as shown, **1.48**
B5448—Whistle with adapter for Fords, **1.85**
B5450—Whistle with adapter for 3/8-inch plug, .. **1.85**

Western Giant Motor-Driven Horn

This is undoubtedly the best horn value we have ever offered. It is made for us by one of the oldest manufacturers of warning signals. Workmanship and material are of the very best, and every horn is carefully made and assembled under expert supervision.

Attractive in design, and has a loud, clear, "road-getting" sound that is audible for a great distance. The sound is produced by the rotation of an electric motor against the horn diaphragm, so that the quality of the tone can be varied by a simple adjustment.

Nicely finished in durable black enamel. Comes equipped with bracket, either for mounting on dash or on engine head bolt. Shipping weight, 8 lbs.

- B5431—6-volt, with dash-mounting bracket... **5.95**
- B5439—6-volt, with motor-mounting bracket... **5.95**
- B5432—12-volt, with dash-mounting bracket... **5.95**

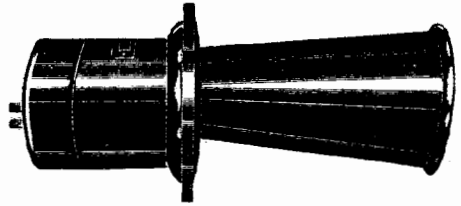

\$5.95 For Any Car

Commander Motor Driven Horn

For All Cars

\$2.95

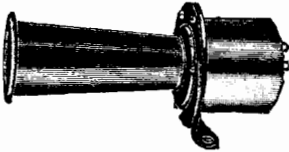

A motor-driven horn, with true motor-horn warning tone. A well-known standard motor horn, sold under our guarantee. B5433 and B5438 operate from 6-8 volt storage battery or four to six dry cells. B5434 operates from 12-volt storage battery. Furnished in black enamel, with torpedo-type tapered projector. Substantially made of high-grade material and will not easily get out of order. Complete with bracket. Positively cannot jar loose. Length over all, about 12 inches. Shipping weight, 5 lbs.

- B5433—6-volt, with motor-mounting bracket; fits all cars except those with overhead valves... **2.95**
- B5438—6-volt, with bracket for mounting on dash... **2.95**
- B5434—12-volt, with dash-mounting bracket... **3.35**

Electric Vibrator Horn

\$1.38

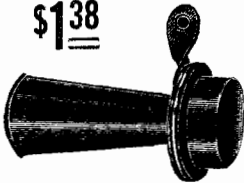

For use with 6-volt storage battery. Same horn as is now used as regular equipment on Ford cars with starter. Gives loud warning signal. Tightly sealed so that it is not affected by dust, rain or climatic conditions. Cannot get out of adjustment. Requires no oiling or other

attention. Will last for life of car. Comes complete with bracket for attaching to dash, in regular place. Well finished in black enamel. Shipping weight, 3 lbs.

- B5437—Our Reduced Price... **1.38**

Universal Push Button

An excellent button for horns, bells, etc. Easy to work as the whole top is movable, so that the contact is made when it is compressed at any point. Button shell finished in beautiful black enamel and top is a black composition making the article neat and attractive. Easy to operate and install. Ship. wt., 4 oz.



- C5792—Our Reduced Price, each... **.24**

Horn Push Button

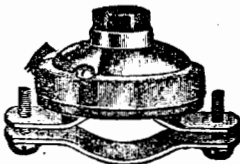

Used with electric horns of all kinds. Can be clamped to spoke of steering wheel or can be attached to any flat surface by removing clamp. Diameter 1 1/4 inches. Nicely finished. Shipping weight, 4 oz.

- C5742—Each... **.32**

Genuine EA Motor Driven Horn

For All Cars

\$4.45

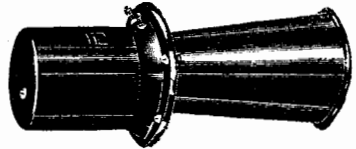

Everyone is familiar with the high quality and dependability of EA Horns. They may cost a little more, but give better service and last so much longer that they will be found cheapest in the long run.

This is a new improved model, for use on any car. Operates from 6-8 volt storage battery or 4 to 6 ordinary dry cells. Beautiful black enamel finish. Gives loud, clear warning. Ship. wt., 4 lbs.

- B5435—6-volt, with motor-mounting bracket; fits all cars except those with overhead valves... **4.45**
- B5436—6-volt, with bracket for mounting on dash... **4.45**

"Superior" Hand Horn

\$2.45

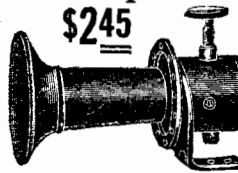

A big, handsome dependable horn. Produces a long rolling blast as well as a short, unannoying signal. Will not rattle and the mechanism is water-proof. Guaranteed to last as long as your car. Nice black enamel finish. Size, 9 inches long.

Its action is easy; you do not have to push hard. No batteries needed with this horn; costs nothing to operate. Bracket furnished for attaching. Shipping weight 4 lbs.

- B5430—Each, complete... **2.45**

Steering Post Horn Button for Ford, Dodge and Chevrolet Cars

Replaces the nut that holds the steering wheel in the center, where it can be easily reached with either hand. Comes complete with enough wire to attach to wires of regular equipment. Anyone can install it in a few minutes. Beautifully nickel-plated, well-made. Shipping weight, 8 oz.



- C5740—For Ford and Dodge cars... **.29**
- C5741—For Chevrolet 490 and Superior... **.39**

Horn Button and Throttle Extension

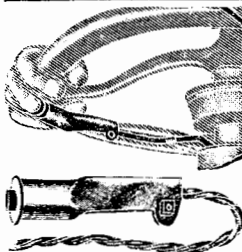

Clamps on Ford throttle lever, making it longer and easier to reach to control the gas, also put horn button in a convenient place. Highly polished, nickel-plated finish. Strong and substantial. Ship. wt., 8 oz.

- C5739—For Ford cars only. Each... **.42**

"Twin-Steel" Spring Bumpers

FOR ALL CARS

\$8.95 AND UP

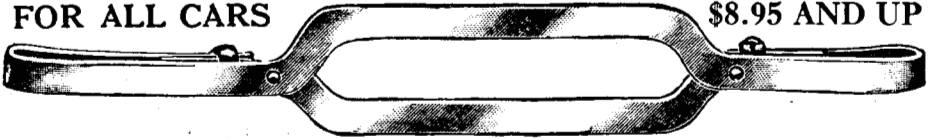

Every car should have a front and rear bumper. You may be a very careful driver and yet you never know what some careless driver in front or behind you will do. With the ever-increasing number of cars and congested traffic, both in the city and country, accidents are rapidly increasing, making it necessary for the careful driver to protect himself and car from the carelessness of the "other fellow."

Of all the bumpers in use to-day the most practical and satisfactory is a steel spring bumper, because it will bend when it strikes an object and then spring back to its original shape, without damage to the car or bumper.

Our "Twin-Steel" Spring Bumper is one of the strongest bumpers made. The bar is strong and durable, and the fittings are simple and strong, so that when attached the bumper really becomes a part of the car and is so rigid that there is no rattle or jar. Both bars and arms are made of high carbon spring steel, heat treated and oil tempered. The greatest indorsement for spring bumpers is the fact that most insurance companies reduce their accident and collision insurance premiums 15% on all cars equipped with steel spring bumpers.

The "Twin-Steel" style bumper is one of the most popular of all the various spring bumpers. By having the bars spread

apart it gives added protection and prevents the bumper of another car from slipping under it or over it and damaging the car.

Easy to attach without drilling or any machine work. Bar made of special spring steel, handsomely nickel-plated. Adds greatly to the appearance of any car. Furnished for practically any car made.

This is one of the strongest bumpers made, and is fully guaranteed against breakage. **We will replace absolutely free, any Twin-Steel Bumper which may be damaged, even through collision or accident.**

W8464—"Twin-Steel" Nickel Bumper (1 $\frac{3}{4}$ "-in. bar) for front or rear of Ford, Chevrolet 490 and Superior, Star, Gray and 1920-24 Overland, complete with arms (wt. 40 lbs.) **8.95**

W8454—New "Sport" Model "Twin-Steel" Bumper, (1 $\frac{3}{4}$ " bar) similar to above except with strong reinforcing bar running across back. For any car **except** Ford, Chevrolet 490 or Superior, Star, Gray or 1920-24 Overland, complete with arms, (ship. wt. 45 lbs.) **10.95**

W8455—Sport model Bumper same as W8454 except with 2 $\frac{1}{4}$ " bar (ship. wt. 52 lbs) **16.85**

"Stronghold" Spring Steel Bumpers

\$6.95

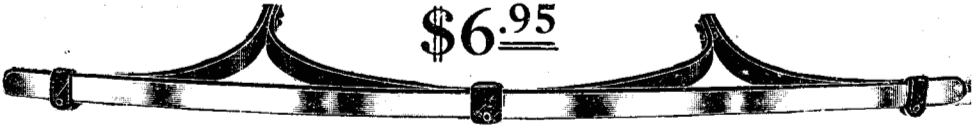

A new style of spring steel bumpers, made of tempered steel, unusually well braced and reinforced. It gives maximum protection and greatly improves the appearance of the car. Can be attached in a few minutes without drilling or machine work. An entirely new design of arm holds the bumper solid and firm, eliminating vibration and side sway. Will not rattle. Furnished with all nickel bar and black braces, as illustrated. Guaranteed against breakage. Every bumper furnished complete with arms and full instructions for attaching. Shipping weight, 30 lbs.

We will gladly replace absolutely free any Stronghold Bumper or part which may be damaged even through collision or accident.

W8465—Complete Bumper for front or rear of Ford, Chevrolet 490 or Superior, Gray or 1920-24 Overland, complete with arms, **6.95**

Not furnished for any car other than those listed above.

"Double-Guard" Spring Steel Bumpers



The very latest style in spring bumper manufacture. Same high-grade materials and workmanship as our "Twin-Steel" shown above. Has two 1 $\frac{3}{4}$ -inch nickel-plated bars running full length, securely bolted together, with strong reinforcing bar at back which is bolted to arms. We know of no stronger or more substantial bumper made, regardless of name or price.

Every bumper furnished complete with arms and full instructions for attaching. Can be easily and quickly installed by anyone. Will not vibrate or rattle, and is fully guaranteed against breakage.

We will gladly replace, absolutely free, any Double-Guard Bumper or part which may be damaged even through collision or accident.

W8451—Complete Bumper, (1 $\frac{3}{4}$ " Bar) for Ford, Chevrolet 490 and Superior, Gray, and 1920-24 Overland, **10.65**

W8452—Complete Bumper (1 $\frac{3}{4}$ " bar) for any car **except** Ford, Chevrolet 490 or Superior, Star, Gray or 1920-24 Overland, **13.35**

W8453—Complete Bumper, same as W8452, except with 2" bar **16.85**

SPECIAL NOTE

In ordering any bumper on this page be sure to specify make, year, and model of car and whether for front or rear. If your car is equipped with snubbers please specify. **BUMPERS CANNOT BE SENT BY MAIL.**

Any bumper listed will be installed at any of our stores for \$1.00 each extra.

Western Giant Spring Steel Bumpers

Guaranteed
Against Breakage

FOR ALL CARS

\$8⁹⁵ and up

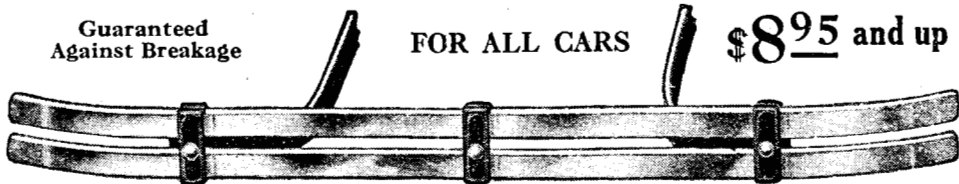

Our Western Giant Spring Steel Bumper is an exceptional bumper value, made possible only by our direct-from-factory-direct-to-car-owner system of distribution. It combines all the advantages of a high-grade spring-steel bumper that is practically unbreakable, with the popular parallel-bar style, at an unusually low price.

Bars are made of best-quality spring steel, specially treated and tempered. The parallel bars afford maximum protection, by preventing the bumper of another car from slipping over or under it and damaging your car.

The arms and fittings are specially designed and are unusually solid and substantial. We can recommend our Western Giant Bumper to Ford and Chevrolet owners who have had trouble with bumpers that vibrated and shook loose. It is absolutely guaranteed, too, against breakage, even in collision or accident.

The bars are handsomely and durably nickel-plated, with black-enamelled cross-bars and arms, making the bumper exceptionally attractive in appearance, and an ornament to any car.

We will gladly replace absolutely free any Western Giant Bumper or part which may be damaged, even through collision or accident.

Easily installed by anyone, as no machine work is required. Every bumper comes complete with arms and full instructions for installing.

In ordering be sure to specify make, year and model of car and whether for front or rear. If your car is equipped with snubbers please specify on your order. BUMPERS CANNOT BE SENT BY MAIL.

- W8480**—"Western Giant" Bumper, 1 3/4-inch nickeled bars, for front or rear of Ford, Chevrolet 490 or Superior, or Star, complete with arms (ship. wt., 30 lbs.)..... **8.95**
- W8467**—"Western Giant" Bumper, 1 3/4-inch nickeled bars, for front or rear of any other car (ship. wt., 40 lbs.)..... **11.65**

Any Bumper shown above installed at any of our stores for \$1.00 each extra.

Extra Large Steering Wheels FOR FORD CARS

17-inch Corrugated, with Aluminum Spider

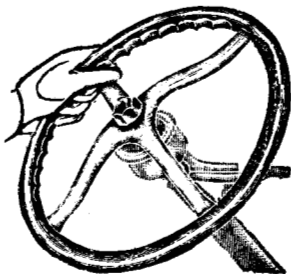

You will be delighted and surprised at the appearance and advantage of our Safety Steering Wheel. The extra size permits of quicker and easier steering, more comfort and safety. Well made of fine material, beautifully polished, walnut finish, 17-inch corrugated permitting better grip. Spider made of polished aluminum. Easy to install; carefully machined so that no fitting is necessary. Ship. wt., 5 lbs.

Our Reduced Price

- A5131**—Wheel with Aluminum Spider..... **1.98**

Throttle Extensions

It is very hard to reach the throttle on a Ford especially when an oversize steering wheel is used. This device makes it easy and will make driving a much greater pleasure. Made of polished aluminum. Shipping weight, 2 oz.



- J7652**—Our Reduced Price, each..... **18**

Starting Crank Holder

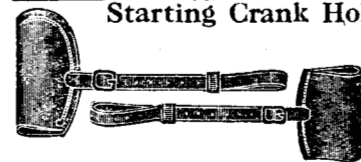

Keeps the crank out of the mud. Stops the annoyance of a flopping starting crank. Prevents hammering against the crank shaft.

Our Reduced Price

- B5289**—Small, both ends open..... **15**
- B5290**—Large, one end enclosed..... **18**

Steering Wheel Grip For All Cars

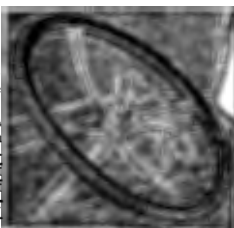

A high quality elastic rubber cover that gives a positive easy grip on the steering wheel. Warmer on hands in winter; more comfortable in summer. Black, nicely finished; adds to appearance of car, as well as to safety of driving. Will not stretch or lose shape; will last indefinitely. Shipping weight, 1 lb.

- D6078**—16" size (regular Ford size)..... **1.29**
- D6079**—For 17" or 18" steering wheels..... **1.29**

Front License Bracket Fits Around Radiator Neck



A handy, well-made license bracket, which attaches around the radiator neck of Ford cars. Nicely finished in black-enamel. Fits snugly; won't rattle. Complete with bolts for attaching.

Our Reduced Price

- A5105**—Each (ship. wt., 1 lb.)..... **.28**

Front License Bracket

Held by nut on bottom of headlight post, and extends downward, holding license in a good position. Complete with bolts for attaching license plate. Shipping weight 1 lb.

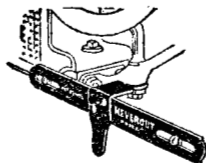

- A5106**—Each..... **.18**

Door Pull Handle

Handy door pull handle for doors or windows of closed cars. Made of brass, nickel-plated; 3 inches long. Ship. wt., 8 oz.



- A5140**—Each, **Our Reduced Price**..... **.35**

"PERFECTION" SHOCK ABSORBERS

FOR FORD CARS

Our "Perfection" shock absorbers have no superior. They aid the original Ford spring to withstand all road strains and shocks, either up or down. They provide a positive rebound check, which prevents upthrow and broken springs, since it is well known that it is the rebound that breaks the spring.

They are designed along the latest approved lines. No coil springs to break or lose, but a flat-spring construction that serves to add more than 20 inches to the regular spring suspension, cushioning shocks even under a heavy overload, without side-sway or rebound, or tilting on short turns. Do not interfere with the regular spring in any way, as the inner end glides freely over the spring on snugly fitted ball bearings.

"Perfection" shock absorbers are one of the neatest-appearing on the market. They require no special tools for installation, and no extra labor when overhauling car—only

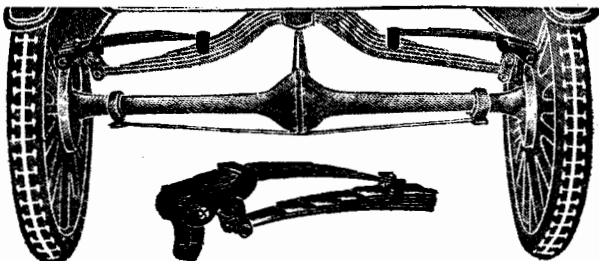

two points of attachment. Nothing to lose or get out of order. Absolutely guaranteed against defects of workmanship or material. Will last indefinitely and pay for themselves many times over in saving on tires and upkeep, besides the comfort of easy riding. Ship. wt., 24 lbs.

A5203—Complete set for any Ford car 7.95

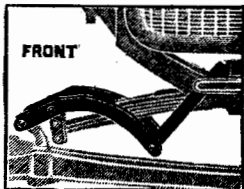

flexible bruises which cause blow-outs and ruined tires. Vibration is also lessened, preventing much strain and wear on motor, transmission, frame and body.

Flexible Rider Double-Arm Shock Absorbers will soon pay for themselves in the saving of wear and tear alone, not to mention the great comfort they afford. We believe them to be one of the best shock absorber values ever offered to Ford owners, being equal in every way to many shock absorbers offered by others at \$8 to \$10. Well made of strong pressed steel, with special tempered springs; nicely finished in black enamel. The perches are made of drop-forged steel and the bolts of high-carbon steel, with a new improved locking device to prevent loosening. Easy to install; no holes to drill. Come all ready to attach, with full instructions.

A5200—Complete set for 1909-23 Fords (ship. wt., 18 lbs.) 4.35

Flexible-Rider Double-Arm Shock Absorbers

For 1909-23 Ford Cars

Suspend all four corners of the body on flexible cushion springs, which absorb the slightest or heaviest jolts, so that, instead of "bumping," the car seems to ride like a boat. They also save your tires, which are relieved of the strain from the car bouncing, as well as having road-shocks lessened—will prevent practically all of the

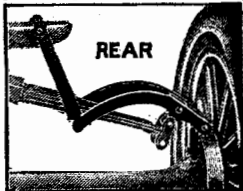

"FLEX O-PLANE" SHOCK ABSORBERS

This is the very finest grade double arm shock absorber made. Same style as our Flexible-Rider shown above, except of better material and workmanship. The arms are strong, tough malleable castings which are preferred by some to the pressed steel type. The arms are very beautifully curved and tapered, making the "Flex-O-Plane" a very attractive shock absorber. The springs are especially flexible and easy riding. The rear perch bolts are fitted with compression grease cups; the front perch bolts and all shackles have oilers. This feature is very valuable, as it

permits of proper lubrication, and the shock absorbers last much longer. All shackle bearings have bronze bushings. Complete with full instructions for installing. Shipping weight, 20 lbs. See our 30-Day Trial Offer

A5205—Complete, set of 4, for all Ford cars prior to 1924 models 5.95

A5204—Complete, set of 4, for Ford One-Ton Truck, to carry load up to 3,000 lbs. Shipping weight, 70 lbs. 13.65

\$5.65

Set

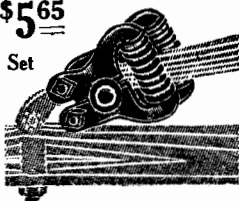

WX Shock Absorbers For All Ford Cars

WX Cushion Shock Absorbers are one of the strongest and most substantial on the market. They are steel built and unbreakable. The two-compression coil spring construction adds 100% to

the flexibility of the springs on the car. The scissor action of the shock absorbers permits them to respond readily to any downward stress under a light or heavy load automatically; also prevents any recoil or side sway of the regular spring. Will not squeak or rattle. Stop on the lever prevents regular springs from touching the axle.

These shock absorbers are being extensively used on all model Ford cars and are especially desirable for use on closed cars or cars with truck bodies.

Quickly and easily put on; only a wrench is necessary. Shipping weight, 15 lbs.

A5214—For all Model Fords—Set of 4 5.65

Rebound Check Springs

Stop the upthrow, prevent breaking springs, control the excessive spring action when cars traveling over rough roads, and in many ways improve the riding qualities of the car, taking up vibration and adding to comfort of the passengers.

Pair contains two steel clamps, two oil-tempered springs, and two strong heavy straps. Made for rear of Ford cars only. Shipping weight, 5 lbs.

A5217—Set of 2 1.50



SHOCK ABSORBER PARTS

For any make Double Arm Shock Absorbers.

- A5223—Small spring for double arm type. Wt. 8 oz. 1.25**
- A5224—Rear cross links, for double arm type. Wt. 4 lb. 1.25**
- A5227—Front arm assembly, each. Wt. 1 3/4 lb. 1.35**
- A5228—Rear arm assembly, each. Wt. 2 1/2 lbs. 1.50**

30 DAY TRIAL ON ANY SHOCK ABSORBER SHOWN ON THIS PAGE. TRY A FULL SET ON YOUR CAR FOR 30 DAYS—YOUR MONEY BACK IF NOT SATISFACTORY.

Automobile Lamp Bulbs

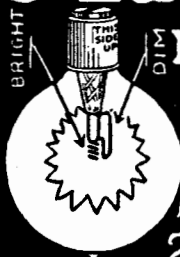

Double Bulb
for
1920-24 FORDS
With Starters
29¢ Each

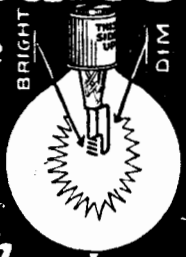

Standard quality and correct voltage. Manufactured under Edison licensed patents. Carefully packed. Shipping weight, each 4 oz.; box of 10, 1 lb.

HEAD LAMP AND SPOTLIGHT BULBS.

No.	Volts	Candle Power	Contact	Price, Each	Price, Box of 10
E6561	6-8	21	Single	.22	2.08
E6562	6-8	*21	Double	.22	2.08
E6565	12-16	21	Single	.22	2.08
E6566	12-16	21	Double	.22	2.08
E6570	9	*21	Double	.22	2.08
E6572	9	*27	Double	.22	2.08
E6574	18-24	*27	Double	.22	2.08

* For Ford Cars using regular magneto lighting.

TAIL, DASH, AND SIDELIGHT BULBS

No.	Volts	Candle Power	Contact	Price, Each	Price, Box of 10
E6577	6-8	2	Single	.16	1.33
E6578	6-8	2	Double	.16	1.33
E6579	6-8	4	Single	.16	1.33
E6580	6-8	4	Double	.16	1.33
E6581	12-16	2	Single	.16	1.33
E6582	12-16	2	Double	.16	1.33
E6586	18-24	*2	Double	.21	1.83

** For Ford Battery Bulbs, see foot of page.

Genuine Edison Mazda Double Power Bulbs

The Best Bulb made is the Cheapest Bulb to Use

Edison Mazda bulbs are the world's standard, embodying the latest scientific improvements in bulb construction. The filament is of drawn tungsten wire, closely coiled to permit a better focus, and is surrounded by nitrogen gas under pressure to resist disintegration. They burn at an average of 1/2 watt per candle power, and give an intense white light.

Experiments show that Edison Mazda bulbs will give you twice as much light on the same current, as well as being stronger and standing better an overload of voltage than the ordinary type of bulb. It pays to use the best bulbs you can get.

Edison Mazda bulbs are carefully packed and will be sent anywhere prepaid at the prices shown below.

HEADLIGHT BULBS

No.	Volts	Candle Power	Contact	Price, Each	Price, Box of 10
C5682	6-8	21	Single	.32	2.45
C5681	6-8	21	Double	.32	2.45
C5685	6-8	32	Single	.32	2.45
C5907	6-8	32	Double	.32	2.45
C5910	12-16	21	Single	.40	3.00
C5684	12-16	21	Double	.40	3.00
C5919	12-16	32	Single	.60	4.20
C5918	12-16	32	Double	.60	4.20
C5686	9	*21	Double	.35	2.70
C5680	9	*27	Double	.40	3.00
C5683	18-24	*27	Double	.60	4.20

C5906—Double Filament for 1921-24 Ford using battery

* For Ford cars using regular magneto lighting.

TAIL, DASH AND SIDE LIGHT BULBS

No.	Volts	Candle Power	Contact	Price, Each	Price, Box of 10
C5693	3-4	2	Single	.20	1.40
C5692	3-4	2	Double	.20	1.40
C5689	6-8	2	Single	.20	1.40
C5912	6-8	2	Double	.20	1.40
C5913	6-8	4	Single	.20	1.40
C5914	6-8	4	Double	.20	1.40
C5915	12-16	2	Single	.20	1.40
C5688	12-16	2	Double	.20	1.40
C5917	12-16	4	Single	.20	1.40
C5916	12-16	4	Double	.20	1.40
C5691	18-24	*2	Double	.30	2.30

* For Ford cars using regular magneto lighting.

If you do not know the size and style bulb your car uses, send in your order, giving year and model of your car, and we will send you the proper contact, voltage, and candle power for your car. You can save money by buying Bulbs in full packages of 10 and be sure of always having Bulbs when needed.

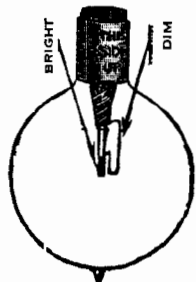

Double Filament Bulbs

For 1921-24 Ford Cars With Battery Lighting

Same as standard equipment on latest Ford cars. Has one 3-c. p. filament for dim lights and one 21-c. p. for bright lights. Size 8-11, 6-8 volt. Ship. wt., 4 oz.; box of ten, 1 lb.

E6586—6-8-volt, 21-3 c. p., each	.29
Box of 10, per box	2.78
E6587—Extra bright double-filament bulb, 6-8-volt, 32-10 c. p., each	.39
Box of 10, per box	3.65

"Daylight" Blue Bulbs

A very popular type of bulb, because it throws a clear white light without a particle of glare. Lets you use plain glass in your headlights, so as to get the best possible driving light, yet conform with all requirements of non-glare laws. A trial will surprise you.



No.	Volt	C. P.	Contact	Each
E6583	6-8	21	Single	.46
E6584	6-8	32	Single	.62
E6585	6-8	6-21	2-fil.	.57
E6586	12-16	32	Single	.66

Windshield Glass for Ford Cars



Heavy crystal sheet windshield glass for Ford cars. Cut proper size ready to slip into frame. Prices shown do not include frame for glass. Carefully packed in strong wood box to prevent breakage in transit. Guaranteed not to be wavy. Be sure to give year and model of your car when ordering. Shipping weight, 16 lbs. per glass. **Not mailable.**

- W8405**—Glass only, upper half, 1915-22 Touring or Roadster, 38x10. **2.70**
 - W8406**—Glass only, lower half, 1915-22 Touring or Roadster, 38x12. **2.95**
 - W8440**—Glass only, upper half, 23-24 Tour. or Rds. **2.95**
 - W8441**—Glass only, lower half, 23-24 Tour. or Rds. **2.95**
 - X8600**—Two-door Sedan W.S. Glass, upper or lower 1916-23, 37 1/4 x 9 3/4. **2.95**
 - X8601**—Coupe Windshield Glass, upper or lower, 1920-23, 37 1/4 x 9 3/4. **2.95**
 - X8611**—Windshield Glass, upper, 4-door Sedan, Tudor Sedan and 1924 Coupe, 37 1/4 x 9 3/4. **2.95**
 - X8612**—Windshield Glass, lower, 4-door Sedan, Tudor Sedan and 1924 Coupe, 37 1/4 x 9 3/4. **2.95**
- We can furnish windshield glass for Dodge, Chevrolet and Overland 4, Call or write for prices.**

Window Glass for Ford Closed Cars

Best quality crystal sheet glass, suitably cut and ground to fit Ford car windows as listed. Average ship. wt., 16 lbs. **Unmailable.**

- FOR FORD 2-DOOR SEDAN, 1916-23**
- X8614**—2-door Sedan front side window, 1916-21. **3.65**
- X8615**—2-door Sedan front side window, 1922-23. **3.65**
- X8602**—2-door Sedan door glass, 1915-21. **3.65**
- X8603**—2-door Sedan door glass, 1922-23. **3.65**
- X8604**—2-door Sedan rear side window, 1916-21. **3.65**
- X8605**—2-door Sedan rear side window, 1922-23. **3.65**
- FOR FORD 4-DOOR SEDAN**
- 4-door Sedan front door glass. **3.65**
- 4-door Sedan rear door glass. **3.65**
- 4-door Sedan window glass. **3.65**
- FOR FORD COUPE**
- X8606**—Coupe door glass, 1919-21. **3.65**
- X8607**—Coupe door glass, 1922-23. **3.65**
- X8640**—Coupe door glass, 1924. **3.65**
- X8608**—Coupe window glass, 1920-21. **3.65**
- X8609**—Coupe window glass, 1922-23. **3.65**
- X8641**—Coupe window glass, 1924. **3.65**
- FOR FORD TUDOR SEDAN, 1924**
- X8644**—Tudor Sedan door glass. **3.95**
- X8645**—Tudor Sedan window glass. **4.58**

Prices on other glasses for Ford cars furnished on request. **We can save you money.**

Windshield Weather Strip



F6723



F6720

A rubber strip designed to fit on top edge of lower glass of shield. Keeps out the wind and rain. Extra quality rubber; will last a lifetime.

- F6720 fits all Ford open cars, 1909 to 1922, with overlapping upper windshield. F6723 fits all other model Fords and all large cars. Ship. wt., 12 oz.
- F6720—For Ford open cars, 1909-22, each. **.37**
- F6723—For any other car, each. **.42**

Windshield Water-Shed



An absolute necessity for motorists. A light application on the glass front of your windshield will keep it absolutely clear during the rainiest or snowiest weather. The water slides from glass; cannot even become misty. One application will hold good several hours. Shipping weight, 8 oz.

G6915—Our Reduced Price, Per Can. **.17**

Adjustable Rain-Vision Windshield

For 1915 to 1924 Ford Cars

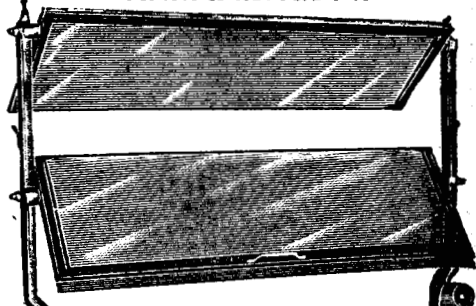

The latest and most improved type. Comes complete with brackets and crossbar assembled; crossbar is fitted with rubber filler strip which comes in contact with the lower frame when closed, making an absolutely waterproof shield. Can be attached without drilling holes in body or marring in any way. Side members are made of extra heavy steel.

Adds greatly to the appearance, convenience and comfort of your car. Metal parts are rich black enamel, fitted with best heavy plate glass. Comes well crated, no danger of breakage. Shipping weight, 50 lbs. Give year and model of your car. **Not mailable.**

- X8552**—Complete with brackets for side lamps. **13.65**
- X8553**—Without brackets for side lamps. **13.65**
- X8559**—For 1923-24 Fords with inclined windshield, (no side lamp brackets). **13.65**

“Superior” Windshield Wings

FOR ALL CARS



A distinctive-looking serviceable windshield wing at a popular price. Made of heavy plate glass with full 3/4-inch bevel on ends and outside edge. Nickel-plated brackets with suction rubber grips to hold the glass securely in place—no holes in glass to cause breakage. Brackets designed so wings can be swung inside of car entirely out of way when side curtains are used. Size of glass about 9 1/2 x 18 inches. Come complete with clamps, ready to put on. Ship. wt., pair, 15 lbs.

X8534—Windshield Wings, as illustrated, per pair **6.95**

Felt Strip for Packing Glass

A substantial felt strip, 1 inch wide, for use around windshield or closed car glass to prevent rattling and breakage.

J7844—Per foot (wt., 2 oz.) **3c**



Channel, and Tee Rubber

FOR WINDSHIELDS



Tee Rubber is used at bottom of ventilating windshields.

Channel rubber is for packing glass in frame and prevents rattling. Ship. wt., 4 oz. per ft.

- F6726—Tee Rubber, 1 1/2" wide, 42" length, each. **.40**
- F6719—Channel Rubber, per foot. **.7c**

Glare Shield

A real necessity for every motorist, by day or night. Protects against the glare of approaching headlights, as well as that of snow or sun. Made of heavy colored celluloid, size 5x7 inches, substantially mounted in metal holder, which clamps on top or side of windshield. Easy to move or remove.



A5112—Each (Shipping weight, 8 oz.) **.34**

Automatic Windshield Cleaner
FOR COMFORT AND SAFETY

Lets you drive through rain or snow with the same clear view of the road as on the finest summer day.



Works from the intake vacuum, so that the suction of the motor keeps it going as long as your engine runs. Turned on and off by a button within easy reach of the driver. Wiping arm locks back out of the way when not in use. Black enamel finish—an ornament to the car. Easily installed by anyone; full instructions furnished. No upkeep cost, no adjustments, no attention needed. Don't take chances on a serious accident to yourself or others, when you can get this dependable cleaner at our low reduced price. Ship. wt., 3 lbs. **A5081—Automatic Cleaner, complete. 2.95**

Security Windshield Wiper

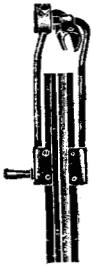

Can be clamped to top or side of windshield frame on open cars, or inserted through hole in frame on closed cars. Wiping bar of flexible rubber outside the glass with felt inside the glass, cleans both sides at once, and can be raised or lowered to suit driver's line of vision. Has nickel-plated handle, easy to get hold of. Finished in black enamel. Strong, neat, durable. Shipping weight, 1 1/4 lbs.

A5133—Our Reduced Price.65

Auto-Felt Windshield Wiper

Every day you drive in stormy weather without a windshield cleaner on your car you are taking chances of wrecking your car and risking your own life and the lives of others.

Auto-Felt is one of the most satisfactory windshield wipers ever offered. Has twin pads of chemically treated felt for both sides of the glass, outer pad being reinforced with rubber strip. The chemical felt pads treat the surface and prevent gathering of rain, mist, and damp snow. No continual wipe, or movement back and forth to distract the driver's attention. Convenient to handle. Will fit any car. Absolutely guaranteed.

F6728—Auto-Felt wiper (ship. wt., 1 1/4 lbs.) 1.38



Jiffy Windshield Cleaner

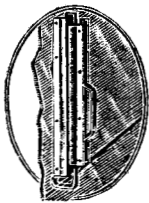

Slips on upper windshield glass between the halves, and cleans both sides of the glass at the same time. Will fit any two-piece windshield, straight or overlapping, on either open or closed cars, even when equipped with weatherstrip. Made of highly polished aluminum, with four strips of select quality rubber, tempered steel spring to hold firmly on glass. Will not rattle. Convenient handle for operating. Shipping weight, 1 lb.

A5086—Our Reduced Price, complete.78

Handy Windshield Cleaner

A very handy article for cleaning windshield preventing rain or fog from obstructing your vision. Made of small steel rod with two-ed rubber wiper, which cleans glass very effectively. Fits almost any shield. Shipping weight, 1 lb.



F6725—Our Reduced Price 35

“Peerless” Green Pyralin Visor
For Open or Closed Cars.

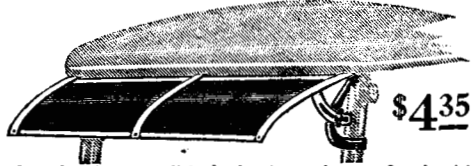

Has handsome polished aluminum frame, fitted with panes of heavy transparent DuPont Pyralin or celluloid of the popular green shade. Much lighter and neater than glass, without the liability of breakage. Note substantial side brace. Has graceful, attractive curved lines—a handsome ornament for any car. An exceptional value, as similar visors are sold at about double our price. Easy to install; comes packed in substantial box, complete with clamps and full instructions; a screw-driver is the only tool needed. **In ordering, be sure to specify make, and year of car, and whether open or closed.**

X8755—Complete for any car except Ford open cars prior to 1923 (ship. wt., 6 lbs.) 4.35
X8791—Genuine Premier Visor, blue pyralin with black satin enamel frame (not illustrated) 5.35

All-Metal Visor
For Open or Closed Cars

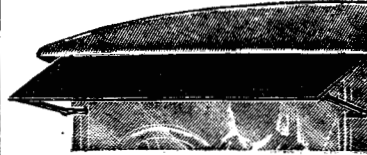

\$2.68

Made entirely of metal, electrically welded. Front and back edges are rolled into

gutters which keeps the rain from blowing back on windshield. Outside finished in beautiful black enamel, baked on and under side in green enamel which eliminates reflection and distracts the eyes. Universal brackets adjustable to any angle. Easily attached and practically indestructible. Comes complete with all necessary fittings and screws for attaching. Shipping weight, 7 lbs. **In ordering be sure to give make, year and style of car.**

X8539 —For any car except Ford open models prior to 1923. 2.68

“Protector” Leatheroid Visor
For Open or Closed Cars.

2.18

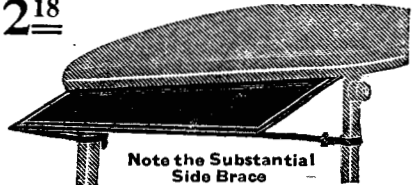

Note the Substantial Side Brace

Consists of a frame made of strong steel rods, neatly covered with dark artificial leather. Special brackets permit easy adjustment by simply loosening two wing nuts and when adjusted the visor will not rattle or come loose. Can be put on by anyone in a few minutes; a screw-driver being the only tool needed. Will fit any open or closed car, **except Ford open models prior to 1923. State make, year and style of car.**

W8404—Visor, complete. (ship. wt., 6 lbs.) 2.18

Leatheroid Visor—For All Cars
Will Fit 1909-22 Ford Open Cars

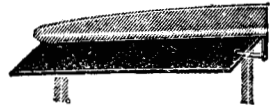

Note substantial adjustable Bracket

Very similar to W8404 above, except that it does not have the side braces on windshield. Attaches to under side of top or front bow, so that it will fit practically any car made, including all open model Fords. Easily and quickly attached, and readily adjusted to any angle desired at any time. A durable visor, strong and substantial. Ship. wt., 6 lbs.

W8403—Visor, complete. 1.68

"The Dandy" Spotlight



Complete \$2.65

One of the most up-to-date and attractive spotlights ever made. Instead of being big, heavy and cumbersome they are small and neat and give your car that snappy, classy appearance. Will give more light than the average large spotlight and is ideal for night driving as light from it may

be thrown to the right or left and thus show objects which light from the headlights would not reach. Lens size 4 1/2 inches, lamp all brass with best quality reflector. Has switch in socket and comes complete with wire. Furnished in black with nickel rim or all nickel. Ship. wt., 2 lbs.
A5173—Black with nickel rim, complete..... 2.65
A5174—All nickel, complete..... 3.65
A5177—Extra Lens for "Dandy" Spotlight (4 1/2")..... .25

Prices shown above include 6-volt bulb. Furnished with 12-volt or 18-volt bulb for 15c extra.

Anderson Auto Reelite and Trouble Lamp
 THE SPOTLIGHT ON A REEL

This new lamp really contains three light in one—a spotlight, a trouble lamp and portable lamp. Has a patented reel with plural springs, and 12 feet of cord, that works on the same principle as a window shade on its roller. This permits of many practical uses, as the light can be easily carried right to the spot where it is needed. Makes an excellent lamp for camping and touring.

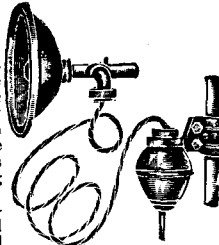

This is the popular thin model, light and durable. Neat and attractive in appearance. Shell made of one-piece brass, beautifully black baked enameled and nickel finished. Lens 6 inches in diameter. Convenient switch. A convex reflector throws a powerful straight beam of light a great distance to any point. Bracket holds lamp securely in any position; will not shake loose or rattle. Comes complete with bulb, brackets and fittings ready to attach to any car. Shipping weight about 4 lbs.

C5852—Complete with 6 volt, 21 C.P. bulb..... 6.95
C5853—Extra Lens for Auto-Reelite (5 1/2")..... .28

Drum Spotlights

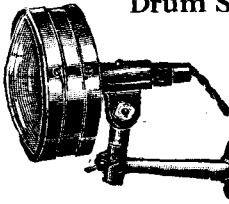

Lamp, including bracket, is made entirely of brass, and positively will not rust or corrode. Supplied in two finishes, all nickel or black and nickel, the latter having black body and bracket with nickel-plated rims both front and rear. Comes complete with five feet of wire. Switch contained in lamp. Throws a strong, bright light and improves appearance of car. Size of lens, 4 1/2 inches. Ship. wt., 4 lbs.

E6397—Black and nickel, 6-volt..... 4.45
E6398—All nickel, 6-volt..... 5.35

Sure-Fit Windshield Wings

High quality glass windshield wings, size 6x16 inches. Edges of glass are protected by a frame of rust-proof metal with nickel finish. All attachments made of steel, heavily nickel-plated over copper. Quickly adjustable at any angle.

Will fit any two-piece windshield. Easily installed—no drilling necessary. Does not mar the car or interfere with use of side curtains. Adds to appearance and comfort, by protecting occupants from dust and draught.

X8742—Pair, complete (ship. wt., 8 lbs.) 1.95

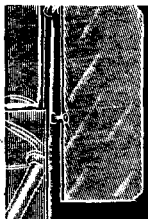

"Safety" Spotlight

An exceptional spotlight value. 4 1/2 inch convex lens. Body finished in black enamel, with nickel rim. Highly polished reflector. Long handle with enclosed switch. Good strong bracket; light can be turned at any angle. Complete with bulb and wire for attaching. Shipping weight, 3 lbs.



\$1.58

C5812—Safety Spotlight, 6-volt bulb..... 1.58
 Same spotlight equipped with 12-volt bulb, or with 18-volt bulb for use with Ford magneto, 15c extra.

A5177—Extra Lens for Safety Spotlight. (4 1/2")..... .25

"White-Way" Spotlight
 THE POPULAR THIN MODEL

\$2.95

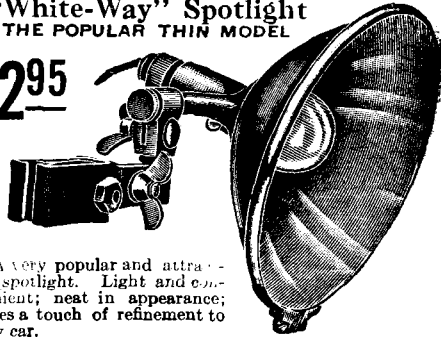

A very popular and attractive spotlight. Light and convenient; neat in appearance; gives a touch of refinement to any car.

Made of solid one-piece shell, 6 inches in diameter. A strong, substantial, convenient bracket holds the lamp in any position desired. Will not shake loose or rattle. Convenient switch. The special shaped convex reflector throws a straight, clear white beam of light a great distance in any direction. Beautifully finished in best baked black enamel. Comes complete with all necessary brackets, fittings, bulb and wiring ready for use. Easy to attach to any type wind shield. Shipping weight, 3 1/2 lbs.

C5854—Complete with 6-volt bulb..... 2.95
 Same spotlight equipped with 12-volt bulb, or with 18-volt bulb for use with Ford magneto, 15c extra.

C5856—Extra Lens for C5854 and C5855 (6")..... .28

Spotlight and Mirror Bracket
 FOR ALL CLOSED CARS



A handy device which fastens to the wood frame at the end of the windshield on closed cars and makes a substantial bracket for attaching spotlights and mirrors. Made of brass, black enameled. Improves the appearance of car and becomes permanent part of it. Shipping weight, 4 oz.

C5859—Our Reduced Price..... .28

Through-the-Glass Spotlight

The most practical and satisfactory type of spotlight, especially for closed cars. Can be installed through any part of the windshield most convenient for the driver to reach. Has friction ball joint, so that it absolutely stays put in any position. Made of high grade materials, with silvered reflector. Finished in black enamel with nickel-plated rim. Black composition handle. Diameter of lens, 4 1/2 in. Length of spotlight over all, 7 in. Ship. wt., 3 lbs.

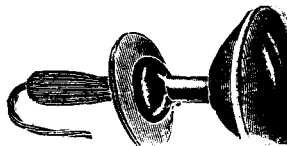

C5849—Through-the-Glass Spotlight, complete. 4.95

A5177—Extra lens for..... .25

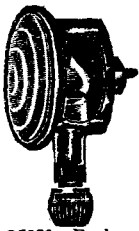

**Electric Tail Lamps
FOR ALL CARS**

These are standard size 3" black enamel lamps with red glass in rear and clear light on side to show on license. Complete with bulb and connector. Wt., 2 lbs.

- C5833—For 1915 to 1922 Fords 6-volt, double contact bulb .48
- C5834—For 1915 to 1922, Fords, 6-volt single contact bulb .48
- C5831—For 1915 to 1923 Fords with 18-24 volt bulb for magneto use. .60
- C5830—For large cars. Has 2 bolts in back of lamp for attaching. Bolt centers adjustable from 1 1/2 to 2 in. apart. 6 volt, single contact. .58
- C5832—For large cars and trucks. Has square bracket on back to slip down over rod or iron strip. 6 volt, D. C. bulb. .55

Safety Tail-Light Lens



Gives warning even when bulb burns out, by reflecting a red light from the headlights of the car behind. Simply replaces the regular 3-inch tail-light lens, and works with a bulb like any other lens. But if the bulb burns out, it will show up red when the lights of a car behind are 100 to 200 feet away. Used and endorsed by the police departments of many cities. Every car should have one. Shipping weight, 8 oz.

- Our Reduced Price
- D6272—For any tail-light using 3-inch lens. .49

Security Stop Light

**FOR TAIL LIGHT
OR FENDER**

A well-made, attractive stop signal, furnished with two sets of brackets, so it can be mounted on the tail-light as shown in illustration, or mounted on rear fender like ordinary signal. Comes complete with substantial switch, and all necessary wire and fittings, as well as full instructions. Ship. wt., 3 lbs.

- C5845—Stop-light, complete 1.68



**Drum Head Lamps
for Popular Cars**

Here is without doubt the most beautiful and "classiest" head lamp ever designed. Same style and shape as the lamp now being used as standard equipment on some of the highest priced cars on the market. E6392 and E6399 are equipped with special bracket for attaching to any Ford cars since 1915 and are adjustable for throwing light up or down. Reflector is parabola-shaped, highly polished. Furnished either with black body and two nickel-plated rims, or all black except front rim nickel-plated. All lamps complete with bulb and dimmer lens. Sold only in pairs. Ship. wt., 12 lbs.

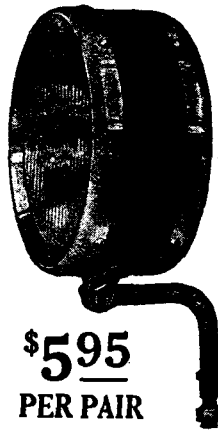

**\$5.95
PER PAIR**

- E6399—Per pair, for Ford, black with one nickel rim. . 5.95
 - E6392—For Ford, black body, two nickel rims, pr. 6.55
 - E6394—Universal type for attaching to fenders. Will fit Chevrolet prior to 1923, Peerless, Oldsmobile, Liberty, Hupmobile, Oakland, Paige, Overland, Nash, Saxon, and Case. Black body with two nickel rims, pr. 8.25
 - E6395—Special for Dodge, Jordan and Westcott, black body with two nickel rims, per pair. . 7.85
 - E6400—Bolt-on type for attaching to fenders or crossbars. Fit Chevrolet 1923-24, Dorr since 1922, Durant, Essex, Star, Hudson since Model O, Chandler since 1922, Maxwell, Moon, Gardner, Reo since 1922, Studebaker Light 6, Chalmers since 1922, Willys-Knight since 1922. 7.20
- All lamps listed above have 9" rims. For any car shown, except Ford, we can furnish larger lamps, with 10" rims, for \$11.25 per pair. Ship. wt., 14 lbs.
- E6386—9" rim only, for drum headlamp (1 lb.). 78

Reflector Polish

The light thrown by an automobile lamp or spotlight depends largely on the finish of the reflector. You cannot expect to have a good driving light unless your reflectors are kept highly polished. Our reflector polish is made especially for this purpose. It will remove finger marks, and all dull spots, and produces a mirror-like surface. Absolutely guaranteed not to scratch and to give perfect satisfaction.



- C5883—Per Can—(Ship. wt., 8 oz.) 25

**Lamp Doors, Reflectors
and Parts**

FOR FORD CARS

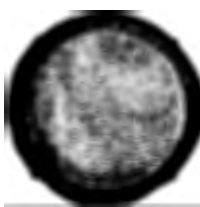

- C5898—Electric Headlamp Door without Glass, (wt. 1 lb.), ea .29
- C5890—Headlamp Lens, plain glass 8 1/2 in. (1 lb.) each .14
- C5895—Electric Headlamp Reflector, (Wt. 1 lb.) each. 49
- C5888—Reflector cord (to prevent rattling) per foot. 3c
- C5886—Red Tail Lamp Lens. Celluloid—3 1/2" easily cut down, if necessary, to fit any size tail lamp. 9c
- C5887—Electric Tail Lamp Retainer Ring. Fits any 3" lamp. 5c

Nickel-Plated Lamp Door



For All Model Ford Cars

Made from steel, nickel-plated and highly polished. Fits any Ford headlamp and adds greatly to appearance of car. Ship. wt., each, 1 lb.

- C5901—Each, Rim only, no lens. 48

HEAD LAMP OUTFITS for Ford Cars

COMPLETE WITH BULBS AND DIMMER LENS

This outfit consists of two high grade 9-inch Torpedo Electric Headlights, made of pressed steel black enamel fitted with scientifically correct parabolic triple plated silver reflectors, with focusing device and genuine Tungsten bulbs. They will use the current from either the Ford magneto or from a storage battery.

These lamps make a very brilliant light; beautiful, distinctive and attractive adding a great deal to the appearance of your car. C5836 lamps are for 1909-1914 Ford cars, with brackets on sides, while C5840 and C5843 have upright brackets as shown in illustration. Shipping weight per pair, 10 lbs.



**\$3.95
Set**

- C5840—Pair, for 1915-20 cars (9-volt, double contact bulbs) 3.95
- C5843—Pair, for 1921-24 cars, with Tuliite double filament bulbs 3.95
- C5836—Pair, for 1909-14, complete with wiring assembly (not shown) 4.95

BRITE-LITE

EQUALIZER
REGULATOR AND INTENSIFIER



200% More Light



"Brite-Lite" Equalizer. Dimmer Switch.

FOR FORD CARS WITH MAGNETO LIGHTING ONLY

Gives 200% more light at slow engine speed and prevents burning out bulbs at high speed.

Every Ford car with magneto lighting needs this attachment. You would not be without it after you try it. A Ford equipped with our "Brite-Lite" has practically as much light at 10 miles per hour as without it at 20. The engine can be throttled down moderately slow, yet it gives a full clear driving light. It acts as a "booster" at slow speed and at extremely high speed it works as an automatic check coil which prevents excess current from burning out the bulbs. You use the regular Ford bulbs. It needs no attention

or regulating, and is easily installed by anyone. The device cannot injure any part of your car or affect ignition in the least. "Brite-Lite" is fully guaranteed, and if for any reason you are not satisfied we agree to refund the price. Full instructions are furnished. Order one today, try it 30 days at our risk, and you will be greatly surprised that your lights could be so wonderfully improved. Made in two types, the "straight type" for 1915-17 Fords or any other Ford with switch on dash, and the "dimmer type" for 1915-24 Fords (with magneto lighting only), which provides also a dimming convenience. Ship. wt., 2 lbs.

C5765—Straight Type "Brite-Lite," complete... **1.25**

C5766—Dimmer Type; can be used on any model and required on all Fords having a dimmer switch, complete... **1.95**

Safety Light Plug

Instantly Changes Your Light From That Foggy Reddish Tint to a Clear White Light.



Merely remove the old plug from the right-hand side of your car and insert a Safety Light Plug in the back of your lamp, then put the old plug in the socket of the new one. That is all you have to do. Anyone can do it in a minute's time. The plug is absolutely guaranteed, too, for the full life of your car. Nothing to wear out or get out of order. Should either light become defective, the plug will enable the other light to retain its brilliancy. Money back if not satisfactory. For Ford cars with magneto lighting only. Weight, 10 oz.

C5760—Our Reduced Price... **.28**

Electric Parking Lamp

You should use a parking lamp, instead of burning both front and rear lamps when parking. Save your battery current and comply with the law. A very attractively designed electric lamp, with both red and white etched oval dome lens. Comes complete with 6 volt, 2-C.P. double contact bulb and handy on and off switch. Throws a clear, white light ahead and a red light behind. Can be attached to left rear fender with bolts furnished and wired to battery or dry cells. Makes an excellent emergency tail lamp. Can be used on any make car. Lamp is 2 1/2 inches high, with lens 1 1/2 inches in diameter. Has beautifully nickel-plated finish. A pair of these lamps make novel and very attractive sidelamps for speedster.



C5810—Each, complete. (Ship wt., 1 lb.)..... **.78**

Electric Dome Lamp

FOR ALL CLOSED CARS

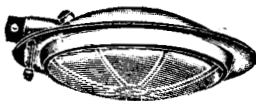

A new and popular pattern. Well made, nicely finished rim. Beautifully etched glass. Convenient and useful lamp for all closed cars. Diameter of lens, 2 1/4". Burns ordinary 2-C.P. tail light bulb. Near in appearance and adds a touch of refinement to any car. Made with convenient switch for turning on or off. Can be used with any 6-volt lighting system. Ship. wt., 1 1/2 lbs.

C5796—Our Reduced Price..... **1.48**

Tiffany Parking Lamp



Has a fine nickel plated case with clear lens in front, ruby lens in rear and green lens on side, thus giving complete parking protection. Fits snugly against fender and gives the appearance of being part of the car. Lamp is 2 inches high, length over all 2 3/4 inches. Comes with 6-volt bulb. Ship. wt. 8 oz.

C5811—Each... **1.28**

Electric Side Lamps FOR FORD OPEN CARS

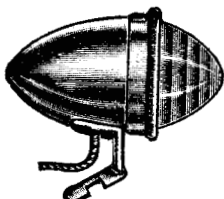

An attractive, well-made side lamp, especially designed to fit Ford roadsters and touring cars 1920-24. Attaches by loosening one bolt that supports the windshield, then slipping bracket of lamp on bolt and tightening. Bracket is bent so that lights point straight ahead. Complete with 6-volt bulb. Ship. wt., pair, 2 lbs.

D6185—Black body with nickel rim, pair..... **3.35**

Drum Side Lamps for All Cars

Designed to match the drum type headlights, which are now so popular. Will fit on side of cowl of practically any car. Lamp is 3 inches high, with frosted lens 2 1/2 inches in diameter. Come complete with 6-volt 2-C.P. bulb. Easily installed. Make an attractive ornament, besides saving the battery when driving on lighted streets. Ship. wt., pr., 2 lbs.

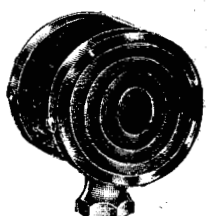

C5844—Black, with two nickel rims, per pair.... **2.15**

McKee Spreadlight Lens



An unusually fine moderate priced lens, that gives a good light for driving, and is guaranteed to meet legal requirements in any state of the Union. Used as factory equipment on Hudson, Essex, Columbia, Hupmobile, Chalmers, Maxwell and other well-known cars. Good heavy, substantial glass. Average shipping weight per pair, 3½ lbs.

C5921—Special for Ford, per pair	..	.49
C5932—7¼-in., (for Chevrolet Superior), pair	..	.97
C5922—8-in., pair	..	.97
C5923—8¼-in., pair	..	.97
C5924—8¾-in., pair	..	.97
C5925—8½-in., pair	..	.97
C5926—8¾-in., pair	..	.97
C5927—8¼-in., pair	..	.97
C5928—9-in., pair	..	.97
C5929—9¼-in., pair	..	.97
C5930—9½-in., pair	..	.97
C5931—9¾-in., pair	..	.97

McKee Standard Lens

Gives Better Light—Complies With Law

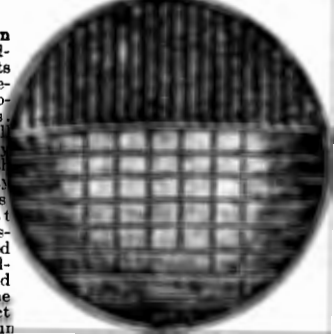

This well known scientific Headlight Lens meets every requirement of an automobile lens. Eliminates all glare, thereby complying with state and city no-glare laws. Made of best heavy glass. Especially designed to avoid headlight glare and at the same time not to detract from the volume of projection light. This lens gives a good driving light at all sides, as well as lighting the road ahead as much as six hundred feet. Thousands of these lenses now in daily use on all makes of cars everywhere. Strong, durable and neat in appearance. Come carefully packed. Furnished for all standard makes of cars. To make sure of getting exact size, take out the glass from one of your lenses, lay it on a piece of paper and mark around it with a pencil. Then attach the paper to your order. Average shipping weight, 4 lbs.

REPLACEMENT LENS For Ford Cars

This is an exact match for lens furnished with all late model Ford cars. Complies with all state laws and gives more light than plain lens. Furnished for Ford cars only. Shipping weight, per pair, 3 lbs. **Our Reduced Price** E6556—Each, **.20** Per pair, **.38**



Stop Light Switch



The switch is the most vital part of a stoplight, and there are a great many unsatisfactory ones on the market. We have tested this switch and found it far superior to any we have ever seen. Made

entirely of brass, even the spring. We recommend it for quality and service. Ship. wt., 8 oz. **Our Reduced Price** D6227—Extra switch for stoplight, **.30**

Slow—Stop—Parking Light

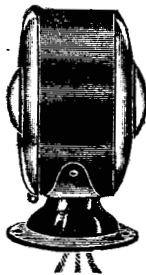

The ordinary stop signal is misleading because it shows "Stop" whenever you step on the brake, whether you are going to stop or not. This new light shows "Slow" in green whenever you step on the clutch or brake, then when you push the brake pedal all the way down it flashes "Stop". Absolutely automatic and no guessing on the part of the driver behind. Also adapted for use as parking light, with clear lens in front and ruby lens in rear, with separate switch furnished for installing on dash. A substantial, attractive lamp, well finished in black enamel. A high grade switch, guaranteed to be trouble-proof. Light is 6 in. high, lens 4½ in. in diameter, parking lenses 1¾ in. Ship. wt., 6 lbs. **Our Reduced Price** D6204—Slow-Stop-Parking Light, with instructions **3.35**

	Our Reduced Price
C5861—7¾", per pair	1.60
C5860—8", per pair	1.62
C5863—8¼", per pair	1.65
C5864—8¾", per pair	1.68
C5865—8½", per pair	1.69
C5866—8¾", per pair	1.95
C5868—8¼", per pair	1.98
C5869—9", per pair	1.98
C5870—9¼", per pair	1.98
C5871—9½", per pair	1.98
C5872—9¾", per pair	1.98

McKee Lens for Ford Cars



Same lens as described above, but made up to fit any model Ford. The square projections fit the new style headlamp doors, while the diameter of the round portion of the lens is just right for the older style. Throws a good light and does not glare.

Shipping weight, 3½ lbs.

	Our Reduced Price
C5862—McKee Lens for all Ford cars, per pair	.89

Automatic Stop Signal

Here is the latest device for protection from the "man behind you." Special switch attaches to brake rod of any car, and when the brake is applied, a light burns in the signal and the word "Stop" flashes before the approaching car. Many states have passed laws requiring the use of a signal of this kind on all closed cars. Its use may save a big repair bill caused by the carelessness of some driver behind you. Comes complete with switch wire, and full instructions, and can be put on by anyone in a few minutes.



Shipping weight, 4 lbs.	
D6225—Signal complete	1.19
D6226—Extra Lens for Stoplight	.35

"Short-Proof" Timer Wire Assembly

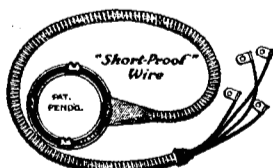

Timer wires are always exposed to oil and water, so that the insulation soon rots through and you get a "short," causing the motor to miss, "kick back," and even back-fire. The Short-Proof Wire avoids this trouble by enclosing timer wires in a flexible metal cable, ending in a fiber disc sealed in a metal case that slips around the timer shell. Delivers 100 per cent of your current to your spark-plugs; makes motor run smoother and start easier; saves gas and oil. Eliminates 75 per cent of ignition trouble, and prevents broken arms and starter springs from "kicking back." Easily installed; should last life of car. Money back in 30 days if not satisfied. Shipping weight, 2 lbs.

C5584—Complete with instructions. 1.35

Wiring Assemblies for Ford Cars with Starters

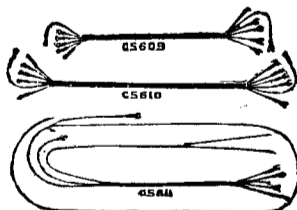

Full length wiring assemblies to replace those on Ford cars with starters. Each wire same color as furnished as equipment, thus making them easy to install properly. Terminals same as those on original Ford wires. For ignition wires see "Wiring Outfits" on this page. Av. ship. wt., 1 lb.

- C5609—Wire assembly (switch) for any Ford Coupe, Roadster or Touring with starter.42
- C5610—Wire assembly (switch) for any Ford Sedan.45
- C5611—Wire assembly (left head-lamp and tail-lamp) for any Ford with starter.52

Battery and Starter Cables

For Ford Cars

Replacement cables for Ford cars with starters. Made of heavy wire, well insulated, strong terminals lead coated to prevent corrosion.

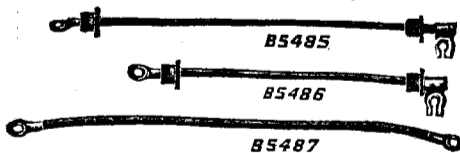

- B5485—Complete for Ford (battery to foot switch) Wt. 2 lbs.68
- B5486—Complete for Ford. (Battery to ground). Wt. 1 lb.48
- B5487—Complete for Ford. (Foot switch to starting motor). Weight 2 lbs.45

Insulating Staples

For attaching electric wire.

- Shipping weight, per package, 4 oz.
- C5892—Package of 25.10



Wonderliter



A sure, simple, safe, dependable pocket lighter, made of substantial brass, triple nickel-plated. Just unscrew the striker, give it a quick glancing stroke across the sparking metal at the bottom of the case, and you have an ample light for campfire or smoke. A few drops of gasoline occasionally keep the Wonderliter in perfect working order. Nothing to leak or spill, no springs or wheels to get out of order. Will last indefinitely. Size, 2 1/4 x 1 1/2 x 3/4 inches.

A5032—Each (ship wt., 8 oz.)25

Try our Western Giant Cord Tires. You can pay more money but you can't buy better tires. See special prices on page 7.

Overhead Cable Sets

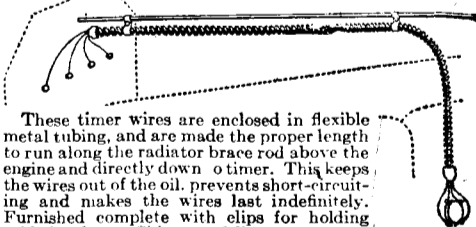

These timer wires are enclosed in flexible metal tubing, and are made the proper length to run along the radiator brace rod above the engine and directly down to timer. This keeps the wires out of the oil, prevents short-circuiting and makes the wires last indefinitely. Furnished complete with clips for holding cable in place. Ship. wt., 1 lb.

- C5621—Set, with spark plug wires.68
- C5620—Set, without spark plug wires.58

Braid Covered Wiring Outfits

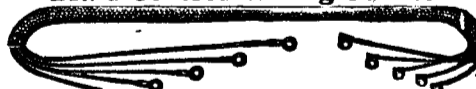

These wiring outfits are the same style and quality as those used as regular equipment on Ford cars. They are well made and equal in every respect to the original outfit. Shipping weight, 1 lb. Our Reduced Price

- C5625—For 1909 to 1922 cars (5 wire)34
- C5626—For 1919-22 cars with starters (6 wire)42
- C5627—For 1923-24 cars with starter (7 wire)52
- K8136—For Fordson Tractor.42

Magneto Wire



Made of extra heavy high tension wire with strong terminals. Proper length to reach from magneto contact on top of transmission cover up to coil box. Can also be used as spark plug wire for front cylinders. Shipping weight, 4 oz. C5630—Each.84

Spark Plug Wires For Ford



- Complete set of four wires, extra quality, braid covered. C5633—Complete Set. (Ship. wt. 8 oz.)18
- K8137—For Fordson Tractor.32

Extra Quality Friction Tape

An extra quality friction or "tire tape," for insulating wires and making emergency repairs. Closely wrapped in foil in handy carton, to keep it fresh and clean, always ready for use. Should be carried in the car at all times. Width 1/2 in.

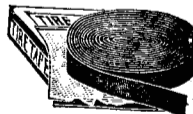

- E6350—2 oz. Roll.84
- E6351—4 oz. Roll.14
- E6352—1/2 lb. Roll.24

Extra Quality Lamp Cord



- Ship. wt., 1 lb. to 10 feet. Two-strand, twisted, braid covered. C5660—Green and yellow covered, per foot.34
- C5661—Black covered, per foot.34

Armored Lighting Cable



Primary or lighting cable, well insulated, then wrapped with half round galvanized steel armor, making it almost wear-proof and indestructible, yet very flexible. Excellent for lighting purposes on any car. Ship. wt., per foot, 8 oz. C5657—Single Strand Armored Cable, per foot.44
- C5658—Double Strand Armored Cable, per foot.60

Dash Lamps

All our dash lamps are substantially made and finished with fine nickel plating.

Straight type extends straight out from dash, 2 1/2", with bulb protected as shown. Attached without cutting dash. Switch in stem.

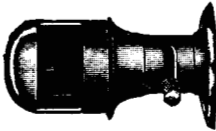

Straight Type

Cowl type fits flush in dash or cowl board and extends out only about 1 1/2". It is fine for use with speedometers or clocks which fit flush in cowl boards.

All dash lamps are furnished without bulb. You can buy bulb extra as shown below. Average shipping weight 1 lb.

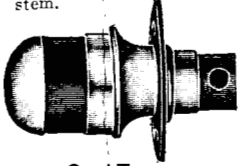

Cowl Type

- C5798—Straight Dash Lamp only (with switch) **.34**
- C5800—Cowl Wood Board Lamp Only **.30**
- C5692—3-4 V. Bulb for 3 Dry Cells **.16**
- E6578—6-8 V. Bulb for Storage Battery **.18**
- E6582—12-16 V. D. C. for Storage Battery **.18**
- E6586—18 V. Bulb for Magneto **.21**

"Universal" Dash Lamp

FOR ALL CARS WITH METAL DASH

Beautiful nickel plated dash lamp for any car with metal dash. Especially adapted for use on late model Ford cars with battery. Easily installed.

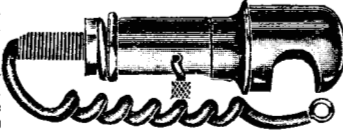

Drill hole in dash, insert shank, and tighten lock nut. Then connect the wire furnished with the lamp to the tail light binding post or the dash switch. Note small shank which makes installation easy. Has switch in stem. About 10 in. wire furnished.

- C5801—Lamp with wire, less bulb (Ship.wt., 8 oz.) . . . **.39**
- E6577—6-volt—2 c.p.s.c. bulb for above **.16**
- E6581—12-volt, 2 c.p.s.c. bulb for above **.18**

Teltaillite

Be Sure Your Stop Signal Warns

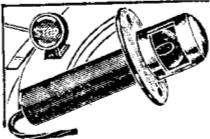



This is a pilot light, installed on dash, to be connected with the wiring of any stop signal, so that you know whether your signal is operating. Pilot light shows only when signal comes on, remains lighted while signal is lighted, and shows when signal goes out. Will prevent confusion and waste of current if stop signal does not cut

out when brake is released. Easily installed; requires no attention. For use with any 6-8 volt lighting system. Shipping weight, 8 oz.

- C5820—Complete with 3-4-volt bulb **.69**

Lighting and Ignition Cable

-  **3c foot**
-  **5c foot**
-  **6c foot**

We carry high-grade cable. The wire is covered with several layers of rubber as shown in cut, and covered outside with close woven braid. This cable is perfectly insulated, and is heat, grease, oil and moisture proof.

- | | |
|---|----------------------|
| Shipping weight, 1 lb. to 6 feet. | Price per Ft. |
| C5664—Primary Low Tension | 3c |
| C5663—Secondary High Tension | 5c |
| C5662—2-Strand Primary for lighting | 6c |

Handy Troub'e Light

Snap Type for Carrying in Tool Box

A substantial, well-finished troublelight with hinged nickel-plated reflector, which folds like a globe when not in use, and snaps together like a pocketbook, absolutely protecting the bulb from breakage. Comes complete with 6-8-volt bulb, 10 feet of cord, and plug for attaching to any light socket. Black wood handle. Length over all about 6 inches. Shipping weight, 1 lb.

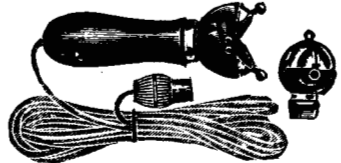

- C5785—Complete for double contact sockets **1.28**
- C5787—Complete for single contact sockets **1.38**

Combination Dash and Trouble Lamp

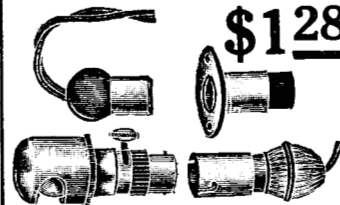

\$1.28

Has 6-volt 2-candle power tungsten bulb, Edison wood dash connector with screws and about 10 feet of extension cord, with socket on one end and connector plug at other end. On and off switch. Lamp can be removed from socket in dash and connected up for use as a trouble lamp. Nickel-plated. For use with storage battery. Shipping weight, either style, 1 lb.

- C5794—Double contact for metal dash **1.28**
- C5793—Double contact for wood dash **1.28**

Clamp-on Dash and Trouble Light

FOR FORD CARS



Meets the objections to other styles of dash lights and trouble lights that it is necessary to cut the instrument board in order to put them on. This style simply clamps on the instrument panel—no holes to drill or screws to drive. Comes complete with 10 ft. of insulated cord, fitted with plug and wood handle for use as trouble light. Ship. wt., 1 lb.—Price includes 6-volt bulb. Regular price, \$2.50.

- C5805—Complete dash and trouble lamp **1.89**
- C5804—Clamp-on dash light only **.75**

Portable Garage Lamp

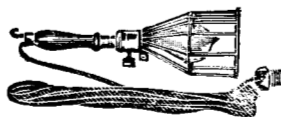

Has black enameled wood handle with brass hook on end, substantial wire guard for protecting bulb, Edison key socket, composition separable attaching plug, a 16-

C. P., 110-volt carbon bulb, and 10 feet of insulated wire. Indispensable in working around the car at night. Shipping weight, 3 lbs.

- C5592—Portable garage lamp, complete **1.95**
- C5593—Extra wire guard, guard only **.24**

Rubber Covered Ignition Cable

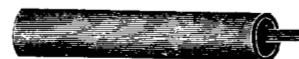

High tension or secondary cable, with thick rubber insulation, especially constructed to withstand heat and prevent short circuiting. Used as regular equipment on many cars. Shipping weight, per foot, 8'oz.

- C6589—Rubber-covered cable (about 5-16" diam.), per foot **5c**

Atwater Kent Ignition System for Ford Cars with Battery

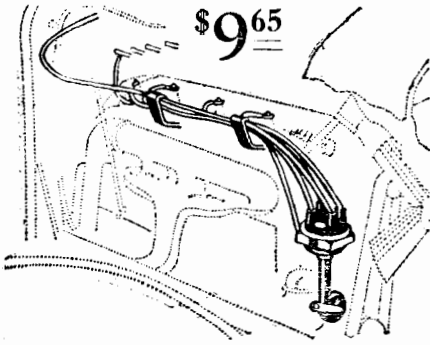

\$9.65

One of the most satisfactory ignition systems ever designed for the Ford car. It eliminates the use of the Ford Timer which has always been a source of trouble. The mechanism is all elevated, thus bringing it and the wiring up out of the oil and dirt. Eliminates all noise from the vibrators. Uses one Ford coil unit thereby saving the cost of a new coil and leaves three coils for emergency use.

Makes the motor run much more smoothly, due to increase in spark heat from battery and more accurate timing. Makes starting easier on account of hot spark at low speed. Spark is of uniform intensity for all four cylinders because the current is constant, only one coil is used, and the spark is accurately timed for each cylinder. Combines automatic spark advance with hand advance. Increases power, giving better hill-climbing, greater acceleration, and less gear-changing. Easily installed without removing radiator. Operates on current from the storage battery, using one Ford coil with vibrators screwed down tight or special closed contact coil listed below. Comes complete with all necessary wiring, fittings and instructions. Shipping weight, 8 lbs.

Our Reduced Price
K8026—Complete Ignition System 9.65

Genuine Bosch Ignition System FOR FORD CARS

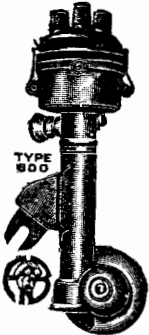

This is the well known Type "600" Bosch ignition system, designed especially for Ford cars by the engineers who built the famous Bosch magneto.

Eliminates all timer trouble, furnishing big, hot, perfectly timed sparks that fire the gas instantly and completely. Makes the engine powerful, smooth-running, flexible, so you can throttle down in traffic without "bucking," then dart ahead when you turn on the gas. The increased power of your motor will surprise you.

Has an automatic spark advance that adapts the spark to meet all engine speeds without a knock. Lets you forget the spark lever entirely.

Uses regular magneto or storage battery current with one of the regular Ford coils, or can be used with special closed contact coil like the one shown

at right. Comes complete with all necessary cables, etc. Easily installed by anyone in a short time by following instructions furnished. Shipping weight, 8 lbs.

Shipped anywhere prepaid at this price.
C5611—System complete for any model Ford 12.75

Delco Ignition System for Ford

Made by a company with a world-wide reputation for making high-grade electrical equipment, this Ford ignition system has decided advantages over earlier systems.

Extra long graphite-bronze bearings with large diameter shaft reduce wear. Positive lubrication by a cup which forces grease **under pressure** to bearing surfaces. Distributor cup so made that it will not wobble. A special tapered screw makes **accurate timing quick and easy**, without removing distributor or changing the mesh of the gears.

The Delco system provides an automatic spark control that takes care of all ordinary driving speeds, but has in addition a hand advance control that can be used under unusual conditions or whenever desired.

With the Delco system you can start more easily, develop more power and speed, throttle down lower and run more smoothly at all speeds. Quickly and easily installed; full instructions furnished. Operates off either magneto or battery current with one Ford coil, or can be used with special closed contact coil like our K8025. Sold under the guarantee of "money back in 30 days if you are not satisfied." Shipping weight, 8 lbs.



Our Reduced Price
C5537—Complete with cables, etc. 11.35

Timer Brush Assembly

Complete with Spring, Hub, Arm and Roller to fit any Ford roller type timer. Shipping weight, 3 oz.

C5608—For 1913-1923
 18-19-20-21-22. **1.16**



Atwater Kent Closed Contact Coil

A high-power special ignition coil (6-volt), which can be used with Atwater-Kent System shown above or with Bosch system shown at left, when it is desired to eliminate entirely the regular Ford coils and coil box. This coil is non-vibrating and absolutely water-proof—no need to be afraid of the rain. Besides eliminating the noisy vibrators and the coil box, this coil makes starting much easier, because of the hot spark it gives at low engine speeds.

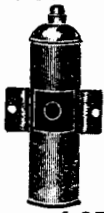

K8025—Each (ship. wt., 1 lb.) 4.65

The Master Rotor for Ford Cars

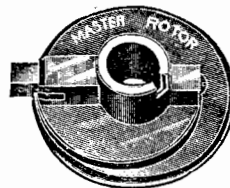

Takes the place of your old timer roller assembly and puts your ignition system in the "big car" class. Can be used with any shell, even after the fibre is badly worn. Brush is made of "Blendite," to give it long wear and perfect contact. Does not use any oil. Makes starting easier and allows slower running in high gear and slower idling. Made

of best grade material throughout and is absolutely guaranteed to improve the running of your motor or your money will be refunded.

C5601—Rotor complete. Our Reduced Price 78

Rush Dual Contact Timer Roller for Ford Cars

Has a wiping side contact that holds the roller in line and never misses. Keeps the track smooth and will smooth out tracks that have become worn. Makes starting easy. Increases gasoline mileage, and will positively prevent engine skipping. Runs in grease and when the case is once filled it requires no attention for from 1000 to 1500 miles.



Will work on old timer cases, as well as new, and will enable you to get from five to ten times as much service out of your timer as you are able to get with an ordinary type brush. Can be used with any style roller type timer case.

C5602—Complete with instructions (wt., 4 oz.) 1.00

"Henry" Timer Brush and Tool

Don't throw away your old timer case just because the race gets rough—smooth it up with a "Henry" timer brush. Simply replaces the regular roller, and runs your car without a miss, while at the same time it smooths out all the "wavy" places. As soon as the race is smooth (after 20 to 50 miles), take the special brush off and put your roller back on. Will add thousands of miles to the life of your timer. Carry one in your tool box.

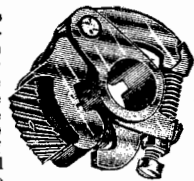

C5579—Each, complete (ship. wt., 12 oz.) 78

OKeh Timer—Guaranteed for Two Years

Here is a new Ford timer, which exhaustive tests have proved to be the best for easy starting, smooth running, increased power, gasoline economy, durability and general dependability. It uses no oil, cannot short-circuit, and gives a good hot uniform spark that lets you use a leaner gasoline mixture, while months of hard usage show no wear that can be detected.

The OKeh timer is an improvement over the ordinary roller timer in materials, construction and design. Instead of using steel for brush and metal segments, the OKeh uses hardened copper, which everyone knows is a better conductor of electricity than steel, and has been universally used in the construction of electric motors and the ignition systems of high-priced cars.

Instead of the fibre insulation of the ordinary timer, which is affected by oil and moisture so that it warps and cracks, the OKeh uses **pure Bakelite insulation**, the highest grade insulator known, absolutely unaffected by heat or cold, oil or moisture. And instead of allowing the brush to run on the insulating material and wear it rapidly the OKeh has a **full metal track** which takes all the wear, and will last indefinitely.

Instead of using a rolling brush, which is so liable to jump and skip, the OKeh timer uses a **wipe-contact rotor**, which is held firmly in contact with the race-way by a steel spring, and **cannot skip**. Instead of the oil required to lubricate the ordinary roller, which gets between the roller and the segments and cuts down still more the strength of the electric current, the OKeh brush is made of copper with enough graphite in it for lubrication and **requires no oil**.

And, instead of a case made in sections, with washers and bushings that shrink and let in moisture to cause short-circuits, the OKeh timer has a **one-piece construction** the insulation being die-cast around the copper segments and the white-brass shell die-cast around the insulation, leaving not the slightest crack where moisture could get in to cause trouble.

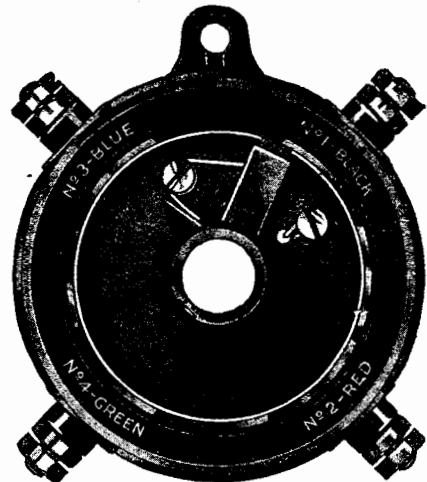

Every OKeh timer is carefully tested and inspected, and is guaranteed for two years. Order one now, try it on your car or truck or tractor for thirty days—then, if you don't find it the best timer you ever used, send it back to us and we will refund every cent you paid us.

C5595—OKeh Timer, complete, (Ship. wt., 1 lb.) **2.95**
 C5596—Extra gauze brush (wt., 2 oz.)..... **.35**

“Red Star” Timer

The Red Star Timer shell is pressed steel, copper coated and then nickel plated. The fiber is the best quality procurable, made to resist oil and water, heat and cold, wear and tear. It won't corrugate and get bumpy as quickly as a cheaper fiber and short circuits are almost impossible. The contact segments are fine steel, made **extra thick** for long wear, and all parts are made with extreme accuracy.

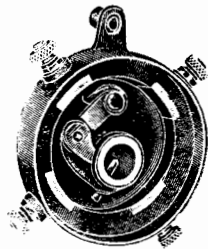

Instead of the ordinary timer roller which drags and chatters against the carrier arm, causing premature wear, wavy race and lip-sided roller, the Red Star uses a **tool-steel roller with fiber ends**, which will not drag or slip. The center pin is extra large, making it virtually a “roller on a roller”; cannot stick or slide. This roller and the extra thick segments add thousands of miles to the life of Red Star timers. The material throughout is the very finest, and you will be pleased with the long service and perfect performance this timer gives. Regular list price, \$1.50. Shipping weight, 1 lb.

Our Reduced Price
 C5560—Red Star Timer..... **1.48**

Ball Bearing Timer

Instead of the ordinary type of brush, contact is made by a ball-bearing assembly, consisting of an outer steel band, which moves on a circle of ball-bearings. The roller absolutely cannot jump or skip, for it is in contact with the race all the time. But it does not wear the race either, because it turns on the ball-bearings, and keeps bringing a different part of the steel band in contact with the race instead of sliding on it.

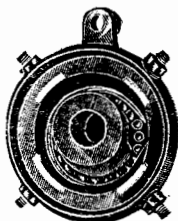

Nothing to wear out or get out of order. Guaranteed for the life of your motor. Furnished for all model Ford cars and trucks, also Fordson tractor. Easy to install; full instructions in every box. Shipping weight, 1 lb.

C5563—Our Reduced Price, complete..... **2.90**

Genuine “Milwaukee” Timer

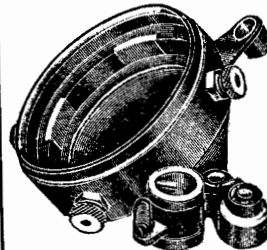

This is the latest improved model of this well-known timer. Has Bakelite case, a perfect non-conductor, heat-, oil-, and water-proof; absolutely prevents short-circuits. Bone-dry Egyptian fiber race, fine steel contact points, hardened steel roller.

C5583—Compl. (wt., 1 lb.)..... **1.58**

Mosler “Spit Fire” Timer

Instead of the ordinary race and roller, this timer has a hardened steel brush held in place by two compression springs so as to make contact on the four hardened steel points on the inside of the case. Can not short-circuit. Can not skip and miss; will give good service indefinitely. Shipping weight, 1 lb.

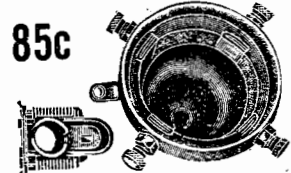

Our Reduced Price
 C5581—Timer, complete with brush..... **.85**
 C5582—Brush only (can be used in any timer).... **.38**

55c

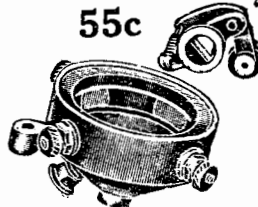

“All-Pep” Timer

An old or worn timer is a source of endless trouble and annoyance. Our “All-Pep” is an extra quality timer with pressed steel case, good grade of fiber and roller. Shipping weight, 1 lb.

C5580—For all model Ford cars, complete **.55**

"Western Giant" Coil Points

A NEW IMPROVED COIL POINT FOR FORD CARS



15c
Per Pair

Our "Western Giant" is a new improved coil point that has proved itself thoroughly serviceable and dependable in the test of actual use. It is made of the best materials, with genuine Tungsten contact points, and will give a good hot spark at any engine speed.

As shown by the illustration, the contact point on the vibrator is larger than the one on the bridge. This makes them easy to adjust, since it is impossible to get them out of line with each other, which is the reason so many of the ordinary contact points burn out without giving the service they should.

Fit right on in place of the regular points; no changes to make. Sold only in pairs. Shipping weight, 2 oz.

C5705—"Western Giant" Coil Points, per pair. **.15**
Full set of 4 pairs. **.50**

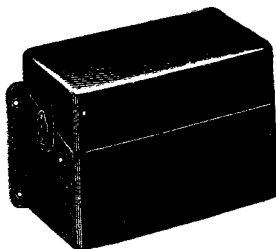

Coil Box Parts for Ford

Regular Ford metal coil box with lid, also porcelain insulator posts in back which extend through dash. Fine black enamel finish. Ship wt. 5 lbs. Coil units are not included.

C5674—Coil Box without switch for cars having switch on instrument board (see illustration) **1.35**

- P5004 —Coil Box Cover only, 1915-24. **.35**
- P5005B —Switch Cover only, 1918-22. **.30**
- P5819 —Switch Cover Screw, 1914-22. **.01**
- P5810 —Coil Box Porcelain, 1914-24. **.05**
- P5012 —Ignition Switch on Instrument Board, 1919-24. **.90**
- P5014 —Starter Switch on Floor Board, 1919-24. **.58**

Switch Key

Regular style for Ford car. Shipping wt., 4 oz. J7663—Each. **.05**



Switch Keys for Ford Cars with Starters



We can furnish a key for any regular Ford ignition switch. It pays to keep an extra key on hand. Be sure to give number stamped on the lock. This number is also stamped on the key. Shipping weight, 2 oz.

A5040—Each (specify number) **.10**

Keytainer for Switch Keys

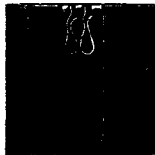

A handy leather case especially designed for the motorist's switch keys. Has clip on back to hold it to pocket. Glove fastener to keep it securely folded. Made of genuine leather.

Size open 3x3 3/4 in. Size folded 3x1 in. Ship. wt., 4 oz.

E6598—Keytainer, complete. **.89**

Genuine K. W. Coil Points

FOR FORD CARS



16c
Per Pair

K. W. Coil Points have long been recognized as one of the best on the market. The plates are of the very best. Our C5700 is the kind formerly used as standard equipment on Ford cars, with a recent improvement of making the points larger than formerly. Will last much longer than ordinary points and give more satisfactory service. Shipping weight, pair, 2 oz.

C5700—Genuine K. W. Coil Points, per pair. **.16**
Full set of 4 pairs. **.68**

Standard Tungsten Coil Points

FOR FORD CARS

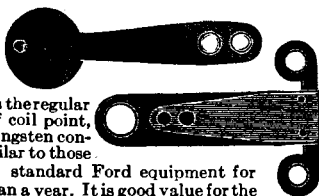

10c
Per Pair

This is the regular grade of coil point, with Tungsten contact similar to those

used as standard Ford equipment for more than a year. It is good value for the money, but for real service and dependability we recommend the "Western Giant" or "K. W." points shown above as well worth the difference in price. Sold only in pairs. Ship. wt., pair, 2 oz.

C5884—Regular grade coil points, per pair. **.10**

Genuine Coil Units

FOR FORD CARS AND FORDSON TRACTORS

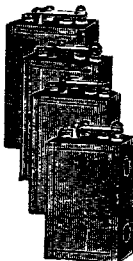

These coil units are identical with those furnished as regular equipment on Ford cars and Fordson tractors, having now the larger and heavier points, heretofore used only on Fordson. They are interchangeable with coil units used on all Ford cars since 1914. Coil units should not be neglected for they are frequently the cause of trouble blamed on carburetor, magneto or spark plugs when they show signs of weakness they should be replaced with new ones. Shipping wt. 2 lbs.

C5670—Standard Coil Unit, Tungsten Points, for Ford Cars or Trucks or Fordson Tractors, each **1.29**

Baby Screw Driver



Made especially to reach into close places. Very handy for attaching wire. **Our Reduced Price**

to all kinds of lamp sockets. H7309—Each (Shipping wt., 4 oz.) **.10**

Auto Electrician's Tool Kit

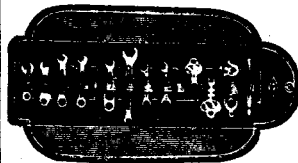

A complete kit for mechanic or car owner, covering all requirements in connection with overhauling, repairing and adjusting magnetos and ignition systems. Contains 12 pieces, consisting of Magneto

Wrenches, Keys, Screw Driver and Contact Aligner. For use with all ignition systems. A real necessity for every repair man. Well made, durable tools. Shipping wt., 8 oz. H7351—Electrician's Kit. **.89**

File For Coil Points

It is a well-known fact that a large percentage of ignition trouble comes from dirty or pitted coil points and no matter how good the rest of the ignition system is, the car will not run well unless the points are clean. The file

we offer to do this work is made for the purpose and you will be surprised to see how easy it is to keep the points in condition with the right tool.

H7330—Coil Point File (Ship. wt., 2 oz.) 10

Elbow and Straight Plugs

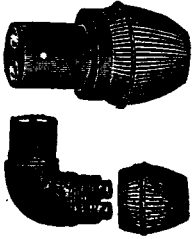

Made of hard rubber, with screw cap. Very handy and desirable. Cap acts as a support for the connecting cable, relieving strain on the terminals. Length, 1 1/2 inches; diameter, 1/8 inch. Wt., 2 oz.

- C5744—Elbow plug, double contact 17
- C5745—Elbow plug, single contact 17
- C5746—Straight plug, double contact 8c
- C5747—Straight plug, single contact 8c

Push and Pull Lighting Switch

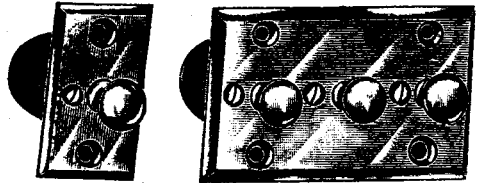

One of the neatest, simplest and most easily installed switches on the market. All that is necessary is to bore a 3/8-inch hole, or in case of a multiple gang switch, holes with 3/8-inch centers.

Primarily for lighting, as pulling out the button closes an individual circuit and pushing it in opens the circuit. Multiple gang switches have a common bus bar for the battery wires. Shipping weight, each, 6 oz.

- C5731—1 Gang, 1 1/2" high, 1" wide22
- C5732—2 Gang, 1 1/2" high, 1 1/8" wide44
- C5733—3 Gang, 1 1/2" high, 2 1/4" wide66

Lamp Sockets

Lamp bulb sockets, with or without screw and spring attachment shown in illustration. Ship. wt., 2 oz.



Adjusting Type

- C5736—Double contact (for Ford headlights) 19
- C5735—Single contact 19

Plain, Without Attachment

- C5727—Double contact 15
- C5728—Single contact 15

Lamp Socket

A well-made socket that insures a tight connection at all times. Made with strong Ediswan spring connections. Screw terminals. Shipping weight, 2 oz.

- C5748—Double Contact. Each 12
- C5749—Single Contact. Each 12

Ediswan Capped Socket

Used generally with capped plug C5746-47. Used where you desire to break connections, without interfering with wiring. Screw terminals. Nickel finish, with hard rubber cap. Wt., 2 oz.

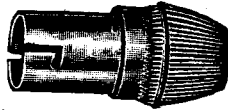

- C5750—Two-point contact 14
- C5751—One-point contact 14

Double to Single Plug

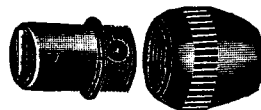

If you have a single-contact dash lamp or socket, and wish to use a double-contact trouble lamp or spotlight, use this Single-to-Double plug. Ship. wt., 2 oz.

- C5758—Single to Double Plug 18

Tail Lamp Plug

Plug for tail lamp, made of hard rubber with screw cap for protecting the connection. Contact points are of brass and are well soldered. Ship. wt., 2 oz.

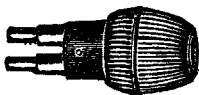

- C5752—Single Contact. Each 12
- C5753—Double Contact. Each 12

Caps Only, For Light Plugs



High-grade hard rubber cap with threads to fit any style plug. Shipping weight, 2 oz.

- C5743—Our Reduced Price, each 4c

Toggle Switch

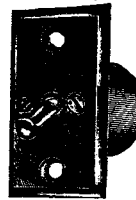

Instead of using a pull or push action, this switch uses a toggle lever, which is pushed up or down to turn lights on or off. Has the advantage that you can tell by looking at the lever how the lights are. When the lever is up, the lights are on; when the lever is down, the lights are off. Finished in high-grade black enamel. Shipping weight, 6 oz.

- C5756—1 gang 19

Concealed Type Push and Pull Switch

A high-grade lighting switch that is very popular because it can be installed without cutting such a large hole in the dash or instrument board. Simply drill 3/8" hole, push stem of switch back through it and tighten lock nuts. Only part which shows is the plunger. Works on either metal or wood supports, up to 3/4" thick.

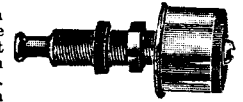

- C5729—Each (shipping weight, 6 oz.) 29

Combination Dash Socket

For Wood or Metal Dash



Has threaded shank with nut—will fit any wood or metal dash up to 1/2" thick. Made with single or double contact. Shipping weight, 2 oz.

- C5762—Double contact. Each 19
- C5763—Single Contact. Each 19

NEVER-FAIL Generator Cut-Out

Many Ford owners have complained that the regular cut out furnished with starters is not entirely satisfactory. A good generator cutout is an absolute necessity, because, when it is out of order, the storage battery can discharge itself through the generator, even when the current is cut off. Our "Never-Fail" Cutout is guaranteed and can be depended upon. Shipping weight 8 oz.

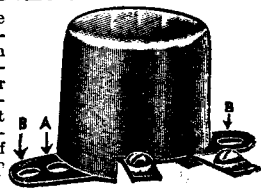

- C5604—"Never-Fail" Cutout 1.48
- C5606—Regular Ford Cutout68

NEW STROMBERG CARBURETOR

WITH HOT SPOT MANIFOLD. FOR FORD CARS

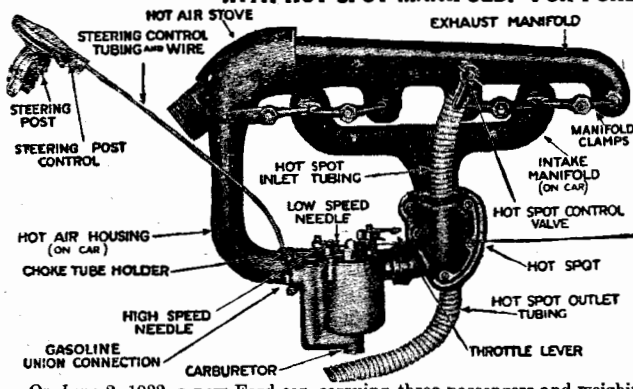

Wouldn't you like your Car to develop more power and use one-fourth less gasoline? And wouldn't you like to pull powerfully at 4 or 5 miles per hour on high gear and still be able to open your throttle suddenly for a quick "get-a-way" without choking or stalling your motor?

Our new Stromberg will do this or we will refund your money. Your old carburetor is costing you more than the price of a new one every few thousand miles. Get a Real Carburetor for your Ford, then put your ignition system in good shape and grind your valves, etc., and you will have a Real Car.

FACTS OF THE OFFICIAL A. A. A. TEST

51 6-10 miles on one gallon of 57-deg. test gasoline.

On June 2, 1922, a new Ford car, carrying three passengers and weighing 2,370 pounds, did it with a New Stromberg Carburetor. Economy alone does not make a perfect carburetor, and, realizing this, the car was given most severe acceleration and speed tests. It accelerated from a standing start to 25 miles per hour in 11 4-5 seconds, made a speed of 45 miles per hour, and throttled down to 6 miles per hour without any jumping or jerking.

The great desire of every car owner is to reduce the cost of fuel. Now is your one big opportunity to really save money on gasoline, and at the same time have a better car—have more power and speed, quicker acceleration, and more flexibility, knowing at the same time you have the most reliable instrument on the market. The entire carburetor and equipment, including housing, tubing and steering post control. No filing or fitting to be done. Every car cannot be made to get 51 miles on a gallon of gasoline as it may not be in perfect running condition otherwise, but a Stromberg is guaranteed to increase your present mileage 25% to 40%, and give your car more power. **D6028—Complete with hot spot manifold for Ford cars. Shipping weight 18 lbs. Our Reduced Price 14.65**

OUR 30 DAYS TRIAL OFFER

Send us your order today for a new Stromberg carburetor—use it on your car for thirty days—watch the big saving in gasoline—notice the increased power and how much smoother your motor runs—then if you feel like you can afford to go back to your old carburetor, just return the New Stromberg to us at our expense and we will return every cent you paid us.

Stromberg Carburetors for Popular Cars

Stromberg carburetors are used as standard equipment on fully one-third of American-made automobiles. They start easiest, go farther on less gas, and are always dependable—do not need constant adjustment. Can be furnished for any car; if your car is not shown, write for price. Average shipping weight, 10 lbs.

X8865—Buick 6, 1918-23	21.60	X8877—Star, 1922-24	16.00
X8866—Chandler, 1914-24	17.50	X8872—Hudson Super Six, 1916-21	29.00
X8867—Chevrolet 490 and Superior	17.50	X8873—Maxwell, 1918-23	17.00
X8868—Dodge, 1916-24	16.65	X8874—Nash 6, 1918-22	20.75
X8869—Dort, 1918-22	17.10	X8875—Overland 91, 1920-23	15.75
X8870—Durant 4		X8876—Willys-Knight 1920-24	17.10

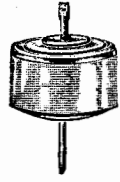

Float for Stewart Vacuum Tank

An accurately made float that replaces the regular Stewart model on vacuum feed systems. Guaranteed to fit perfectly and give the best of service. Ship. wt., 12 oz.

D6074—Our Reduced Price, each .35

Copper Tubing

High quality copper tubing; 1/4, 3/8 and 1/2 inch in diameter. Shipping weight, 8 oz. per foot.



	Price, per foot
D6070—3/8 inch outside	7c
D6067—1/2 inch outside	8c
D6066—3/8 inch outside	9c
D6068—1/2 inch outside	.10
D6069—12-foot length 3/8 in. copper tubing, per piece	1.05

Flexible Metal Tubing

Used to conduct hot air from the exhaust pipe to the air intake on the carburetor. A great help in starting and saves fuel by making the gas hot. Asbestos packed in joints, making it practically air tight. Sizes shown are inside diameters. Shipping weight, about 1 1/2 lbs. per foot.



	Price per Foot.		Price per Foot.
D6060—7/8 inch	.19	D6063—1 1/4 inch	.24
D6061—1 inch	.21	D6064—1 1/2 inch	.32
D6062—1 1/8 inch	.22	D6065—1 3/4 inch	.45

Carburetor Adjuster and Choker

FOR FORD CARS

Here is just the device that owners of Ford cars with starters have been looking for. With the equipment furnished on the Ford car you can choke your carburetor from the seat but you cannot adjust it. With this device you can perform both of the operations from the drivers seat. Thus you are able to keep your carburetor adjusted for different conditions. Comes complete. Easy to attach, full instructions, Ship. wt., 1 lb. For all Ford cars with cowl board.



D6187—Our Reduced Price. .80

Priming Cups, Drain Cocks and Stop Cocks

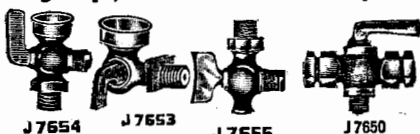

J7653—Angle Priming Cup, regular 1/8" pipe thread	.22
J7654—Upright Priming Cup, regular 1/8" pipe thread	.22
J7655—Drain Cock for crank case, carburetor, or radiator, 1/8" thread, (Ford size)	1.00
J7656—Drain Cock, 1/4" thread	1.00
J7650—Stop Cock, for 1/4" tubing	1.00
J7651—Stop Cock, for 3/8" tubing	1.00

Improved Kingston Carburetor FOR ANY MODEL FORD CAR

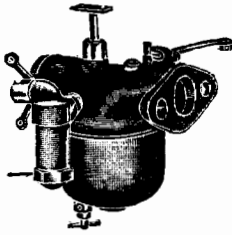

This is the new model L4K Kingston carburetor, with special gasoline strainer to filter the low-grade gasoline now in use. Makes a big difference in the running of your motor and the mileage you get per gallon. Prevents clogged needle valves and the annoyance that results. Strainer is easy to get at for cleaning. Carburetor fits Ford manifold and rods without extra fittings. Ship. wt., 4 lbs. **D6021—Complete 4.45**

Holley "Hot Shot" FOR FORD AND CHEVROLET

A combination exhaust and intake manifold assembly that takes the place of the ordinary manifold on Ford motors. By heating the intake from the exhaust, gasoline is rendered extremely volatile, making car start more easily and quickly, give much more power and save one-third on gasoline. Can be installed complete in 30 minutes—no complicated parts to assemble or holes to drill—only a few bolts to fasten. Regular price, \$11.00. **Carburetor not included.**
D6018—Holley Hot-Shot for Ford (wt., 10 lbs.) 9.65
D6019—Holley Hot-Shot for Chevrolet 490 or Superior, not illustrated (8 lbs.) (regular price, \$7.50) 5.95

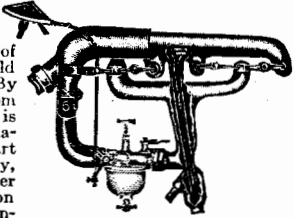

Holley Carburetors

FOR FORD AND CHEVROLET

This model NH Holley is used as factory equipment on Ford cars, and possesses all the latest features of automatic carburetor construction; especially adapted for the Model T Ford car. Fits manifold and operating rods without any extra fittings. Ship. wt., 4 lbs.

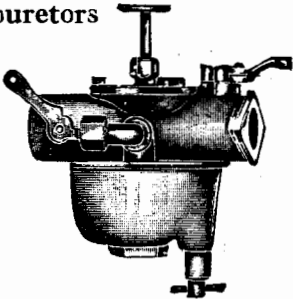

D6032—For all models of Ford cars 3.85
D6029—Holley Carburetor for Chevrolet 490 or Superior (not illustrated) 8.95
X8884—Chevrolet Carburetor, complete with D6019 Hot Shot listed above (12 lbs.) 12.95

Carburetor Parts for Ford Cars



KINGSTON CARBURETOR PARTS

D6038 Float assembly, 1921-24.....**.45**
D6040 Float assembly 1917-20.....**.45**
D6042 Float with lever, 1915-16.....**.45**
D6044 Gasoline valve, 1917-20.....**.45**
D6039 Gasoline valve, 1921-24.....**.45**
D6045 Spray needle assembly, 1910-24.....**.45**

HOLLEY CARBURETOR PARTS

6047 Float with lever, 1913-19.....**.40**
D6052 Float with lever, 1920-24.....**.40**
D6049 Spray needle assembly 1914-20.....**.20**
D6053 Spray needle assembly 1921-24.....**.20**
D6051 Gasoline inlet needle, 1914-24.....**.20**

CARBURETOR ATTACHMENTS

P4129A Carb. adjusting rod.....**.15**
P4130 Carb. flange bolt and nut.....**.15**
P4134 Carb. flange gasket.....**.15**
P4431 Carb. printing rod.....**.60**

Genuine

CONCENTRATED
Boyce-ite



Poured into gasoline, Boyce-ite removes carbon knocks, prevents carbon from forming, makes motor start more easily and run more smoothly and with more power, giving one to three more miles to every gallon of gas. Boyce-ite is an oil compound, instantly soluble in gasoline, producing a rapid-firing carbon-destroying fuel. After 25 to 500 miles of driving, carbon knocks will disappear, and if you use Boyce-ite every time you buy gasoline, you will never have to remove carbon, clean spark plugs or grind valves. Try a package of three 4-oz. cans, and give it a thorough test under our guarantee of "Satisfaction or Money Back."
Our Reduced Price

G7056—4-oz. can, per can..... 28
G7056A—Carton of 3 cans (ship. wt., 1 lb.)..... 78
G7055—1/2-gallon size (wt., 5 lbs.)..... 2.65

Kingston Carburetor Adjuster for Fords

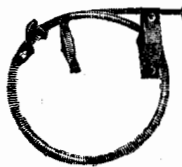

Brings your carburetor adjuster right up on your steering column, where you can reach it without leaning forward and neglecting the steering wheel. Simply pushing or pulling on the button lets you make a full one-third turn of the carburetor needle. Easily installed. Nothing to get out of order.
D6237—Complete with instructions (ship. wt., 1 lb.)..... 1.25

Kingston DeLuxe Carburetors

FOR POPULAR CARS

These well-known high-grade carburetors come complete with gasoline strainer, also have the carburetor adjuster shown above. Shipped from factory or warehouse at Kansas City. Shipping weight, 5 lbs.

D6267—Carburetor complete for Dodge cars.. 13.65
D6268—Carb. complete for 1918-23 Maxwell.. 13.65
D6969—Carb. complete for 1920-23 Overland. 13.65
D6270—For Chevrolet 490 and Superior..... 13.65

Mile-Maker Tablets

Much of the gasoline today is very low grade and consequently deposits too much carbon. Mile-Maker Tablets used in this same gasoline will show a marked increase in mileage, power and



speed. Positively harmless, will not injure motor or interfere with lubrication, but really assist by removing carbon. Also makes your car easier to start. You are losing several times the cost of Mile-Maker Tablets on every 100 gallons of gas you now use, not to mention carbon trouble. Satisfaction absolutely guaranteed or your money back.

Box of 100 tablets, enough to treat 100 gallons of gasoline, with full directions. Ship. wt., 8 oz. **Our Reduced Price**
G6943—Box 100 Mile-Maker Tablets..... .39

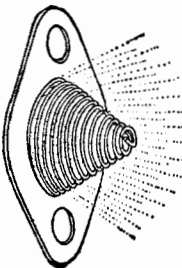

"Little Wizard" Gas Saver

Replaces the gasket that fits between the Ford carburetor and the intake manifold. Has a cone-shaped spiral spring which is kept in vibration by the running of the motor, thus effectually breaking up the small drops of unvaporized gasoline that would otherwise be wasted. Nothing to wear out, clog up or get out of order. Easily installed and will last indefinitely. Soon pays for itself. Satisfaction guaranteed. Ship. wt., 4 oz.

D6205—Our Reduced Price .42

GENUINE "COOPER" POSITIVE CUT-OUT

MAKES YOUR MOTOR "PEPPY"—COVERS THE ROAD WITH A "BIG NOISE."

The Cooper Cut-out absolutely and positively cuts the muffler out, causing all the gases to pass outward at an easy angle. The discharged gas passes through a large oblong opening which intensifies the sound, enabling you to "feel the pulse of your car." It tells you instantly of any slight "miss" or weak firing that may develop from shorted plugs, poor compression, imperfect mixture or other causes. It also relieves the back pressure of the exhaust gases on the motor, thereby lessening heating and carbon trouble. When your motor begins to labor on a hard pull or going up-hill, just step on the cut-out and you can feel the engine respond with more pep and power.

The Cooper Cut-out has a very large valve, with a large opening. It clamps over the pipe and is easily and quickly installed. The pipe does not have to be cut in two, just the bottom part of it cut away for a distance of about three inches. With cut-out in place the exhaust pipe is as strong if not stronger than before. The flapper rises up in the valve and entirely shuts off the passage to the muffler when cut-out is opened, making a positive cut-out very loud and sure to work.

Flapper is held shut by a strong, substantial spring, which heat will not weaken, so that valve cannot flutter or cause back pressure, neither will you be caused any trouble or annoyance by the cut-out making a noise when you have it closed.

Outfit consists of valve, cable and pulley. For pedal or dash control, see the articles described at the bottom of this page. Comes securely packed in carton, with full instructions. Average shipping weight, 4 lbs.

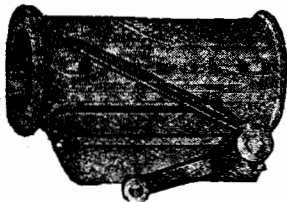

**FOR ALL CARS
\$1.98 and Up.**

B5423—Size 1 1/2" (Ford size)	1.98	B5427—Size 2"	3.10
B5424—Size 1 3/4"	2.65	B5428—Size 2 1/4"	3.40
B5425—Size 1 3/4"	2.65	B5429—Size 2 1/2"	3.40
B5426—Size 1 3/4"	2.65	B5422—Spec. for Chevrolet	3.45

For Pedal or Hand Control, See Below

Regular Style Cut-Out

This is the regular type of valve which is in universal use. It is made from strong cast steel. Ours is especially well made, having tight fitting valve, butterfly type, and the opening is much larger than the ordinary—full 2 inches—making a very loud cut-out. Many houses charge from \$1.00 to \$1.50 for cut-outs not as good as this one. This is the best of its kind, but we recommend the higher grade cut-outs shown on this page as they give better satisfaction. Locking pedal and cable furnished. No pulley required.

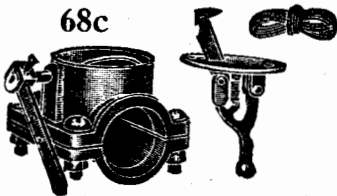

B5419—Each complete, for Ford cars only (wt., 3 lbs.) . . . **.68**
B5420—For Chevrolet 490 and Superior (3 lbs.) . . . **.98**

G. M. C. Muffler Cut-Out

FOR ALL CARS

A well-made substantial muffler cut-out and engine-testing valve. Positively shuts off all discharged gases from the muffler, and forms an easy but positive outlet which eliminates back pressure. This lessens overheating and carbon deposits, and increases power, especially on a heavy pull. When valve is closed, the passage to the muffler is as free as before, while the heavy spring holds the flap securely and prevents any leak. Accurately machined and easily installed. Comes complete with locking pedal, cable and pulley. Shipping weight, 3 lbs.



B5468—Size 1 1/2" (Ford size)	1.98
B5462—Size 1 3/4"	2.65
B5463—Size 2"	3.10
B5464—Size 2 1/4"	3.40
B5465—Size 2 1/2"	3.40

Perfection Cut-Out and Safety Valve

FOR FORD CARS

One of the most practical and most substantial cutouts we have ever handled. The body is long and solid, but is very little heavier than ordinary cut-outs, as the top is only a pair of brackets instead of being solid, there being no need of a solid top. The valve is made in a "Y" shape so the exhaust does not have to make a square turn to get out. It is also a safety valve as the valve like a door held shut by a spring, and in case of back fire the valve will open, releasing the pressure of the explosion thus saving the muffler from being blown up. It is accurately made and the valve fits tight. Easily installed by anyone. Complete with heavy strong locking pedal which will stay open when locked. All parts are well made and nicely finished. Shipping wt., 3 lbs.



B5410—Perfection Cut-Out Outfit (for Fords only) **1.10**

Clamp-on Dash Control

For Cut-outs and Exhaust Horns

The handiest control made for cut-outs, exhaust horns, air chokes, radiator shutters, etc. Always at your finger tips and in plain sight of the driver. Fits the hand perfectly, and a twist of the wrist locks it in any position.



Easily installed. Simply clamps on instrument board with set screw—no holes to drill—no interference with levers, pedals or floor board. Made of brass and steel with exposed parts handsomely nickel-plated. Tube and cable about 56 inches long. (Shipping weight, 1 lb.)

B5393—Each complete. **1.50**

Cut-out Pedals, Pulleys and Cable

Extra attachments for cut-outs and exhaust horns B5394 is the regular plain locking pedal, shown at left in illustration. B5395 is the improved Cooper pedal No. 4, shown at right, which gives better leverage, is neater and more easily installed and will last longer. Ship. wt., 1 lb.



B5394—Plain locking pedal	1.50
B5395—Cooper No. 4 locking pedal	1.50
B5396—Cut-out pulley (Ship. wt., 4 oz.)	1.50
B5397—Heavy cut-out cable, per foot	1.50
B5392—Cutout spring	1.50

Hand Lever Lift

FOR CUT-OUTS AND EXHAUST HORNS

Fastens on floorboard of speedsters and other cars with low seats, or on panel below seat cushion on Ford or Chevrolet. Easy to operate; easy to install. Holds itself in open position. Attractive black enamel finish. **Our Reduced Price**

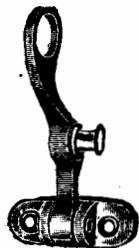

B5411—Lever Lift (ship. wt., 12 oz.) . . . **.78**

Spark Plug Intensifier

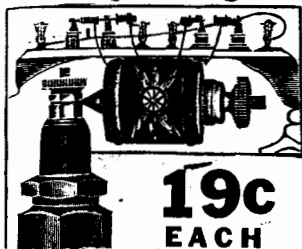

19c EACH

Shows you instantly which plug is missing. Makes your old plugs work like new.

The Spark Plug Intensifier is just what its name implies—an ingenious little device that intensifies the spark, keeping sooted or carbonized spark plugs firing every time.

By means of the Spark Plug Intensifier you can see immediately which plugs are firing. The extra gap between the two terminal points is encased in a glass cylinder and it tells the story at a glance. A great help in locating ignition trouble; simply raise the hood and watch the sparks and in a jiffy you can find the trouble—no guessing.

A set on your car will increase spark plug efficiency by giving a more intense spark, save much spark expense and carbon trouble. They are simple to install; complete instructions furnished. Shipping weight, each, 2 oz.

Our Reduced Price

D5992—Spark Plug Intensifiers, each.....	.19
Set of 4 (ship. wt., 6 oz.).....	75
Set of 6 (ship. wt., 8 oz.).....	1.05

Fire Cup FOR ALL CARS

Will positively prevent fouling of plugs in oil-pumping cylinders

When oil gets by the pistons, it burns and forms carbon, which collects around the points of the spark plug and soon covers them so completely that they will not fire at all. This causes the motor to run unevenly and wastes a great deal of power and fuel. Our "Fire Cup" is a simple but effective device to overcome this trouble. Forms an extension for the spark plug which lifts the sparking points up out of the way of the oil. Also increases

the effectiveness of the spark by igniting first the gas that enters the Fire Cup and shooting a red hot flame into the cylinder to ignite the gas there.

Order a set of Fire Cups and if after 10 days' trial you are not absolutely satisfied, return them and we will refund your money. Shipping weight about 8 oz.

D6075—"Fire Cup" for Ford or any car using 1/2" plug	.28
Set of 4.....	.96
D6076—"Fire Cup" for any car using 3/8" regular or 1/2" extension spark plug.....	.29
Set of 4.....	.98

SPARK PLUG BRUSH

This handy Brush is very convenient for cleaning plugs. Shipping weight, 4 oz.

D5998—Spark Plug Brush.....	.13
-----------------------------	------------

"Utility" Wrench for Ford



Made with socket on one end to fit Ford cylinder head cap screws and lug bolts. The open end fits Champion X Spark Plugs and the wrench has the proper curve to make it reach the plugs easily. Plain black finish. Length about 10 inches. Shipping weight, 1 1/2 lbs.

H7189—"Utility Ford Wrench.....	.26
---------------------------------	------------

Double-End Spark Plug Wrench

A very handy tool for removing and replacing spark plugs. Two wrenches in one. Will fit almost any make and size of plug. Shipping weight, 8 oz.

H7582—Openings 1/2 and 1 1/4, fits Champion X Plugs.....	.28
H7583—Openings 1/2 and 1 1/4, fits Western Giants.....	.28

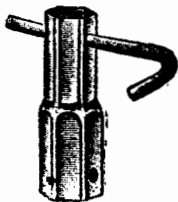

"Sure-Shot" Spark Plug Amplifiers

Give a Hotter Spark—More Power—Easy Starting—Stop Oil Pumping—Eliminate Carbon and Save Gas

If you are bothered with a motor that pumps oil, fouls spark plugs, wastes gas, or carbonizes badly the chances are you need a hotter spark. Sure Shot Spark Plug amplifiers enlarge and broaden the spark. Plugs that formerly fouled and cylinders that pumped oil will be clean and dry and fire with full power, giving your motor more power, less carbon as well as saving gas. Can be installed on practically any spark plug in two minutes by anyone. After installing you will be delighted to see your car go whizzing up hills on high where you formerly had to shift gears. You will also notice a big increase in your mileage from gasoline and easier starting.

Sold with our absolute guarantee of satisfaction or money back. Prices shown do not include spark plug. Ship. wt., 2 oz.

D5999—Sure Shot Amplifiers, each.....	.10
---------------------------------------	------------



Airco Ignition Gauge

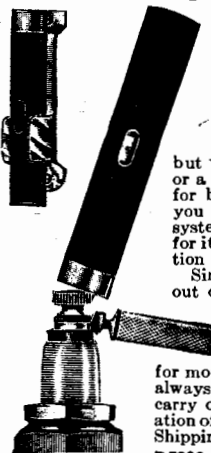

Ignition trouble is always exasperating, because it is so hard to locate. But with an Airco Gauge it is easy. Simply touch the end to your spark plugs, wires, distributor, etc. The Airco is a scientific instrument that will not only tell you whether a plug is firing at all, but whether it is giving a hot spark or a weak one. Tests out all wiring for breaks and short circuits. Lets you see what your entire ignition system is doing. Will more than pay for itself the first time you have ignition trouble.

Simple to operate, nothing to get out of order. Full instructions furnished. Can be used on any car or motor. Fully guaranteed. New improved gauge is equipped with clip and screws. For mounting on dash where gauge will always be handy. Every motorist should carry one and save the time and vexation of trying to locate ignition trouble. Shipping weight, 8 oz.

D5990—Each, complete.....	.69
---------------------------	------------

Spark Plug Gasket

Best quality gaskets for 3/8 spark plugs. Will not work on Champion X plugs. Weight, 2 oz.

D5997—1/2 dozen.....	8c
----------------------	-----------



Extra Gaskets for Champion X and Horse Shoe Plugs

High grade copper gaskets, made to fit Champion X and Horse-Shoe spark plugs to prevent loss of compression between porcelain and shell. Ship. wt, set, 4 oz.

D5988—Upper Gaskets, set of 4....	9c
-----------------------------------	-----------

D5989—Lower Gaskets, set of 4....	9c
-----------------------------------	-----------



Dayton Spark Plug Wrench

Fits Champion X



Spark Plugs

Made of strong material, black finish. The two openings will fit nearly all plugs. One of the handiest tools made. Being offset, reaches plugs easily. Ship. wt. 1 lb.

H4764—Dayton Wrench, e.....	.19
-----------------------------	------------

SPARK PLUGS









Proper Size
and Style
For Every
Car

63 ¢



Regular List
Price \$1.00
Our Special
Reduced Price

63 ¢

<p>Dodge Special</p>  <p>D5973—Special for Dodge, 63</p>	<p>Genuine A. C. Plug</p> <p>$\frac{3}{8}$" Long</p> <p>$\frac{3}{8}$" Extension</p> <p>Extension type, $\frac{3}{8}$" thread, large body. For Buick, Chevrolet, Kissel-Kar, Scripps-Booth 4, Stephens. Ship. wt., 5 oz. Regular list price \$1.00.</p> <p>Our Reduced Price D5978—$\frac{3}{8}$" Long..... .63</p>	<p>Ford Special</p>  <p>D5974—Our Reduced Price... .43 L5993—Extra Porcelain... .25</p>	<p>A. C. Special for Fords</p> <p>43c</p> <p>Has long curved point coming up below electrode, so that oil drips off without bothering the spark. Saw tooth edges on core get extra hot, keeping carbon burned off, preventing fouling. Regular price, 75c. Ship. wt., 5 oz.</p>  <p>D5971—Fits Reg. etc. .63</p>
<p>$\frac{7}{8}$" Regular</p> 	<p>Genuine A. C. Plug Regular $\frac{7}{8}$"</p> <p>Regular $\frac{7}{8}$" thread, large body. For Allen, Briscoe, Cadillac, Case, Chalmers, Cleveland, Cole, Dort, Elgin, Gardner, Hudson (up to 1921), Hubmobile, Jackson, Jordan, King, Liberty, Lincoln, Maxwell, Moon, Olds 8, Packard, Peerless, Pierce-Arrow, Ranger, Velie, Westcott, and a large number of other cars, trucks and tractors. Ship. wt., 5 oz. Regular list price \$1.00.</p> <p>Our Reduced Price D5977—$\frac{7}{8}$" Regular A C Titan .63</p>	<p>Genuine A. C. Plug $\frac{7}{8}$" S. A. E.</p> <p>Regular $\frac{7}{8}$" thread, small body. For Apperson 6 and 8, Durant 6, Haines (up to 1921), Lexington, Marmon, Mitchell, Monroe, Standard 8, Stearns-Knight, Studebaker, Stutz, and a number of other cars, trucks and tractors, also the Delco Lighting Plant. Ship. wt., 5 oz. Regular list price \$1.00.</p> <p>Our Reduced Price D5979—$\frac{7}{8}$" S. A. E. A C Titan .63</p>	<p>$\frac{7}{8}$" S A E</p> 
<p>Nash Special</p>  <p>D5982—Spec- for 1919-24 Nash... 63</p>	<p>Genuine A. C. Plug $\frac{7}{8}$" Long Body</p> <p>Extra heavy, long body type, $\frac{7}{8}$" thread. For Chandler, Haynes Model 75, White, Winton, Willys-Knight. Ship. wt., 5 oz. Regular list price \$1.00.</p> <p>Our Reduced Price D5972—$\frac{7}{8}$" long body..... .63</p>	<p>Regular Metric</p>  <p>Genuine A. C. Plug</p> <p>Metric thread type. For Duesenberg, Essex, Hudson 1921, Rolls-Royce, and Racing type Rajo Head. Ship. wt. 5 oz. Regular list price \$1.00.</p> <p>Our Reduced Price D5983—Reg Metric .63</p>	<p>S. A. E. Long</p>  <p>Genuine A. C. Plug</p> <p>Extension type, $\frac{7}{8}$" thread, small body. For Durant 4, Franklin, Nash 1918-19, Oakland, Olds 4 and 6 Premier, Saxon. Ship. wt. 5 oz.</p> <p>Our Reduced Price D5981—S.A.E. long .63</p>

Western Giant Plugs

GUARANTEED FOR THE LIFE OF YOUR CAR

You can not realise how much better results Western Giant Indestructible Plugs give than ordinary plugs, until you try and see what a big difference they make in the running of your motor. You have very likely experienced that uneven, jerky and sluggish running of your car and wondered why you were unable to make it run smooth with that delightful purr which it should have. Lack of uniform ignition in each cylinder is the usual cause of uneven firing.

Western Giant Indestructible Spark Plugs not only produce the same even spark in each cylinder, but on account of their scientific construction, nickel electrode and giant stone core, we believe they are as near perfection as science can attain in spark plug making. They are sold under our iron-clad, unconditional guarantee of free replacement in case of trouble from any cause whatsoever during the full life of the motor in which they are first installed. By merely preventing the waste of gas that takes place every time a cylinder misses, they will soon pay for themselves in the saving of fuel alone.

Western Giant Spark Plugs are almost twice as heavy as the ordinary plug, with a large nickel-alloy electrode that carries the current with least resistance.

The core is the famous "775" grey stone adopted by the U. S. Government for Liberty Motors during the war, after tests which proved it to be the best insulating material that science has been able to produce. Western Giant "775" grey stone cores will stand the greatest heat and vibration, being almost twice as large as an ordinary core, making them almost indestructible.

The special knife-edge firing point is so constructed as to concentrate the spark. The intense heat on this thin point burns off any carbon that might collect and insures a broad, sharp, hot spark every time.

Take advantage of our special 30-day Trial Offer now. Why continue to put up with all the trouble and expense of spark plug trouble when for the small sum of \$2.35 you can put an end to it for as long as your motor lasts?

One extra grey stone core with gaskets is furnished with each set of plugs for use in case of accident. Ship. wt. per set, 1 1/2 lbs. In ordering either plugs, cores or gaskets be sure to give make, model and year of car.

- D6033—Set of 4 plugs for any car, with extra core **2.35**
- D6034—Set of 6 plugs for any car, with extra core **3.45**
- D6035—Single plug for any car, wt., 4 oz., each **.65**
- D6036—Extra core for any plug, wt., 2 oz., each **.35**
- D6030—Extra gaskets, upper, set of 4 **.....9c**
- D6031—Extra gaskets, lower, set of 4 **.....9c**

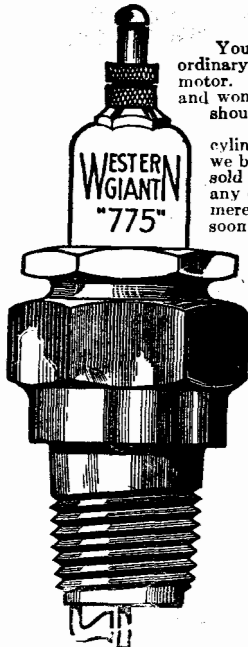

30 DAY TRIAL
 Try a set of Western Giant Plugs for 30 days and if not perfectly satisfactory in every way, your money will be cheerfully refunded.

Horse Shoe Porcelains



FOR FORD CARS
 Special high-grade porcelains that fit perfectly in Horse Shoe, Champion X or Champion Ford plugs for Ford cars. Come complete with gaskets and electrode. Carefully packed. Shipping weight, about 2 oz. each.

- D5980—Each... **1.10**
- Lot of 4..... **.39**
- Lot of 6..... **.58**

Horse Shoe Spark Plugs



For Ford Cars

An inexpensive plug, of good material and workmanship, that has proved satisfactory to thousands of Ford owners. An exceptional value at our special reduced price.

- D5991—1/2", price ea. (wt., 4 oz.) **.25**
- Set of 4 (wt., 1 lb.) **.....96**

Genuine Champion X Spark Plugs

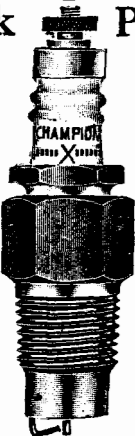

39c **39c**

Genuine Champion X plug, new extension style, used as factory equipment on Ford cars and trucks. It is a good plug for the price, but we recommend a heavier plug, such as our Western Giant, which we believe gives you much more for your money. Regular price, 60c. Shipping weight, 4 oz.

Why Pay More?

- D5975—Our Reduced Price... **.39**
- D5976—Extra Porcelains, for extension type plug, each **.....23**
- D5970—Extra porcelain for old type plug, without extension (not shown), each **.....23**

Bethlehem Spark Plugs

The Bethlehem Spark Plug is now one of the leading high-grade plugs. It is used as standard equipment on many of the finest cars, trucks and tractors. Also used for several years as factory equipment on Ford Cars and Fordson Tractors. Insulator is the famous "775" stone which has much greater heat resisting qualities than ordinary porcelain. Gives excellent service.

39c



Ship. wt. 5 oz.

- D5965—1/2-inch type, for Ford, Overland, Studebaker and all cars using regular 1/2-inch thread, also Fordson Tractor **.....39**
- D5967—3/8-inch regular type, for Studebaker Light 6 and a majority of cars and trucks **.....49**
- D5964—3/8-inch long type for Buick, Chevrolet and all cars using 3/8-inch long plug **.....49**
- D5962—Special for Dodge **.....49**
- D5966—Core, for 1/2-inch plug **28**
- D5968—Core, for 3/8-inch plug **28**

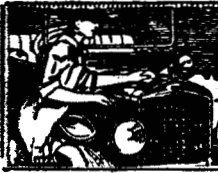

Shine Up

The "Autospra" Washing Brush

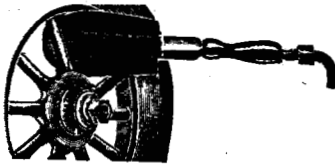

The ideal auto washer. Easy to use. Gets at the "hard to reach" places. Quickly attached to any standard hose coupling. Simple, compact, strong, durable. No loose movable parts. No set screws. The long handle gives plenty of reach. Will not scratch. Best bristles used. Length over all 17 inches. Shipping weight, 1 1/4 lbs.

G6888—Each, complete!..... **1.78**

Extra Quality Spoke Brush

A handy brush for washing spokes of wood or wire wheels or any inaccessible part of a car.



High-grade bristles and is protected at end to prevent scratching the finish. Length about 15-inches

G6904—Each (Shipping wt., 1 lb.)..... **.45**

"Utility" All-Chamois Polishers

A very serviceable, washable automobile polisher, made from all-chamois, double thickness, the pieces being sewed together with silk stitch. Gives the same service as a one-piece chamois and is used in the same manner. Ship. wt., 8 oz.

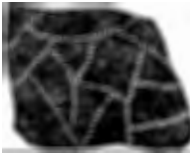

G6883—Size 13x16 in... **.29**
G6884—Size 16x21 in... **.54**

"Perfection" Wool Dusters



High grade wool dusters, excellent for automobile cleaning. Long-combed Canadian wool with black enamel hardwood handles. 10-inch handle. Wool 5 inches long. Will not scratch the finest

finish and can be washed when dirty. Ship. wt., 1 lb.
G6903—Wool Duster Our Reduced Price..... **.69**
G6905—Royal Blue Duster, extra quality, wool 9 inches long..... **1.85**

"Shino" Mitten Duster

Absorbs the dust, instead of scattering. Polishes the surface without scratching. Lessens labor and expense of many car washings. Made of heavy yarn chemically treated. Fits and protects either hand. When soiled can be washed in clear water and used again. Retains chemical properties. Saves its cost in a day and will last for months. Contains nothing injurious.



G6902—Each (Shipping weight, 1 lb.)..... **.48**

White Cotton Waste

Fine quality, long thread, white waste for cleaning and polishing auto bodies, brass or nickel trimmings.



Our Reduced Price
G6908—1 lb. **.25**
G6909—5-lb. Bag..... **1.18**
G6910—10-lb. Bag..... **2.28**

Whole Skin Chamois



These skins are tanned by a French process, which keeps them soft and pliable. Soaking in water does not injure them. Used for cleaning auto bodies or to pour over funnel for straining gasoline. Average shipping weight, 8 oz. Our Reduced Price
G6895—Chamois, about 13"x17"..... **.78**
G6896—Chamois, about 17"x23"..... **1.18**
G6894—Chamois, about 23"x26"..... **1.78**

Quality Sponges

High grade sponges, just the thing for washing and cleaning auto bodies. Shipping wt., 4 oz.

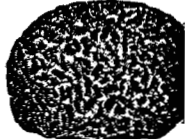

Our Reduced Price
G6898—Sponge (small)..... **.38**
G6899—Sponge (large)..... **.65**
G7002—Extra quality "Sheep's Wool" sponge, softer and much more durable. Diameter about 6 inches..... **.78**

Rubber Sponges

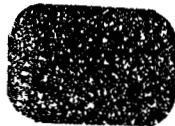

A serviceable, durable rubber sponge, about 3x5x6 inches, very handy for washing. No danger of scratching or staining surface. Ship. wt., 12 oz.

G7004—Rubber sponge, each..... **.48**

"Kant Skatch" Dust Cloths

A specially treated dust cloth, 18x27 inches, that cleans and polishes in one operation. Picks up dust without scratching surface. Can be washed without losing properties.

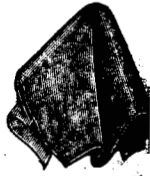

G6901—Each (Ship. wt. 4 oz.)..... **.29**
G6906—Knit-Soft Polishing Cloths (untreated), size 9x18 in. Three in box, per box (Wt., 12 oz.)... **24**

Whiz Oil Soap



An extra quality oil soap which may be used for cleaning practically anything. Especially adapted for use on automobiles. Takes off the dirt and grease and leaves a beautiful finish. Also very fine for wood work, walls, floors, furniture, dishes, linens and all fabrics and is ideal for use on the hands as it removes all dirt and grease and leaves the hands soft. Cleans and jutes nothing. Packed in no friction-top cans.

G7037—1-lb. can..... **.25**
G7038—3-lb. can..... **.75**
G7039—5-lb. can..... **1.18**

Fender Brush



A specially designed brush with metal scraper on end for cleaning mud from fenders. Extra quality white fibre bristles. Well-made and durable. Fills a long-felt want
G6846—Each (shipping weight, 1 lb.)..... **.71**

Your Car

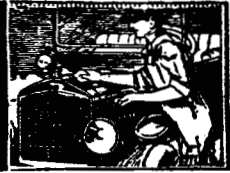

Genuine Simoniz Polish and Cleaner 44c



Simoniz is one of the best and most up-to-date cleaners and polishes on the market. It not only cleans but puts a polish on the car that stays on for some time. Not like most polishes that have to be put on every time the car is



cleaned, it will be as bright as ever with dusting off. It will remove dust, dirt and all spots, giving a bright shiny finish equal to a brand new car. Full directions on every can. Shipping weight, per can, 1 1/2 lbs.

G6881—Simon's Simoniz..... .44

G6880—Simon's Cleaner..... .44

Common-Sense Body Polish

THE POPULAR BODY POLISH FOR ALL CARS

A wonderful, greaseless polish that cleans, revives and preserves finished surfaces of automobiles, furniture, and woodwork. Will restore the high gloss to the finish of an automobile which has become dull and dingy through neglect. Removes scratches and revives life of varnishes and enamels and gives a brilliant high gloss finish. Apply with clean, soft cloth and rub briskly with soft flannel or polishing cloth. Common-Sense Polish is also an excellent Furniture Polish.



Our Reduced Price
G6877—6-oz. bottle..... .38
G6878—16-oz. bottle..... .78
G6879—32-oz. bottle..... 1.38

Metalglas Polish

FOR METAL, GLASS AND CELLULOID

A superior polish for nickel, brass and aluminum because it contains no acid or grit to scratch or injure the surface. Instead it has a vegetable oil base which prevents water, grease and dirt from sticking, and keeps surface clean and bright longer. Unequaled for glass surfaces and celluloid curtain lights. Cleans quickly, easy to use. If used regularly on nickel-plating, it will keep the surface like new indefinitely.

G6911—6 oz. can..... .23
G6912—1 lb. can..... .45



Kwik-Ak-Shun Polishing Paste

Wherever nickel or silver plating is wearing off and the brass is beginning to show through, an application of this



paste will immediately restore the original lustre to the surface. Contains no abrasive and will not injure finest surface. Cleans away the foreign matter and deposits a coat of pure nickel. Fine for reflectors, bumpers, hub caps, lamps, aluminum parts, silverware, etc. Complete with instructions.

G7023—Per Tube, (shipping weight, 6 oz.)..... .42

Steel Wool

Is used anywhere you have formerly used sandpaper. For cleaning up rough or rusted spots, before painting, it can not be equalled. Also used in household for cleaning pots and pans. (Ship. wt, 8 oz.)

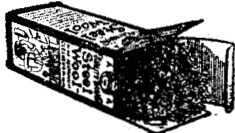

G7083—Steel Wool, per package..... 9c

Western Special Auto Polish

A polish and cleaner we can recommend as one of the most effective and easiest-used polishes on the market. Not necessary to rub hard—the polish does the work. Guaranteed to take off any mud-spot or water-spot that has not eaten through the enamel. Leaves no oil, grease or sticky substance.

G6886—16-oz. bottle..... .68



Golden Star Polish

A very popular automobile and furniture polish. Cleans, polishes and preserves the finish on motor car body, hood, fenders or top. A preventive of surface depreciation. Contains no acid, alkali, or anything that will injure the finest fabric. Needs no shaking, always ready for use. Easily applied, as hard rubbing is not necessary.

G7074—1/2-pt. can (wt., 12 oz.)..... .50
G7075—1-pt. can (wt., 1 1/2 lb.)..... .90
G7076—1-qt. can (wt., 3 lbs.)..... 1.50



Blue Ribbon Metal Polish

This well-known metal polish needs no introduction. Cleans and polishes all metal surfaces that can be polished. Handy-screw-top can prevents leakage or evaporation.

Our Reduced Price
G7063—1/2-pint size (wt., 1 lb.)..... .24
G7064—1-pint size (wt., 1 1/2 lbs.)... .42



Handy Sand Paper Assortment

An assortment of 20 sheets of sand paper 4 1/2 x 5 inches. Properly divided in five grades; very fine, fine, medium, medium coarse, and coarse. Highest quality sand paper obtainable. For use when repainting car, repairing tubes and general work about garage and home.

H7525—Assortment of 20 sheets (ship. wt., 8 oz.) .10



Emery Cloth

Good quality emery cloth in standard 9"x11" sheets. Furnished in two grades, medium fine and medium coarse.

J7730—Fine, # 1/2, per sheet .10
J7731—Coarse, # 1 1/2, per sheet .12





Saharid
FOR AUTO TOPS, ETC.

The best waterproofing we have ever found. Entirely unlike other preparations—does not contain oil, gum, varnish or shellac. Penetrates the material and renders each individual fibre water-resistant, so that the fabric remains waterproof, even if surface is worn away. Leaves material soft and pliable—will not peel off or crack. Furnished either black or colorless—black especially for auto tops that

need the stain—colorless for new tops or for use on canvas, shoes, clothing or other article you desire to make waterproof. Makes colors fast and protects them from fading—prevents mold or mildew in any climate. The effects last as long as the material itself. Fully guaranteed. Try a can of Saharid and see for yourself the wonderful results. Satisfaction or money back.

- G6922—Pint size, Black, (ship. wt. 2 lbs.)..... **.88**
- G6923—Quart size, Black, (ship. wt. 3 lbs.)..... **1.38**
- G6924—6 oz. Colorless, (ship. wt. 1 lb.)..... **.39**
- G6925—Pint size, Colorless, (ship. wt. 2 lbs.)..... **.88**
- G6926—Quart size, Colorless, (ship. wt. 3 lbs.)..... **1.38**

Top and Cushion Dressing

A liquid dressing which penetrates, softens, preserves and water-proofs auto cushions, tops and all pantsote leather and rubber goods, leaving a rich enamel finish, which is lasting; it does not form crust and crack; sun, heat or dampness do not affect it. A few hours after application, cushions can be used safely, and the dressing will not rub off or discolor garments. Any one can apply dressing by simply covering the surface with a soft brush. This dressing is thin, works into cracks and tufts, thus giving a beautiful, uniform finish.



- G6815—1-pt. Can, (Ship. wt., 2 lbs.)..... **.47**
- G6814—1-qt. Can, (Ship. wt., 3 lbs.)..... **.78**

Cylinder Enamel

A high-grade, heat resisting enamel for painting automobile motors, boilers, etc. To have your car looking its best you should paint your motor at least once a year. Our enamel is of highest quality and will hold its color under very intense heat. To apply simply clean motor with gasoline and give good coating of enamel. Furnished in two colors, black or gray.

- G7080—1/2-pt. can, black, (Ship. wt., 1 lb.)..... **.42**
- G7081—1/2-pt. can, gray, (Ship. wt., 1 lb.)..... **.48**

Primer and Filler Paint

A flat black paint for priming coat when old paint has been removed, or for filling up checks in old varnish before putting on fresh coat. Will smooth up even badly checked surfaces and enable anyone to do a first class paint job. Pint size; will cover any car case. Ship. wt., 2 lbs.



- G6842—Complete with instructions... **.49**

Whiz Hand Soap

Whiz "Menz" Hand Soap is prepared expressly for use by motorists, machinists, mechanics, painters and others, for quickly removing grease, grime and stains from the hands.

It cleans quickly and effectively, at the same time healing and softening the skin. Will not chap or roughen the hands. Also excellent for general use around the house.

- G7095—Per can (Ship. wt., 1 lb.)..... **.10**

Neatsfoot Compound

For oiling, softening and preserving all articles of leather. Composed of pure Neatsfoot oil and other leather softening ingredients. Ideal for use on clutches and belts and any leather which you wish to preserve as it restores the animal oil lost through evaporation and keeps the leather in good condition. Shipping weight, 1 lb.



Rubber Coat Gum Surfacing
For Auto Tops



58¢

Will make practically a new top out of any old pantsote or rubber, by gum surfacing it with elastic coating that makes the old top resemble a new expensive leather one. It is more elastic than leather and freeing, sun-baking or soaking will not affect elasticity or finish.

A 1-pint can is enough to put one coat on a touring car top, giving it a good dressing and a new appearance but to gum-surface the top (requiring two coats) you must have a quart can. The pint can will gum-surface a runabout top. Also very fine for sedan and coupe tops.

- G6831—1-pt. Can. (Ship. wt., 2 lbs.).....
- G6830—1-qt. Can. (Ship. wt., 3 lbs.).....

AIR-DRYING ENAMELS

Black Enamel

Our Black Enamel is for lamps, radiators and other metal parts of the car. Gives a nice smooth enamel finish that will not crack or peel. Can also be used to fill cracks or cover chipped places on body or fenders. Dries quickly and will not chip off. Is not affected by hot or cold weather.



Gray Enamel

A high quality gray enamel for use on running gear frame parts, or in fact almost any part of the car.

Aluminum Enamel

Used on cylinder block, muffler, exhaust pipe and other parts where extreme heat must be withstood.

- G6854—Black Enamel, 1/4 pt. (Ship. wt., 8 oz.)..... **.32**
- G6855—Black Enamel, 1/2 pt. (Ship. wt., 1 lb.)..... **.38**
- G6856—Black Enamel, 1 pt. (Ship. wt., 2 lbs.)..... **.64**
- G6848—Gray Enamel, 1/2 pt. (Ship. wt., 1 lb.)..... **.41**
- G6852—Aluminum Enamel, 1/2 pt. (Ship. wt., 1 lb.)..... **.34**

Mohair Dressing

Made of scientifically prepared chemicals and is one of the finest top dressings made. It gives a new bright black finish to mohair and all cloth tops and seat covers. Will not crack, fade or rub off on clothing. Waterproofs and preserves the top. It should be used on all mohair tops frequently.

- G6819—1-pt. can, (Shipping weight, 2 lbs.)..... **.48**
- G6818—1-qt. can, (Shipping weight, 3 lbs.)..... **.79**



Rim Paint

Prevents rust, which spots inner tubes and sticks casings to rim. Makes tire changing easy, prevents tearing tube when removing it and adds many months to the life of the tube. Put up in 1/2-pint cans—enough for four small rims or two large rims. Shipping weight, 1 lb.

- G6844—1/2-pt. Can..... **.21**

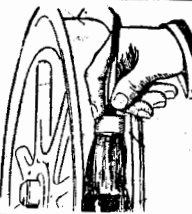

Western Waterproofing Compound

Made by one of the largest manufacturers of tents in the United States by the same formula used on all their water-proof tents. When properly applied, is guaranteed to turn water, no matter how long or hard it rains. One gallon will cover about 100 square feet of canvas surface. Comes ready for use, with full instructions. Shipping weight, 10 lbs.

- G7024—One gallon clear..... **1.85**



Refinish Your Own Car

Western Painting and Refinishing Outfit.



You can go over your entire car with this outfit in a short time and have it looking just like new. No experience necessary. Complete printed instructions and all necessary material packed in a substantial box. Best quality materials, all ready mixed for use. No delay, no waste just the amount needed for a Ford, Maxwell, Chevrolet or other small car. A dependable outfit that will give you a serviceable job. Consists of

- 1-quart can of Auto Body Enamel, Gloss Black.
 - 1-pint can of Running Gear Paint, Gloss Black.
 - 1/2-pint can of Engine Enamel, Gloss Black.
 - 1/2-pint can of Lamp and Trimming Enamel, Gloss Black.
 - 1-quart can of Leatheroid Dressing for Top and Cushions.
 - 2 Varnish Brushes, Sandpaper, Steel Wool, and Waste.
- G6845—Complete with instructions (wt. 10 lbs.) 3.95**

Lining Dye



Will dye the lining of any old top a perfectly even color, eliminating every spot, faded or dirty streak, at one application with a sponge, without removing the top. It is insoluble in water and cannot possibly soak up, rub off or run when the top is wet. It will not injure the fabric or fade more than new cloth would. It merely dyes the cloth like new, without changing it in any other respect. Drab dye is fine for renewing color of Khaki tops.

Pint size for roadster tops, quart for touring cars.

- G6836—Pint can, Black Dye..... Wt., 2 lbs. **.46**
- G6835—Quart can, Black Dye..... Wt., 3 lbs. **.85**
- G6838—Pint can, Drab Dye. Wt., 2 lbs. **.80**
- G6839—Quart can, Drab Dye..... Wt., 3 lbs. **1.35**

Varnish Brushes

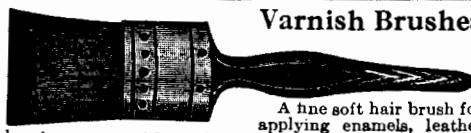

A fine soft hair brush for applying enamels, leather dressing or varnish. Shipping weight, 8 oz.

- G6860—Varnish Brush, 1 inch wide **.16**
- G6859—Varnish Brush, 2 inches wide **.27**
- G6858—Varnish Brush, 3 inches wide **.52**

REFINISHING BRUSHES—EXTRA QUALITY

- Extra fine brushes, vulcanized in rubber, for refinishing work.
- G7060—Extra Quality, 1-in. **.38**
- G7061—Extra Quality, 2-in. **.68**
- G7062—Extra Quality, 3-in. **1.19**

"New Shine" Refinishing Outfit

Especially recommended for the car owner who wants to improve the appearance of his car at small cost, and without having the time to do a more complete and thorough job with our "Western" outfit. Contains enough paint and top dressing to go over a Ford or other small car once. Dries quickly and wears well. Also includes two paint brushes, a package of steel wool waste, and full instructions.



B5473—Outfit complete (shipping weight, 5 lbs.) 2.35

Western Auto Finishes



A very high grade finish, especially prepared for auto bodies, fenders, wheels, etc. With our variety of colors you can have almost any combination you want. We recommend the white, red or yellow for wheels; the black, green or blue for body; the black or gray for axles, springs and running gears. If you are undecided about the colors you want, write us for card of sample colors. Ship. weight, quart 3 lbs., pint 2 lbs.

PINTS		QUARTS		
G7065	.59	Black	G6800	.98
G7067	.78	Dark Green	G6802	1.45
G7071	.78	Gray	G6806	1.45
G7069	.88	Yellow	G6804	1.60
G7066	.88	Dark Blue	G6801	1.60
G7068	.88	Maroon Red	G6803	1.60
G7070	.88	White (wheel paint)	G6805	1.60

Clear Auto Varnish



A pure colorless varnish which adds depth and richness to the color and produces that luxurious bright appearance seen on high-priced cars.

When only the finish on a car has become dull—and the base color is still in good condition—a coat of Clear Auto Varnish will restore the original bright new luster.

- G6811—1-pt. Can, (wt., 2 lbs.) . **.62**
- G6810—1-qt. Can, (wt., 3 lbs.) **1.10**

Paint Remover

If the paint on your car is bad, it will usually pay you to use a paint remover like the paint shops. This entirely removes all paint, varnish, etc., and leaves a clean surface upon which to build up the new finish.

- G7085—Paint Remover, pint, (Ship. wt., 1 1/2 lbs.) **.42**
- G7086—Paint Remover, quart, (Ship. wt., 3 lbs.) **.72**



Genuine Columbia Hot Shot Battery

The Battery with the Steel Jacket



Our
Reduced
Price
\$1.89

Make your Ford easy to start with a Columbia Hot Shot Battery. No use to break your back and blister your hands by hard cranking. The Hot Shot has taken the place of the old, cumbersome bundle of dry cells bound together with a string. The Hot Shot consists of four genuine dry cells properly connected, embedded into a solid moisture-proof unit enclosed in a steel jacket—just the right size to fit out of the way, down along side the gas tank. No possible chance of short circuits or loose connections. Only two connections to make. Gives batteries longer life on account of the protection. Can also be used for lighting of tail light. A necessity for Ford cars. Also makes an excellent emergency light—an extension cord puts the light where you need it in changing tires, etc., at night. Shipping weight, about 10 lbs.

C5706—Our Reduced Price—Complete..... **1.89**



Genuine Columbia Dry Batteries

We handle only standard, well known brands of dry cells in large quantities, so we are buying constantly, therefore always have fresh stock. We do not handle any cheap off-brand batteries as they are not satisfactory. The best is always the cheapest. Fresh new stock. Weight 4 lbs. each.

C5704—Our Reduced Price..... **.37**

Security Battery Connections



This connection cannot come loose, even if the nut comes off. Shipping weight, dozen, 8 oz.

C5645—Security Connection, each..... **4c**



Copper Terminals

Made so they can be easily and permanently attached to wire cable without solder.

Shipping weight, dozen, 4 oz. Price Per Doz.

C5641—For Primary or Lighting Cable..... **.12**

C5640—For High-Tension Cable..... **.15**

Grip-tite Battery Clips

High grade clips for use in charging batteries. Make good temporary connection. Made of steel, lead coated to prevent deterioration from acid fumes. Fit any battery. Ship. wt., 4 oz.

C5642—Each..... **.14**

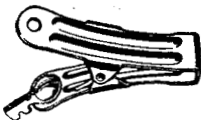

Solderless Battery Terminals



Not plated, but made of non-corrosive material all the way through. Absolutely will not corrode or stick to battery post. Tensile strength is greater than brass. No soldering required to attach to cable. Anyone can do it. Simply peel back the insulating material, twist it into tapering opening of terminal and tighten set screw. Makes perfect connection. Satisfaction guaranteed. For standard size cable. Ship. wt. 8 oz.

B5488—Positive terminal..... **.35**

B5489—Negative terminal..... **.35**

Dashboard Ammeter

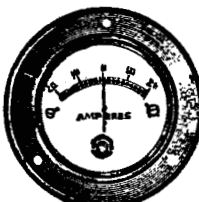

Is especially designed so that it may be left in circuit permanently. The moving parts are few and light, so that any amount of jarring does not appreciably affect the points of the pivots to cause friction at the bearings. These two features adapt this meter especially to automobile use.

Case of meter is made of brass, handsome black finish.

Meter is fitted with back connection bolts, about 1 1/2 inches long, so that they may be attached to the dash and wired on the enclosed side of the board, thus making a neat appearance. Scaled 0 in center and shows charge or discharge up to 20 amperes for Ford cars, 30 amp. for others.

C5714—Ammeter for Ford cars, (wt. 12 oz.)..... **.62**

C5715—For any other car. (ship wt. 12 oz.)..... **.78**

Pocket Ammeters and Volt-meters

Good dry batteries are frequently thrown away because of one weak cell. The owner of a pocket ammeter is enabled to know in a moment the exact strength of the cell he is buying, just when to discard a cell, and just when his battery needs complete renewal. Also very fine for radio use. Thoroughly reliable, and warranted to read correctly under all conditions. Handsome nickel plated brass case. Shipping weight, 8 oz.

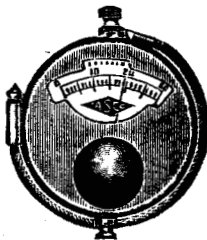

C5711—Ammeter for Dry Cells only..... **.58**

C5712—Combination Volt-Ammeter for testing voltage up to 8 as well as amperage up to 35..... **.88**

C5713—Volt-meter only, for Radio B Batteries, tests up to 30 volts..... **1.65**

Battery Hold Down Clips



Exactly replace the hold-down clips on the present Ford battery. Strongly made and guaranteed to fit. Better get an extra set to carry for an emergency as clips are easily lost. Shipping weight, per set, 4 oz.

B5303—Our Reduced Price, Each, **8c**; Pair..... **.15**

K-E-M Terminals

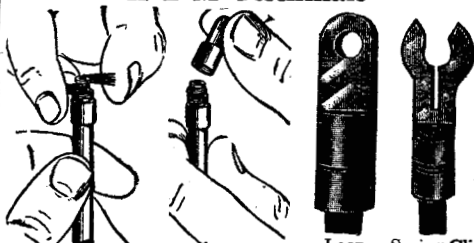

At last a perfect terminal. Can be used on all ignition wires on any car. Wires are wrapped around head of terminal and cap screwed on so that it makes a permanent, non-loosening contact that will never pull out. Made of brass to allow good flow of current. Come in clip type, as illustrated at right, and loop type. Sizes shown represent opening in terminal where wire is inserted. Ship. wt., 1 oz.

C5645—Loop Type for Primary Low Tension Wire..... **9c**

C5647—Loop Type for Secondary High Tension Wire..... **9c**

C5648—Spring Clip Type for High Tension Wire..... **9c**

Storage Battery Terminals

A high grade, heavy terminal for replacement on Ford cars with starter. Also fit Chevrolet Superior, and 490, (since 1919) and any other car with the same style of battery posts. Lead coated to prevent corrosion. Complete with bolt and nut. Shipping weight, each 4 oz.

B5493—Positive terminal, each..... **.16**

B5494—Negative terminal, each..... **.16**



The "Homcharger" for Storage Batteries

KEEP YOUR BATTERY PROPERLY CHARGED
SAVE TIME AND MONEY

Complete **\$13.65**



Everyone knows that a storage battery deteriorates unless it is kept properly charged. With a "Homcharger" you can now save all of the expense, inconvenience and delay of having to take your battery to a service station. Simply attach the charger to your battery with the clips furnished, then insert the plug in any electric light socket. It charges automatically at the proper rate and cuts off automatically when the proper charge is reached. No danger of injuring battery. No wasted current. Will fully charge any 6-volt battery at a cost of from 4 to 10 cents.

Fully charged batteries do not freeze. They give better service and last longer, and are always ready for use; start the car quickly in the coldest weather. By keeping your battery always in condition, the "Homcharger" will soon pay for itself. Works equally well on radio batteries. Comes complete ready for use, with full instructions.

Shipping weight, 15 lbs. (Regular list price \$18.50.)

C5920—Complete outfit for any 6-volt battery for use with any regular 110-volt 60-cycle alternating current..... **13.65**

C5934—"Homcharger" for use with other types of electric current, direct or alternating, or for charging 12-volt batteries. Be sure to specify voltage of battery, voltage and cycle of current and whether direct or alternating. (Shipped direct from factory in Ohio) **13.65**

For Automobile or Radio Batteries

Work-Rite Hydrometer

Makes It Easy to Keep Your Battery In Shape



A hydrometer is an inexpensive protection against storage battery trouble due to lack of proper or systematic inspection. You should test your battery at regular intervals with a reliable hydrometer. Used to test the strength of the acid solution (specific gravity) in battery cells, also to add distilled water to cells when necessary. Always keep solution slightly above top of battery plates to avoid danger of ruining plates.

Workrite Hydrometer outfit complete with battery jar filler, making a very handy combination. The round rubber collar of the hydrometer makes a very practical stopper for the 1-quart jar. Keep the jar filled with distilled water, thus insuring having a supply always on hand and keeping the instrument clean. Jar has a label

with instructions for testing strength of acid in battery cells and spaces for filling in dates of filling or testing. Works equally well for automobile and radio batteries. Outfit complete, carefully packed. Shipping weight, about 2½ lbs.

Our Reduced Price

C5720—One quart size..... **.98**

Perfect Test Hydrometer



The newest and best hydrometer on the market. Glass points on float prevent sticking to sides and allow a clear accurate reading. Rubber shoulders protect glass when laid down. Construction of bulb and tip make it airtight and leak proof.

Every battery owner should have a hydrometer in order to take proper care of his battery and improve its service as well as lengthen its life. The Perfect Test Hydrometer meets all requirements for automobile or radio battery use and is "always on the job." Comes carefully packed. Shipping weight 1 lb. Our Reduced Price

C5726—Hydrometer Complete..... **.68**

Battery Box for Running Boards

KEEPS BATTERY IN MOST CONVENIENT PLACE



Lets you keep your battery on the running board of your car, where it is easy to get at for testing and filling. Protects battery from wet and dirt; lengthens its life. Box is made of best 20-gauge steel, finished in black enamel. Has olefin back for battery cables to enter. Bolts to running board, will not rattle or shake loose. Shipping weight, 8 lbs.

W8343—10" long by 8" wide by 10½" high (Ford size) **1.95**

Wizard Radio Batteries

Here is a storage battery built especially for radio service. Extra thick plates and highest grade insulation, assuring high ampere-hour capacity and longer life. Strong, neat, well-made wood box. Highest grade rubber jars, tested under 20,000 volts, giving absolute protection against leakage. Handy screw-on type of terminals for quick and easy connection. Shipped fully charged in strong wood case direct from our stores.



Cannot be sent by mail.

X8593—Radio Battery, 6-volt, 100 amp. (wt., 45 lbs.)..... **12.65**

X8594—Radio Battery, 6-volt, 150 amp. (wt., 65 lbs.)..... **16.65**

Break-Not Hydrometer



BATTERY TESTER

Improved construction eliminates breakage to a large extent. Special acid-proof rubber tip. Bulb made of red rubber. Hydrometer float has a large, clear scale, which is easily read, indicating charging points and battery condition. For all automobile and radio "A" batteries.

C5717—Each, complete (shipping weight, 1 lb.)... **.78**

Battery Syringe Hydrometer



Used for testing acid in automobile or radio storage batteries. Accurate, carefully packed, large capacity. Full instructions for using with each outfit. Ship. wt. 8 oz.

Our Reduced Price

C5723—Hydrometer, complete with float..... **.42**

C5725—Hydrometer Float only, in wood case. **.19**

Battery Filler

60c



Lets you fill your storage battery without wasting water or losing time. Bulb is 3" in diameter; holds enough water for several cells. Length over all, 10 inches. Ship. wt., 1 lb.

C5716—Battery Filler, each..... **.60**

X8148—Battery Filler with Battery Syringe Hydrometer, shown above, set..... **.95**

Wizard Battery

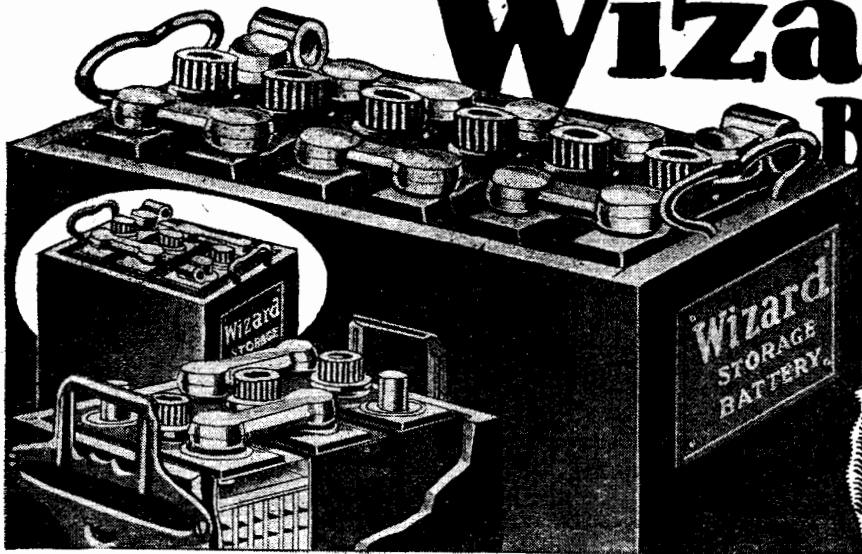

60 DAYS TRIAL IN YOUR OWN CAR

Thousands of Wizard Storage Batteries are now in daily use. They have been used under all conditions in all makes of cars and have stood up under every possible test. From actual records over years of service we know of no better battery made, regardless of name or price.

SELECTED MATERIALS

Wizard Storage Batteries are built by reliable manufacturers of long experience. The very best materials are used throughout—high-grade red lead and litharge for the oxides, antimonial lead grids to prevent buckling, tongue-grooved kiln-dried box, extra thick, long-lived plates, burned-on terminals—assuring a high-grade, dependable battery for every purpose.

SCIENTIFIC CONSTRUCTION

The jars are made of the finest grade hard rubber, and each one is tested under high electric voltage to avoid the possibility of using an imperfect jar which might leak current. A heavy hard-rubber cover, with a shoulder designed to fasten securely to the jars, prevents the acid solution from seeping through the cover or around the terminal post, thus eliminating corrosion and its troubles.

The separators are best-grade re-sawed white cedar, and not the cheap veneer variety so commonly used. They

60 DAYS TRIAL IN YOUR OWN CAR

Send us your order for a Wizard Storage Battery. When it comes, put it in your own car and use it for 60 days. Test it out thoroughly. Then if for any reason you are not satisfied or feel that the Wizard is not equal in every way to any battery on the market, regardless of name or price, write us for shipping instructions; we will refund your money and all transportation charges.

are thoroughly treated and cured, so they allow the current to flow freely, yet give complete insulation, preventing short circuits.

MADE FOR ALL CARS

We furnish Wizard Batteries for any car, duplicating your present battery as to voltage, terminals, size, shape, etc. The list at the bottom of this page shows most of the popular cars. If your car is not listed, write us for price. On all orders where correct information is given as to year and model of car, we absolutely guarantee

Car	Year	Model	Wood Box Price	Rubber Case Price	Car	Year	Model	Wood Box Price	Rubber Case Price
Allen	1916-20	37, 41	1 3/4	2 1/2	Essex	1919-24	All	1 3/4	2 1/2
Allen	1921-22	All	1 3/4	2 1/2	Ford	For reg. Ford starter		1 3/4	2 1/2
Auburn	1919-21	6-30, H, K, R	1 3/4	2 1/2	Franklin	1916-20	All	1 3/4	2 1/2
Briscoe	1917-22	All	1 3/4	2 1/2	Franklin	1921-22	All	1 3/4	2 1/2
Buick	1917-18	All	1 3/4	2 1/2	Franklin	1923-24	All	1 3/4	2 1/2
Buick	1919-22	All	1 3/4	2 1/2	Grant	1917-18	K, G	1 3/4	2 1/2
Buick	1923	All Fours	1 3/4	2 1/2	Grant	1919-23	All	1 3/4	2 1/2
Buick	1923-24	All Sixes	1 3/4	2 1/2	Gray	1922-24	All	1 3/4	2 1/2
Cadillac	1914-24	All	1 3/4	2 1/2	Haynes	1921-24	All	1 3/4	2 1/2
Case	1918-21	All	1 3/4	2 1/2	Hudson	1915-24	All	1 3/4	2 1/2
Chalmers	1919-23	All	1 3/4	2 1/2	Hupmobile	1918-21	All	1 3/4	2 1/2
Chandler	1917-18	First 24,000	1 3/4	2 1/2	Hupmobile	1922-24	All	1 3/4	2 1/2
Chandler	1919-24	All	1 3/4	2 1/2	Jordan	1916-24	All	1 3/4	2 1/2
Chevrolet	1916-24	490, Supr.	1 3/4	2 1/2	Lexington	1919-24	All	1 3/4	2 1/2
Chevrolet	1918	D-4, D-5	1 3/4	2 1/2	Lincoln	1920-24	All	1 3/4	2 1/2
Chevrolet	1919-22	FB, T	1 3/4	2 1/2	Marmon	1918-24	34, B-34	1 3/4	2 1/2
Cleveland	1919-24	All	1 3/4	2 1/2	Maxwell	1915-20	(12-volt)	1 3/4	2 1/2
Cole	1915-19	All	1 3/4	2 1/2	Maxwell	1920-22	(6-volt)	1 3/4	2 1/2
Cole	1920-24	All	1 3/4	2 1/2	Mitchell	1917-23	All	1 3/4	2 1/2
Dodge	1915-24	All	1 3/4	2 1/2	Moon	1918-24	All	1 3/4	2 1/2
Dort	1916-24	All	1 3/4	2 1/2	Nash	1917-18	681, 682	1 3/4	2 1/2
Durant	1922-24	All Fours	1 3/4	2 1/2	Nash	1919-24	All	1 3/4	2 1/2
Durant	1922-24	All Sixes	1 3/4	2 1/2	Oakland	1917-19	All except 50	1 3/4	2 1/2
Elcar	1918-23	All	1 3/4	2 1/2	Oakland	1920-24	All	1 3/4	2 1/2
Elgin	1918-23	All	1 3/4	2 1/2	Oldsmobile	1916-20	All	1 3/4	2 1/2

Storage Series

95
UP



CAR—GUARANTEED 18 MONTHS

GUARANTEED 18 MONTHS

Every Wizard Battery is thoroughly tested and inspected. It will respond instantly to your touch on the starting pedal and spin your motor with great force. It will furnish your plugs a powerful spark and give your lamps a strong, bright light.

Every battery is guaranteed for 18 months (Fords, one year) against defects of workmanship or materials. If a Wizard Battery develops trouble due to any defects within 18 months (one year for Fords), we will repair it free of charge or replace it on a service basis.

furnish the proper size and exact voltage of the battery to be replaced.

WIZARD RUBBER-CASE BATTERIES

Solid rubber case batteries are the latest development in battery construction. The rubber case and jar compartments are all moulded in one solid piece. This does away with leaky cells, and makes a battery that is almost unbreakable. This solid construction also makes it absolutely waterproof, so that no damage can be done by mud, water or oil or even the stones and other small objects

sometimes thrown up from the road. We can furnish Wizard Batteries with rubber case for almost any car.

SHIPPED FULLY CHARGED READY FOR USE

All batteries are fully charged before shipping, then carefully packed in a strong wood case, so that the battery will reach you in perfect condition, ready for immediate use. Prompt shipments direct from our stores, ensuring quick delivery and smaller transportation charges. Because of postal regulations, batteries cannot be sent by mail. Average shipping weight, 60 lbs.

WHY PAY MORE THAN OUR PRICE?

On account of our enormous buying power and direct-from-factory-to-car-owner system of distribution we are able to reduce the cost of Wizard Storage Batteries to the lowest possible cent. Why pay the jobber, salesman and service station each a profit, when you can buy a Wizard Guaranteed Storage Battery at a saving of from \$3.00 to \$15.00, with the privilege of 60 days' trial in your own car? Shipped anywhere C.O.D. without deposit if desired.

Car	Year	Model	Wood Box Price	Rubber Case Price
Oldsmobile	1921-24	All	13.35	15.35
Overland	1915-18	.81, 83, 83B, O. E. 85, 85-6, 86	13.35	
Overland	1916-21	.75, 75B, 90, 90B, 4	11.35	12.85
Overland	1916-18	.84, 88, 88B	10.95	10.95
Overland	1920-24	All except 20	15.35	15.35
Packard	1916-21	All except 6	15.35	15.35
Paige	1916-22	All	15.35	15.35
Peerless	1917-22	All	15.35	15.35
Reo	1916-24	All	15.35	15.35
Saxon	1917-19	All	15.35	15.35
Saxon	1920-23	All	15.35	15.35
Star	1922-24	All	15.35	15.35
Studebaker	1916-21	All except E.J.	15.35	15.35
Studebaker	1921-23	EJ & Light 6	15.35	15.35
Velie	1918-22	.38, 6-34, 58	15.35	15.35
Velie	1917-22	.27, 37, 39, 6-48, 48	15.35	15.35
Westcott	1914-24	All	15.35	15.35
Willys-Knt	1916-19	All	16.65	
Willys-Knt	1920-24	All	19.35	

If your car is not shown write for price

Wizard Batteries for Ford Cars \$95



Wizard Batteries for Ford cars are built of the highest grade material and by the most scientific processes. Guaranteed one year against defects. Privilege of 60 days' trial in your own car. Shipped fully charged, ready for use. Shipping weight, 50 lbs.

X8585—Regular wood case 9.95
X8586—Solid rubber case 10.95

Apco Oil Gauge
For Ford and Chevrolet Cars

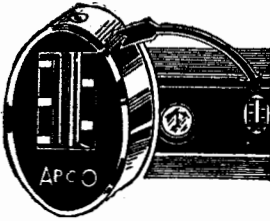

Fits right on the instrument board where you can see at a glance the condition of your oil supply. No need to get all dirty and greasy opening a drain cock or trying to see the oil level in a dirty gauge way under the car. Lets you keep the oil at the proper level, without guessing. Will pay for itself in saving of oil alone.

Substantially made of aluminum with a hollow wire leading to an air pressure chamber, which is threaded in the lower pet-cock hole of the car. The fluid in the gauge rises or falls with the variation of air pressure in the tube, through which no oil or liquid passes.

Attractive in appearance. Can be installed in 15 minutes. Absolutely nothing to get out of order. Complete satisfaction guaranteed. Shipping weight, 2 lbs.

- D6236—Complete for Ford cars 1.95
- D6253—Complete for Chevrolet "490" or "Superior" 1.95

Dash Oil Gauge

FOR POPULAR CARS

A replacement dash oil gauge for use on almost any make of car. Two inches in diameter, with extra ring for use on wooden dashboards. Handsome silvered dial. Shows oil pressure up to 25 lbs. Well made and accurate; fully guaranteed. Complete with clamp and nut for attaching to dash.

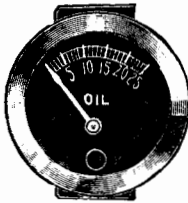

Our Reduced Price

- J7701—Complete..... 1.78

Plain Grease Cup

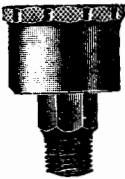

These grease cups are finely made of steel. The ledge on the cap and milled edge insure firm grip. Caps fit perfectly, making leakage of grease impossible.

Special Extra Large Grease Cups for Ford rear axle are much better than the smaller ones which come on the car, as they do not have to be filled so often and provide plenty of grease for the bearings. Shipping weight, 2 oz.

- G7015— $\frac{3}{4}$ " , $\frac{1}{8}$ " pipe thread (fits Ford spring shackles), each..... 6c
- Set of 8..... .42
- G7014—1" , $\frac{1}{8}$ " pipe thread (fits Ford rear axle), each..... 9c
- G7013—1 $\frac{1}{2}$ " , $\frac{1}{4}$ " pipe thread (drive shaft), each. .12

Clean-Easy Magneto Plug
For Ford Cars and Fordson Tractors

Once installed, is as easily removed for inspection or cleaning as a spark plug. Has threaded washer which is fastened in place with the regular three magneto contact screws; then the plug screws down into this, with copper asbestos gasket to prevent leakage. When screwed down against the field coil, the fiber shoulder comes down and covers up the contact point, keeping the point clean, giving a better contact, and making the engine start easier and hit better. Made of best quality materials. Easily installed by any one; full instructions furnished. Shipping weight, 4 oz.



- B5316—Clean-Easy Magneto plug, complete..... .82

Apco Oiling System for Ford Cars

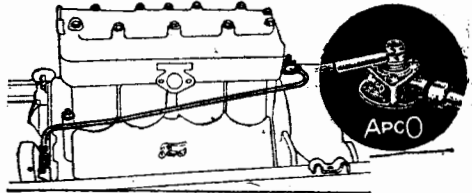

This is a force feed oiler which collects oil through a special magneto post with an opening to catch the oil thrown up by the fly wheel. The oil then flows through a pipe on the left side of the engine to a hollow bolt which replaces one of the front crank case bolts.

The magneto plug is kept clean by the force of the oil thrown up against it, and the pressure makes the pipe clog-proof.

Requires no drilling or special tools and can be put on in a few minutes. Will deliver more oil going up hill than on level roads. Keeps the engine cool and prevents burning out of bearings from clogging of the regular Ford oil line.

Well made of best materials. Nothing to get out of order. Will last life of car. Regular price \$2.50. Wt. 2 lbs. D6251—Oiling system complete, with full instructions. 1.68

"Jumbo" Oil Cups

Hold a big supply of oil and are preferred by many motorists. The spring lid keeps out dirt. Size of body $\frac{3}{4}$ " diameter. Plain steel finish. Shipping weight, 4 oz.



- G7001—Elbow type, for spring shackles and horizontal openings, ea. .18
- G7000—Straight type, for spindle bolts and perpendicular openings..... .14

Choker Wire and Carburetor Spring
FOR FORD CARS



A combined Choker Wire and Carburetor Spring, which works perfectly on all Ford cars, whether choked from the dash or from the radiator. Easily installed by anyone; will outlast your car. Put one on your Ford while it is new, and you will never have a flooded carburetor.

- E6305—Complete (ship. wt., 12 oz.)..... .20

Carburetor Choker Spring

An efficient, easily installed spring to hold the carburetor choker in proper position when the regular spring is broken. Has the proper tension and will last indefinitely. Can be installed in less than a minute, without use of tools. Cannot work loose. Ship. wt., 4 oz. E6302—Each..... 8c

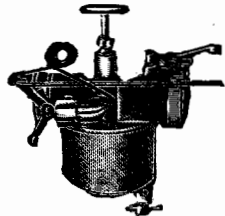

Security Choke-Hold
FOR FORD CARS



A real necessity for the Ford car. Consists of a plate which fastens to the dash under the hood with a clamp and two springs which serve to hold the choke rod where you set it. By leaving the choke closed until the motor worms up you save frequent re-starting, which saves battery current or muscle-power. Quickly and easily installed. Nothing to get out of order—will last as long as your car. Ship. wt., 12 oz.

- C5566—Complete..... .38

Kant Leak Grease Retainer

FOR FORD CARS

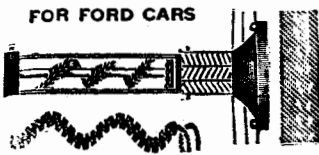

A new improved grease retainer which consists of a spiral of heavy wire studded with stiff bristles. It slips over the rear axle, so that with every revolution of the axle the grease is brushed back toward the differential. A fiber washer fits just inside the roller bearing to prevent the grease from escaping when the car is not in motion. By using bristles in this way, it is possible to get a retainer which will pass readily through the small opening at the end of the housing, then spring back so as actually to touch the inner walls of the housing and keep all grease from getting by. Easily installed and will last indefinitely. Satisfaction guaranteed.

C5858—Pair, complete (ship. wt., 1 lb.)..... **1.35**

F-B Oil Saver



Replaces regular cap on oil filling pipe. Keeps all dirt, dust and moisture out of oil, which means improved lubrication and fewer troubles. Absolutely prevents oil leaks through gaskets, around spark plugs, etc. Stops oil-pumping past pistons, reduces carbon, keeps spark plugs from fouling. Has been thoroughly tested; satisfaction guaranteed or purchase price refunded.

Will soon pay for itself in saving of oil alone. Ship. wt. 12 oz.
E6304—Our Reduced Price each..... **.85**

Oil Can Holder

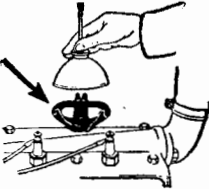

This holder fastens to cylinder head bolt, so that your oil can is always easily reached by raising hood. Made of steel. Absolutely will not rattle or work loose. Ship. wt., 8 oz.

Our Reduced Price

G6976—Each..... **.19**

Oil Cans

Made of steel, copper plated. Very durable. Av. shipping wt., 8 oz.

G6964—Reg. Ford size, 3 1/2-in. diameter, 1/2-pint..... **.19**

G6965—1/2 Pint with 5-in. spout..... **.26**

G6966—1/2 Pint, with 9-in. curved spout. Not illustrated..... **.32**

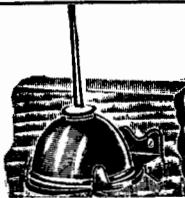

Flexible Spout Oiler

One of the handiest oil cans made. Has a strong 7-inch flexible spout that can be easily bent to almost any angle, so as to get around any obstructions or out of the way places in oiling an automobile. Saves time and work. A durable, standard can 3 1/2 inches in diameter. Made of steel, nicely copper plated. Shipping weight, 8 oz.

G6969—Our Reduced Price..... **.42**



Three-In-One Oil

Three-in-One Oil is one of the oldest and best-known oils on the market. Is highly refined from the very best materials and is guaranteed to give best results. Especially recommended for magneto bearings and timers, and is also good for bicycles, sewing machines, guns and many other uses. Comes in handy can with capped spout, to prevent spilling if upset. Contains 3 oz. oil. Shipping weight per can, 8 oz.

G6958—Our Reduced Price per can **.28**

Trautner Grease Retainer for Ford Cars and Trucks

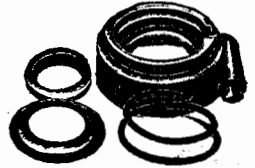
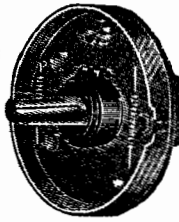

The best grease retainer ever made for a Ford. Easy to put on without getting all covered with grease and without having to pull out the bearings. Retainer replaces the dust cap and felt washer right next to the hub. Has an asbestos packing ring that clamps around the axle shaft, with a beveled steel washer and spring that keep the asbestos ring tight, no matter how badly the roller bearings are worn.

Nothing to wear out, except the asbestos packing ring, which will last for months and can then be easily replaced at small cost. Full instructions furnished. Satisfaction guaranteed. Shipping weight, 1 lb.

J7756—Complete retainer, for Ford cars, each.... **.85**

J7757—Extra packing rings, for Ford, each..... **.20**

J7750—Comp. retainer for Ford Ton Truck, similar to J7756, but with leather non-removable washer (not illustrated), each..... **.85**

"SHUR-NUFF" Grease Retainer

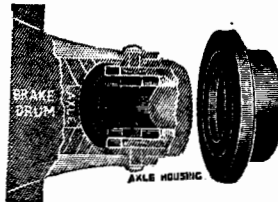

You know that grease leaking from the rear axle housing costs you money, rots your tires, and makes an unsightly mess on the wheels. Also, brakes hold better when not flooded with grease. You can stop it effectively with a Shur-nuff Grease Retainer. Not an ordinary felt washer which soon needs

replacing, but a patented retainer consisting of three extra high grade felt washers, one rubber composition washer, steel cup and retaining rings. When assembled, as shown in cut, it is a most effective and lasting way of stopping grease leaks. Shipping wt., 1 lb.

J7758—Shur-nuff Set, for one side only..... **.60**

Complete Set, both wheels..... **1.12**

Power-King Muffler for Ford Cars

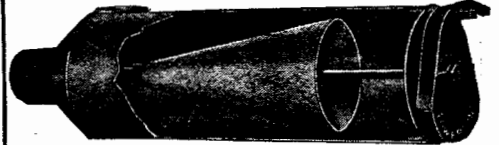

The Power-King Muffler is designed and built on the well-known principle of one sound wave counteracting the other. Reduces noise to the minimum, making a very quiet muffler, and also reducing back pressure to the minimum. Note the complete absence of all pressure chambers, tubes and baffle plates. Observe the free, unobstructed and easy path for the gases. Nothing to clog up or get out of order.

Many users are getting from three to five more miles from every gallon of fuel with the use of a Power-King muffler. Substantially made and easy to install. Remove old muffler and slip the new one right on, using same bolts. Shipping weight about 8 lbs.

B5469—Our Reduced Price Complete..... **1.65**

Exhaust Deflector for Ford Cars

This article clamps on end of muffler and is easily turned in any direction. It is especially desirable for deflecting oil, heat or smoke from tires when carried in rear. Does not interfere with exhaust in any way. Fits both closed and open cars. Finished in black enamel. Shipping weight, 8 oz.



D6008—For 1918-1920 models, bottom opening.... **.14**

D6009—For 1921-23 models with side opening..... **.19**



Graphite Greases

Our graphite greases are prepared by special process by one of the largest refineries of grease in the world. Base is best quality grease and the graphite used is the finest that money can buy. This kind of grease is really the cheapest kind to buy, as it goes much farther and saves your car by reducing friction on bearings and bolts.

- G7046—1-lb. can Graphite Cup Grease **.22**
- G7048—3-lb. can Graphite Gear Grease for Differentials and Transmissions..... **.72**
- G7047—5-lb. can Graphite Gear Grease for Differentials and Transmissions..... **.98**

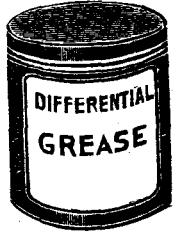

Differential Grease

A high quality plain non-fluid oil, especially designed for use in automobile differentials.

Lubricates efficiently under all service conditions and during all seasons, as it is not affected by extremes of heat or cold. Comes only in 5 and 10-lb. cans.

Our Reduced Price

- G6960—5-lb. can **.72**
- G6962—10-lb. can **1.28**

Flake Graphite



Very fine flake graphite for mixing with lubricating oil or grease, making it last longer and lubricate more efficiently. Forms a thin, smooth, durable coating on bearings and prevents wear and noise.

- G6955—1/4-lb. can **.19**
- G6954—1/2-lb. can **.35**
- G6953—1-lb. can **.68**



Fine Parts Oil

A very-high grade, thin, clear oil. Made especially for magnetos, timers, bicycles and all fine working parts. Good to prevent rust of highly polished metal surfaces.

- Shipping weight, 4 oz.
- G6950—Can with handy spout..... **.20**

Funnels and Measures

Heavy, durable funnels for general use, also combination funnel and measure. Made of heavy tin and nicely finished.

Average shipping weight, 2 lbs.

- G7018—Plain round funnel, 1 quart..... **.16**
- G7019—Plain round funnel, 2 quarts..... **.30**
- G7026—Measure and Funnel, 1 quart..... **.30**
- G7027—Measure and Funnel, 2 quarts..... **.50**

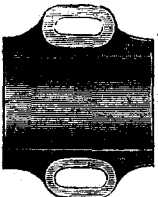
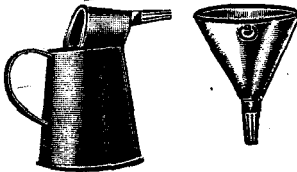

Adjustable Main Bearing Cap For Ford Crankshafts

By simply replacing the center bearing cap with this adjustable one, it is an easy matter to take up wear in the main bearings, keep the crankshaft always in place so that car is easy to start. Made of pure bronze, lined with nickel babbitt; has elongated holes giving adjustment from one thousandth to one fourth inch.

When worn on one end it can be reversed. Should last life of car. Satisfaction guaranteed. Shipping weight, 1 lb. Our Reduced Price K8044—Adjustable Bearing Cap, complete. **1.78**

End Thrust Bearing EASIER STARTING FOR FORDS

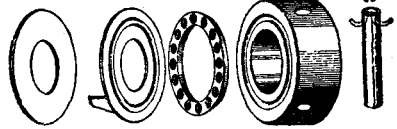

After a Ford car is driven a little while, the main bearings wear, and at the flywheel with magnets slip back away from the magneto coil assembly. This makes the magneto current weak, and the car is hard to start.

The end thrust bearing remedies this trouble by providing a special fan pulley that works on ball bearings against the front of the motor block, taking all end pressure from the main bearings and holding the crankshaft from slipping. Easily adjusted to allow for wear and keep the magnets at exactly the right distance from magneto coil.

Easily installed and will last indefinitely. Lets you start your Ford on the first turn. Makes big improvement in lights. Ship. wt., 1 lb.

- D6264—Complete for 1909-20 Fords, (small pulley) **2.20**
- D6265—Complete for 1920-24 Fords, (large pulley) **2.20**

De Luxe Cowl Ventilators

FOR ALL CARS

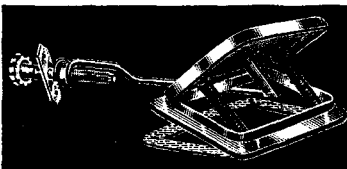

Made of solid aluminum, highly polished—not a metal stamping. Screws and hinges are concealed, add greatly to appearance. Strong springs hold

cover securely in place; will not vibrate or rattle. Quickly and easily adjusted without stooping, by simply turning knob on dash or instrument board. Cork gasket assures tight fit and keeps out rain or snow. Fits any car, aluminum being flexible enough to follow the lines of any cowl. Easy to install; full instructions furnished.

- E6533—Size 5x10 inches (ship. wt., 2 lbs.) **3.35**

Cowl Ventilators For All Cars

KEEP YOUR FEET COOL

Every car owner knows how the heat from the motor in summer almost "burns" the feet of anyone riding in the front seat, unless there is some way of letting in cool air. With one of our ventilators installed in the cowl of your car you will be able to let in all the cool air you want. Easily adjusted without leaving

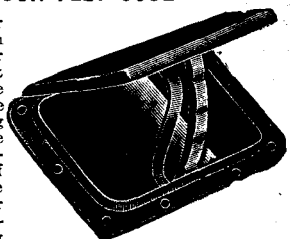

seat. Made of best-grade material and guaranteed to fit. Rubber gasket provided to prevent leakage between it and cowl. Finished in two coats enamel, baked on, and improves the appearance of the car. Furnished complete with instructions and all necessary bolts for installing. Ship. wt., 2 lbs. D6209—For any Ford Touring, Roadster or Coupe **1.28**

LONG-RUN OIL

BEST ALL THE WAY

The service and mileage you are able to get from your car depends to a great extent on the quality of lubricating oil used.

Our **Long-Run Oil** is of the highest quality.

It is carefully refined and prepared for us from highest grade cylinder stock by one of the largest oil refineries in the world, bearing a national reputation for the highest uniform quality of all their products. Perhaps you have been buying this very same grade under private trademark brand, paying about double the price we ask.

Because of our enormous buying power and the immense quantities of oil that we handle, together with our direct-from-refinery-to-car-owner system of distribution, we are able to furnish our customers Long-Run Oil for about half the price they are usually asked for the most common grades of oil at homes.

Poor oil may look just as good, but in using it you will soon find your motor knocking, overheating and weakening on long, hard pulls, caused by the cylinders, valves, pistons and plugs being covered with crusted refuse or carbon from the oil.

Oil takes a low freight rate and weighs about 8½ lbs. per gallon. It pays to order Long-Run Oil in quantities of 10 gallons or more in order to take advantage of the minimum freight rate.

Long Run Oil, in the larger sizes, is shipped in strong Non-Leakable Steel Drums with handy faucets. This overcomes the leakage and waste often experienced with wood barrels.

In ordering oil get light, medium, or heavy whichever you have been using or if you will give the make and year of your car we will send you the proper weight oil to use.

Another big advantage in getting your oil of us is quick service. Warehouses are located at Kansas City, Dallas, Houston, Minneapolis, St. Paul, Des Moines and Atlanta, and shipments are made direct from nearest point.

Send us all your orders for oil, and be assured of quick delivery as well as a big saving.

Long Run Oil for Ford Cars		Per gal.
X8679—50-gal. steel drum with faucet		.39
X8678—30-gal. steel drum with faucet		.44
X8677—10-gal. case (2 5-gal. cans)....		.58
X8676—5-gal. can.....		.60
X8675—1-gal. can.....		.70

Light Long Run Oil		Per gal.
X8702—50-gal. steel drum with faucet..		.39
X8701—30-gal. steel drum with faucet..		.44
X8700—10-gal. case (2 5-gal. cans) ..		.58
X8699—5-gal. can.....		.60
X8698—1-gal. can.....		.70

Medium Long Run Oil		Per gal.
X8709—50-gal. steel drum, with faucet ..		.45
X8708—30-gal. steel drum, with faucet ..		.50
X8707—10-gal. case (2 5-gal. cans)....		.62
X8706—5-gal. can.....		.65
X8705—1-gal. can.....		.72

Heavy Long Run Oil		Per gal.
X8716—50-gal. steel drum, with faucet ..		.52
X8715—30-gal. steel drum, with faucet ..		.56
X8714—10-gal. case (2 5-gal. cans).....		.65
X8713—5-gal. can.....		.69
X8712—1-gal. can.....		.76

Long-Run Oil has passed every test required for a perfect lubricant. The free carbon has been carefully removed by filtering through Fuller's earth, reducing carbon trouble to the minimum. The flash and fire tests prove that it is an oil which will retain its lubricating qualities even under high temperature.

Why continue to pay big prices and take the chances of using "just oil" when you can get **Long-Run Oil**, of guaranteed quality, for even less than you are asked for the cheapest grade of oil from local dealers? Oil takes a very low freight rate, so that transportation charges per gallon are very small.

Send for a can of **Long-Run Oil** and try it out. See for yourself the difference it will make in the running of your motor. Compare it with the oil you have been using or any oil on the market. You will then appreciate fully the exceptional value we are offering, and will want to take advantage of the greater savings offered by our prices in full barrel lots.

39¢ Gal. In 50 Gal. Steel Bbls.

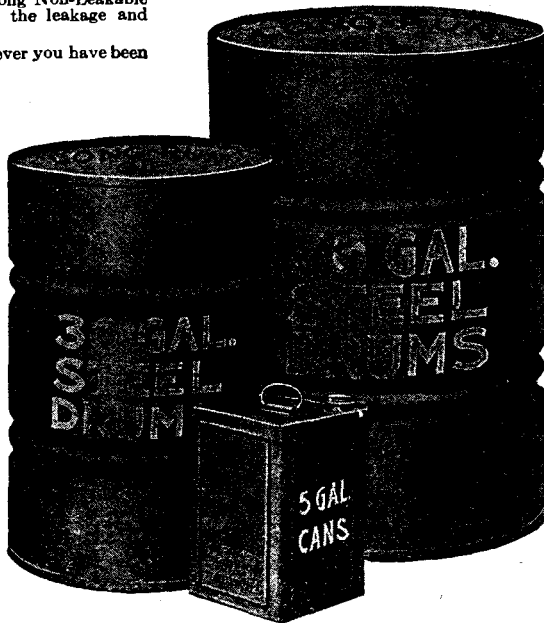

Long-Run Tractor Oil

High quality, carefully refined oil, with high fire test to stand up under the excessive heat of tractor engines. Furnished in extra heavy, which is best adapted to the needs of Fordson and other popular tractors. Shipping weight, 8½ lbs. per gallon.

X8753—50-gal. steel drums, per gallon.....	.59
X8754—30-gal. steel drums, per gallon.....	.63

LITTLE LIGHTNING COMBINATION GREASE AND OIL GUN

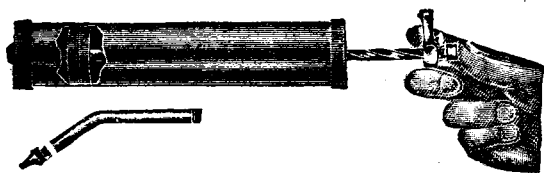

Regular and proper lubrication is just as necessary as oil and gasoline. It is an easy task if you have a good grease and oil gun. 90 per cent of differential damage can be traced to insufficient lubrication. This gun is exceptionally well made. Highly polished brass, double leather cup type plunger, reinforced with heavy steel washers, prevents any possibility of grease or oil passing to back of the gun. Positive pressure and strong suction insures quick and efficient work.

Has special plunger with two actions—first, that of the screw down type gun, producing a great pressure for greases; while simply pressing the button in the center of the handle converts it into a quick acting oil gun. The spout has a special oil nipple that will enter the smallest oil hole, and is quickly removed when used for grease. Cylinder is made of heavy seamless brass tubing. Size, 7 1/4" x 1 1/4". Capacity, 9 oz. Shipping weight, 1 1/2 lbs. **G7029—Our Reduced Price 1.18**

Rose Self-Loading Grease Gun



The only self-loading grease gun at a medium price. Fills by suction, and is so constructed that it will draw in reasonably hard grease easily. Made of heavy seamless steel, very serviceable, and convenient to use. Shipping weight, 2 lbs. **Our Reduced Price G7033—Size, 1 1/4" x 12 1/2" over all 1.08**

Ford Special Oil and Grease Gun

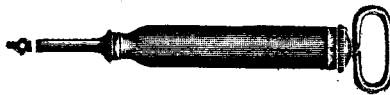

End of gun is made so as to fit in Ford differential. The cylinder is constructed from extra heavy steel and brass plated tube one and one-quarter inch diameter, nine inches long. Plunger is specially selected cork. These features make this gun practically indestructible. Extra nozzle for oil. Regular \$1.00 value. Shipping weight, 2 lbs. **G7036—Our Reduced Price37**

Genuine Replacement Parts for Alemite Lubricating Systems

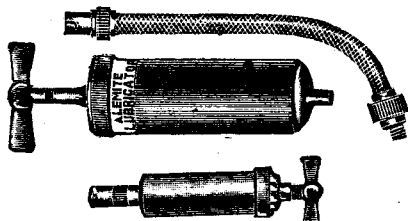

We offer a complete assortment of genuine Alemite replacement parts, also complete sets of fittings, compression gun, etc., to install a high pressure system on any car so that it can be serviced at any Alemite station. Also suitable for use on trucks, tractors, farm machinery, etc. Clean and easy to fill. Makes bearings last longer.

X9000—8" compressor, less hose (2 lbs.)	3.00
X9003—14" compression hose (1 lb.)	2.00
X9001—Junior compressor, with spiral valve coupling. No hose needed (1 lb.)	2.25

Straight Nipples

X9006—1/8" pipe thread13	
X9007—1/4" pipe thread21	
X9008—3/8" 32 machine thread21	

Elbow Nipples

X 9013—3/8" pipe thread26	
X9014—1/2" pipe thread36	
X9018—1" 32 machine thread66	

65-Degree Nipples

X9019—1/8" pipe thread30	
----------------------------------	-----	--

Dust Caps

X9016—Bayonet Dust Cap	5c	
----------------------------------	----	--

Straight Cap Nipples

X9021—3/8" 24 machine thread40	
X9022—1/2" 24 machine thread45	
X9023—3/4" 24 machine thread45	
X9024—1" 24 machine thread45	

Elbow Cap Nipples

X9025—1/2" 24 machine thread50 .60 .80 1.00	
X9026—3/4" 24 machine thread		
X9027—1" 24 machine thread		
X9028—1 1/4" 24 machine thread		

Pipe Bushings

X9035—1/2" x 1/2" pipe thread10	
X9036—3/4" x 3/4" pipe thread10	
X9037—1" x 1" 28 machine thread10	

Alemite System for Ford Cars

Quicker, Easier and More Efficient

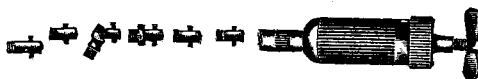

Most Ford owners neglect the vital, hard-wearing chassis bearings, because they are hard to get at, and because with the old-fashioned grease cups they frequently become clogged. Eighty per cent of all repairs on moving parts of a motor car come from faulty lubrication.

You can almost eliminate this expense by installing the Alemite High Pressure Lubricating System, now in use on more than 4,000,000 cars, and standard equipment on most high-priced cars. With this system, the old worn-out grease is forced out and fresh lubricant supplied to the whole bearing surface, as easily as putting oil in your motor. You can install it yourself in ten minutes, and it will pay for itself many times over the first year.

X9010—Alemite system for Fords as illustrated, consisting of compression gun and six nipples (2 rear axle, 1 drive shaft, 1 universal joint, 1 steering gear, and 1 fan) (ship. wt., 3 lbs.)	3.99
X9012—Alemite system for Ford, including compressor and nipples listed under X9010, and in addition wedge-in adaptors and nipples for equipping spindle body bolts, spindle arm bolts and all spring shackles (ship. wt., 5 lbs.)	6.25

Alemite Systems for Popular Cars

The advantages of Alemite high pressure lubricating systems are well-known. Easily and quickly installed by anyone. Make your car work better and last longer.

X9040—For Chevrolet 490 or Superior (same set now furnished as standard equipment with car), consisting of compression gun and 13 fittings to take care of all chassis bearings (ship. wt., 5 lbs.)	3.99
X9041—For Overland cars, 1920-24, consisting of compression gun and 22 fittings, to take care of all chassis bearings (ship. wt., 6 lbs.)	5.67

Prices on complete Alemite equipment for any car gladly furnished on request.

Alemite Lubricant

A pure solidified oil, recommended for use with Alemite lubricating system. 5-lb. size has the special patented top for quick and easy filling without soiling hands, or wasting lubricant.

X9038—Alemite Lubricant, 1 lb.40
X9039—Alemite Lubricant, 5 lbs.	1.50



IT PAYS TO HAVE A GOOD OIL GAUGE

DON'T TRY TO GET ALONG WITHOUT ONE.

Oil Gauges for Ford Cars

"As Necessary to the Car as Hands Are to the Clock."



To get best results from a Ford car, the oil supply should be just right. Too much is as bad as too little. That is why you need a reliable oil gauge. Testing oil by opening the drain cock is not only wasteful, but fails to tell you how much you really have.

We handle several grades of gauges, any of them worth the price we ask, but advise you to get one of the better grades, as it is cheapest in the long run.

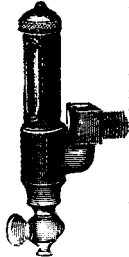

Gauge G6984, shown in the upper illustration, is a plain glass gauge, with a metal protection on two sides to prevent it from being broken by rocks or other objects thrown up by the wheels. The pipe screws in the lower pet-cock hole, and the pet-cock is screwed into the base of the gauge, so you can still drain your motor when desired.

Gauge G6985 is much more substantial. It is made of heavy cast brass, and the glass is so protected that it is almost impossible for anything to strike it. Pet-cock is furnished with this gauge, which is well worth the difference in price.

Shipping weight, either style, 8 oz.
G6984—Our Reduced Price 1 9
G6985—Our Reduced Price 4 2

"Jumbo" Oil Gauge

One of the heaviest and most substantial gauges made. Has heavy cast brass body, thoroughly protecting the glass. A notch indicates proper level for oil. Extra heavy glass tube protected by strong case. The pet-cock you remove from motor goes in bottom of gauge. A good reliable oil gauge is an absolute necessity. Too much oil develops carbon in the cylinders, fouling the spark plugs and pitting the valves, causing the spark plugs to miss fire and the valves to leak and eventually the motor needs a general overhauling. Will pay for itself many times over. Shipping weight, 8 oz.

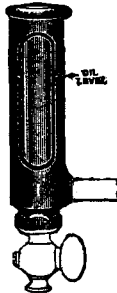

G6986—Each 48

Strong Metal Oil Gauge FOR FORD CARS

A heavy metal gauge that cannot be broken by flying stones thrown back by the wheels. Attaches with a small pipe to crank case at lower pet-cock opening. Oil level is shown by a white ball attached to the cork plunger by means of small wire. Nothing to get out of order. Easy to install. Prevents you from getting too much oil in the crank case and indicates when oil is low, thereby preventing burnt-out bearings. Ship. weight, 8 oz.

G6989—Our Reduced Price 65

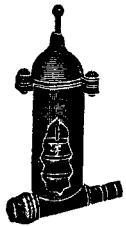

Pet-Cock Wrench

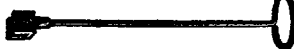

For use in opening pet cock to find oil level, without it being necessary to reach or crawl under car. Very convenient also to drain radiator, the drain-cock of which is in quite an inaccessible position. 20 inches long. Enamelled black.
H7183—Each (shipping weight, 8 oz.) 1 0

E-Z-Fil Gas Tank Cap for Fords

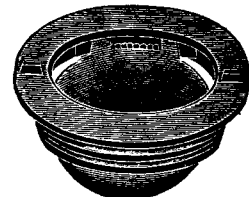

Replaces regular cap and eliminates necessity of removing cap every time gasoline is put into the tank. Push the gas hose nozzle down on the hinged lid and it opens—pull nozzle out, and the stout spring snaps lid back into place, snug and tight. Replaces regular Ford cap and lets you put gasoline in tank without removing cap. Substantially made of white metal with steel spring. Will save hours of time and no end of bother.
D6276—Each, (Ship. wt., 4 oz.) 38

Handy Oil Gauge

FOR FORD CARS

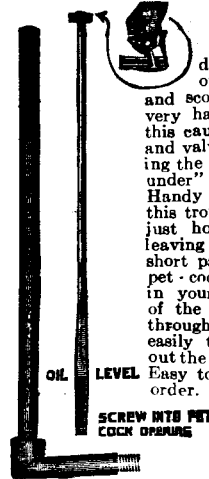

Nothing can cause quite so much damage to your car as running out of oil, burning out your bearings and scoring your cylinders. It is also very harmful to carry too much oil as this causes carbon, fouled spark plugs, and valve trouble. The old way of testing the oil level was to "get out and get under" and open the pet cocks. The Handy Oil Gauge does away with all this trouble and insures your knowing just how much oil you have without leaving your seat. Simply screw the short part of the gauge into the lower pet-cock opening, bore a small hole in your floor board, and the long part of the gauge will just barely protrude through this opening. Then you can easily tell your oil level by pulling out the center rod and reading the oil level. Easy to put on. Cannot get out of order. Nothing to break. Gives accurate reading. Put one on now and possibly save yourself the expense of a set of new bearings. Shipping weight, 1 1/2 lbs.

E6554—Complete with instructions 98

Handy Gasoline Filler Cap Gauge

This gauge can be relied upon to register the contents of your gasoline tank. Easily attached. Remove present filler cap on your gasoline tank, insert this gauge, and screw it down tight. Constructed of steel. Contains a float fitted to a spiral upright which turns indicator on dial, as the gasoline is raised or lowered in tank. Head containing dial and indicator fits any Ford tank. The extreme simplicity and strong construction means that it will always work perfectly and last as long as the car. Shipping weight, 1 1/2 lbs.

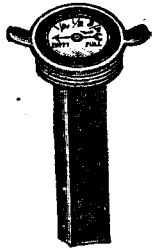

G6977—1909-1920 68
G6978—1921-23 Oval Tank 68

Universal Gas Gauge for Ford



An accurate filler-cap gauge for use on any model Ford. Has substantial float with three-sided stem on which are three sets of readings for either square, round or oval gas tanks. Lid of cap is pivoted, so that it swings to one side, letting tank be filled without removing gauge. When lid is closed, the gauge stem is entirely inside tank out of the way; to read gauge, simply swing lid back and the float rises to the surface of the gasoline, giving accurate reading on scale on stem.

G7044—Gauge complete (ship. wt., 1 1/2 lbs.) 78

Sure Feed Air Pressure Cap FOR FORD CARS

Because the Ford car uses the gravity feed system of fuel supply it often happens that you "run out of gas" when you really have a good supply in your tank. This occurs on hills and when the car is in a bad ditch, and is caused by the level of gas in the tank being lower than the carburetor. Our Sure Feed Cap prevents this. By means of a simple valve a regular tire pump may be attached to the cap and three strokes of the pump will give sufficient pressure for any occasion. Also very valuable for cleaning out a stopped-up flow line. A necessity on every Ford. Really gives your car a pressure feed system when you need it. Shipping weight, 6 oz.



G7022—Our Reduced Price 40

Extra Quality Radiator Caps

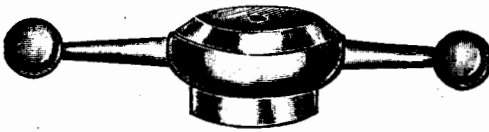

These are substantial, heavy caps, made of best quality material, heavily nickel-plated, so they will not tarnish. They are designed in size to conform to the size of the car on which they are used, and are made to withstand the severest heat without injury. Guaranteed to fit. Shipping weight, about 2 1/2 lbs.

- K8090—Fits all model Ford cars, also Gray..... **.68**
- K8091—Fits Allen 43 (female thread on cap), Cleveland, Dodge, Studebaker Light-6..... **.98**
- K8092—Fits Chalmers, Haynes, Lexington Lark and Model S, Mitchell, Oldsmobile 6, Model 37A, 43, 46 and 47, Stearns 1922-24, Stephens..... **.98**
- K8093—Fits Chevrolet 490 and Superior, also Star, Oldsmobile 30 and Essex 6..... **.85**
- K8094—Fits Allen 43 (male thread on cap), Chandler, except 1922, Cole, Elgin, Paige..... **.98**
- K8095—Fits Chevrolet (except 490 and Superior), Columbia, Dort, Essex 4, Gardner, Grant, Hudson (except Sport), Durant 6, Jackson..... **.98**
- K8096—Fits Maxwell 25, Overland 1923-24, Willys-Knight 1922-24..... **.98**
- K8097—Fits Buick, Durant 4, Nash, Oakland.... **.98**

Motometer Lock

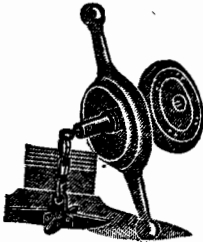

Prevents theft of your motometer, yet does not interfere with filling of the radiator.

When ordering specify make and model of car. Shipping weight, 1 lb.

- B5364—For Midget Ford and Junior Motometers..... **1.10**
- B5365—For Standard and Universal Motometers..... **1.10**

Radiator Caps for Ford Cars

Metal caps covered with black hard rubber composition top. Heat proof, prevent burning fingers, and are very attractive in appearance. (Ship wt., 8 oz.)



- B5352—Notched Pattern, ordinary grade..... **.14**
- B5355—Round Pattern, extra high quality..... **.28**

Ball Ornament For Radiator Cap



An attractive nickel-plated ball with stem for mounting on radiator cap as shown. Weight, 8 oz.

- B5517—Each (cap not included)..... **.35**

Motometer Ornaments



These popular ornaments fasten on top of motometer with the screws which hold the glass in place; easily installed by anyone. Made of solid metal, and durably finished in highly polished nickel plate. When ordering, be sure to give size of motometer. Ship. wt., 1 lb.

- A5160—Bathing girl..... **1.78**
- A5161—Shriner crescent..... **.95**
- A5162—Masonic Square and Compass..... **.95**
- A5163—Elks' Emblem..... **.95**

Radiator Ornaments



A beautiful radiator ornament adds distinction to any car, which accounts for their great popularity everywhere. Our ornaments are made of solid metal, which will withstand vibration and rough usage. Finished in beautiful gold plate that will not crack or peel off. Fasten on top of radiator cap; easy to install. Average ship. wt., 1 lb.

- A5233—Eagle, gold finish, 6 1/2 in. across wings... **1.68**
- A5234—Eagle, gold finish, height 2 in., width 3 in., each..... **.90**
- A5235—Masonic Square and Compass, gold finish, height 4 in., width 3 1/2 in., each..... **1.85**
- A5236—Shriner Tiger Claw, gold finish, enameled in regulation colors, height 4 in., width 2 1/2 in.... **1.85**
- A5225—I. O. O. F. emblem, gold finish, enameled in colors, height 4 in., width 3 1/2 in..... **1.85**

Divining Girl Ornament

An attractive radiator ornament, substantially made, handsomely nickel-plated. May be installed in radiator cap, or for use with motometer a little extension bar may be used to mount ornament about an inch in front of motometer. Av. ship. wt., 1 lb.



- A5193—Divining Girl Ornament, 2 1/2 in. high..... **.58**
- A5194—Divining Girl Ornament, 4 1/2 in. high..... **1.12**
- A5191—Extension Bar, to use with motometer..... **.12**

Radiator Cap and Eagle 43c
For Ford and Gray Cars

Radiator ornaments and nickel plated radiator caps have become very popular. Here is one made especially for the Ford car which we are offering at an unusually low price. Cap and eagle are beautifully nickel plated and rust-proof. Cap is 5 1/2 inches long.

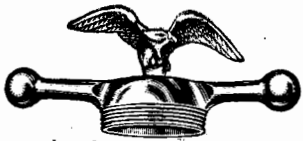

- B5501—Cap and Eagle complete. (wt. 1 1/2 lbs.)... **.43**
- B5502—Eagle only. (Ship wt., 8 oz.)..... **.19**
- B5503—Cap only—no hole drilled. (wt., 1 lb.)... **.27**

Le Luxe Radiator Cap for Fords

A beautiful nickel-plated radiator cap that covers up the unsightly radiator neck with a nickel-plated band. Has special adjusting feature which permits ball arms to always be parallel with the front of the radiator and at the same time keep the cap tight without any washers or bushings. A beautiful and useful accessory to your car. Length, 6 3/4 in.

- K8028—Each (ship. wt., 1 1/2 lbs.)..... **.95**

MOTO-WINGS FOR ALL CARS



Fastens between motometer and radiator cap. Made of brass, heavily nickel-plated, so that it will not rust. Measurements shown are from tip to tip of wings. Price shown does not include motometer or cap proper. Shipping weight, 1 lb. Our Reduced Price

- B5513—Moto Wings, 10-inch..... **.42**
- B5514—Moto Wings, 14-inch..... **.58**

GENUINE BOYCE MOTO-METERS

Protect Your Motor
\$2.65 and up



A safety thermometer signal that warns you when motor overheated, due to lack of proper lubrication, lack of water in radiator, etc. Prevents possible scoring of cylinders, burning out of bearings or even ruining of motor. A red danger signal always warns you in time. A motometer is a necessity; the cheapest protection you can have. Absolutely guaranteed.

BS363—Standard size, (3 3/4 in. x 5 1/2 in.)	7.45
BS362—Universal, (3 in. by 5 in.)	5.48
BS361—Junior size, (3 in. x 4 1/2 in.)	3.78
BS358—Midget Motometer (new style, glass both sides).	2.65
BS360—Special for Fords (with cap), (glass both sides) .	2.95

First four sizes shown do not include Radiator Cap.

MONOGRAM

Automatic Motometer Lock and Radiator Cap

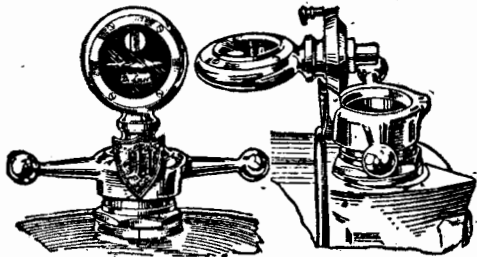

Screws on like an ordinary radiator cap, but cannot be removed except by taking off radiator and turning it upside down. Lid of cap operates on hinge, so that radiator can be filled without removing cap; a patented lever device holds the cap shut. Absolutely protects your motometer. Nothing to get out of order; no cables or chains to rust out, no keys to bother with. Strongly made of best-grade bronze, beautifully nickel-plated.

A handsome ornament for any car. Furnished with an emblem bearing your initial or any one of the following popular emblems: American Legion, Masonic, Knights Templars, Shrine, I. O. O. F. or Elks. In ordering be sure to specify emblem desired and give year, make and model of your car. **Price does not include motometer**—see special motometer prices at top of page. Easy to attach. Complete instructions furnished. Ship. wt. 4 lbs.

B5504—Complete cap and emblem for any car.	3.95
B5515—Junior Monogram cap for Ford, Chevrolet, Dodge, Gray, Maxwell, Star, Overland 1923-24, Essex 6, Oldsmobile Model 30, Chrysler, or Studebaker light 6—a smaller size cap with same locking arrangement as Monogram.	2.95

Be sure to give make, year and model of car when ordering.

"Security" Locking Radiator Cap For Popular Cars



A handsome, well-made radiator cap that will absolutely protect your motometer or any other radiator ornament you may put on. Has hole already bored in top, but fitted with neat plug, so it can be used with or without motometer. Lid tilts back for putting water in radiator. Special washer keeps motometer from being stolen by being removed from cap. Made of best-grade white brass, finely nickel-plated; will not rust or corrode, and will outlast your car. Easily installed but cannot be removed without tools. Full instructions furnished, also emblem bearing your initial. Ship. wt. 3 lbs. **Our Reduced Price**

D6221—For Ford or Gray	2.48
D6222—For Chevrolet 490 and Superior, Star, Essex 6 and Oldsmobile, Model 30.	2.48

Glo-Lite for Motometers Gives You 24-Hour Motometer Service

An attachment with bulb and special transparent dial, which fits on front of motometer and shows the reading at night as well as by day. Has five feet of armored cable which may be connected at the dash so that the Glo-Lite automatically switches on and off with your headlights. Has a green bulls-eye in front, also shows green light on right and red light on left side. Complete with 6-volt bulb, wire and full instructions. Ship. wt. 1 lb. **Price does not include motometer.**



H7401—For Midget or Ford Motometer	2.15
H7502—For Universal Motometer	2.95
H7403—For Standard or DeLux Motometer	2.95

"X" Radiator Liquid

Saves Repair Bills Repairs and makes leaky Radiators Leak-proof, Rust-proof, Scale-proof.

Contains no cement, powder, shellac, glue, meal, or other injurious material. It is positively not a cement to clog radiator pump or valves and ruin the cooling system. Prevents rust and scale. Is only process known that permanently repairs cracked water jackets without welding. When poured into radiator it automatically repairs all

leaks—tones up the entire cooling system of car—saves oil.

Manufacturer's Guarantee on Every Can.

Absolutely guaranteed to permanently repair any ordinary leaks in radiator, water jacket, pump and connections. G6921—Our Reduced Price, wt. 8 oz., (Ford size)..... **.62**
G6920—Larger size, wt. 1 lb..... **1.24**

Stop-Leak Radiator Cement

Instantly Stops All Ordinary Leaks

This is a new and improved radiator liquid cement that will instantly stop any ordinary leak. Does not contain any injurious ingredients. Will not clog radiator circulation system—in fact, it tones up the entire cooling system, prevents rust and scale, and saves oil.

Permanently repairs all ordinary leaks in radiator, water jacket, pump and connections.

Not affected by weather or climatic conditions. Positively guaranteed or your money back. Full directions on every can. Shipping weight, 1 lb.



G6929—Our Reduced Price, ½-pint can..... **.36**

Wasco Gum Shellac

Especially Adapted for Radiator Hose Connections

A good shellac should always be used around radiator hose connections to prevent leaks and add strength to the connections.

Our Wasco Gum Shellac is made of highest quality materials, made thick and heavy yet it dries slowly enough to allow sufficient time to thoroughly apply. Very adhesive and elastic, will not become brittle. Will withstand intense heat. Furnished in 2 and 4 oz. bottles with handy dauber cork for applying. Average shipping weight, 8 oz.

J7748—2 oz. bottle..... **.14**
J7747—4 oz. bottle..... **.32**
J7745—½-pint can..... **.32**

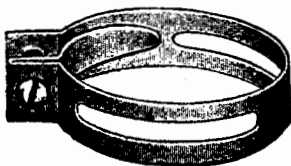
Plain Hose Clamps for Fords

Adjustable clamp made in two sizes to fit Ford radiator hose. Shipping wt., each, 4 oz.

B5398—Large, for top, each.... **5c**

B5399—Small, for bottom, each **5c**

Radiator Support or Truss

This truss is made of heavy metal and sets under the radiator. It is held by the bolt at each end and thoroughly supports the radiator, preventing breaks, strains, twists and leakage. J7796—Each, (shipping weight, 2 lbs.) **.26**

Ever-Tite**Solid Rubber Hose Connections FOR FORD CARS**

Withstand Vibration. Will Not Crack. Outlast Several Common Hose.

The same style of radiator hose as used on Liberty aviation motors. Actual tests proved that this strong, tough, solid rubber hose lasted three or four times longer than other hose. It is impervious to anti-freeze solutions and boiling water. It saves time, labor and money in replacing, requires no clamps, and is guaranteed absolutely for one year. Will fit all models Ford cars. Shipping weight, 5 oz.

B5385—Small, for bottom, each..... **.22**
B5386—Large, for top, each..... **.26**

**Radiator Hose For Ford Cars**

A standard quality radiator hose. Good live gray rubber.

Made in proper sizes for all models Ford cars. Shipping weight, each, 4 oz.

B5382—Small, for bottom, all model Ford cars..... **8c**

B5384—Large, for top, all model Ford cars..... **.11**

**Radiator Hose for All Cars**

A high-grade rubber and fabric hose for automobile radiator connections. Comes in 1, 2, or 3-foot lengths only. Sizes shown are inside diameter. Average shipping weight, about 1 lb. per foot.

No.	Inside Diam., Inches	Price, Per Ft.	No.	Inside Diam., Inches	Price, Per Ft.
B5520	1	.19	B5524	2	.30
B5521	1½	.23	B5525	2½	.34
B5522	1½	.25	B5526	2½	.39
B5523	1¾	.29			

Ideal Hose Clamp

The only perfect concentric hose clamp which will draw exactly the same all the way around hose without pinching at drawing side. It is impossible to prevent leaks unless you have good clamps. Don't try to get along with a makeshift; get the "Ideal." Shipping weight, 4 oz.

B5390—Large, for top hose of Ford car, each... **8c**
B5391—Small, for bottom hose of Ford car, each... **7c**

**Powdered Radiator Cement**

Many persons prefer a powdered radiator cement, especially for obstinate leaks, and we can recommend this kind as one of the best on the market. When applied according to directions, it dissolves instantly and will not clog or injure the radiator in any way. Full directions on every can. Satisfaction or your money refunded.



E6327—4-oz. can..... **.24**

Whiz Radiator Stop-Leak

This Liquid Stop-Leak is probably the most widely known of all the many radiator compounds. It repairs leaky radiators thoroughly, permanently and quickly while in use. You should carry a can in your car even if your radiator does not leak now because if it should spring a leak on the road you could repair it at once and possibly save yourself the expense of a new set of bearings. Can contains sufficient compound to repair a large size radiator of eight gallons capacity. One can may save you a \$25.00 repair bill. Order a can now and be prepared. Every can absolutely guaranteed or money refunded. Shipping weight, 12 oz



G6928—Our Reduced Price, per can..... **.68**

Improved Honeycomb Radiators for Ford \$9⁹⁵

30-Day Trial in Your Own Car

Our Improved Honeycomb Radiator offers many special advantages over the regular type Ford radiator. Chief among these is the "honey-comb" core, with almost four times the cooling capacity of the regular type, having 174 cubic inches of water channels, as compared with 44 cubic inches in the regular type, thus giving more cooling capacity and lessening the danger of freezing, because the flexible core will stand more expansion without injury.

Core Guaranteed 18 Months Against Breakage Caused by Freezing

These radiators are exceptionally well made. All parts coming in contact with the water are made of brass. Both upper and lower tanks are of one-piece brass construction, without seams, practically eliminating all possibility of leakage. The core is genuine brass, also the overflow pipe and the filler neck, so the cap couldn't possibly rust and stick fast.

The radiator has been scientifically constructed, so as to take all stress and strain off the core. The spring cradle supports under the entire bottom are soldered and bolted to the bottom tank, taking side strain off the radiator and permitting a resilient spring action. The spring side frames connecting upper and lower tanks are independent of the core and relieve it of all shock and strain. Even the hood rod holder has been reinforced.

Improves Appearance of Car

The graceful lines and attractive finish of these radiators make them an ornament to any car. The strong steel shell is finished with two heavy coats of black japan, or radiator can be furnished with fine nickel-plated shell as listed below. Comes complete with bar-arm cap, as illustrated.

Every radiator is carefully tested before leaving the factory. Comes securely packed in strong wood crate. Replaces regular Ford radiator—easy to install. Shipping weight, about 45 lbs. **Cannot be sent by mail.** In ordering be sure to give year of car.

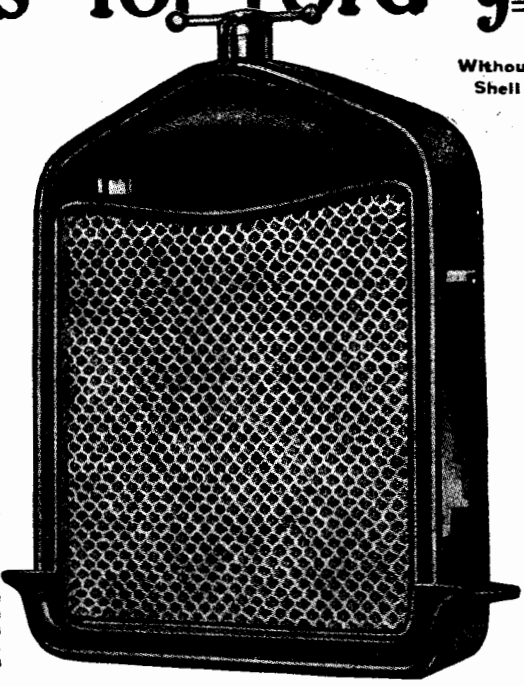

Without Shell

- | | |
|--|-------|
| X8554—For 1917-23 Ford, without shell..... | 10.95 |
| X8555—For 1917-23 Ford, with black enamel shell.... | 11.45 |
| X8557—For 1917-23 Ford, with nickel-plated shell.... | 11.45 |
| X8556—For 1909-16 Ford, with black enamel shell.... | 11.45 |
| X8558—For 1924 Ford, with black enamel shell.... | 11.45 |
| X8569—For 1924 Ford, without shell..... | 11.45 |

Superior Tubular Radiator

For Ford Cars

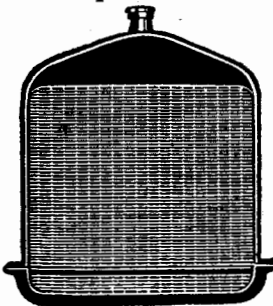

For those who prefer the regular tubular style of radiator, we offer this well-made high-grade radiator at a worthwhile saving. Made of the best material by one of the largest radiator manufacturers in the country. Carefully inspected and tested and fully guaranteed. Complete with substantial black enameled shell. Ship. wt., 50 lbs. **Can not be sent by mail.**

- | | |
|----------------------------------|-------|
| X8544—For 1917-23 Ford cars..... | 10.95 |
| X8545—For 1924 Ford cars..... | 11.95 |

Honeycomb Radiators for Maxwell, Chevrolet 490, and Dodge cars.



Has 2 1/2 inch thick, all brass core. All parts which come in contact with water are made of brass, including the one-piece top and bottom tanks which have no seams and are leak-proof. Core is finished in high grade gray enamel. Furnished without shell or with heavy steel shell finished in two coats of lustrous black enamel baked on. Comes well packed in substantial wooden box. Shipped direct from factory in Chicago. Avg. ship. wt. 50 lbs. **Not Mailable.**

- | | |
|---|-------|
| For Chevrolet 490 and Superior. | |
| X8920—1915-17 Thermo Syphon, without shell..... | 19.95 |
| X8921—1915-17 " with shell..... | 21.95 |
| X8922—1918-22 Pump Type, without shell..... | 18.95 |
| X8923—1918-22 " with shell..... | 20.95 |
| X8924—1923 Superior, without shell..... | 19.95 |
| For Dodge | |
| X8926—1915-16 without shell..... | 22.65 |
| X8927—1915-16 with shell..... | 24.65 |
| X8928—1917-22 without shell..... | 22.65 |
| X8929—1917-22 with shell..... | 24.65 |
| X8930—1923 without shell..... | 26.65 |
| X8931—1923 with shell..... | 28.65 |
| For Maxwell | |
| X8932—1916-19 without shell..... | 22.65 |
| X8933—1916-19 with shell..... | 24.65 |
| X8934—1920-21 without shell..... | 26.65 |
| X8935—1920-21 with shell..... | 28.65 |

Cleaner for Gas and Oil Line

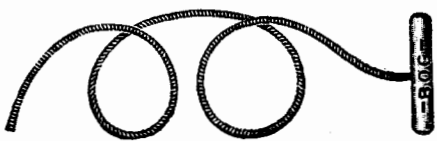

A flexible spiral coil of spring wire, 1/4 inch in diameter and 36 inches long, with handy handle; very useful for cleaning clogged gas and oil lines.
H7131—Each (ship. wt., 8 oz.)..... 39

Prices on Radiators for other cars on request.

YOUR FORD NEEDS A WATER-CIRCULATOR

The advantages of a water circulator are well-known. An overheated motor means loss of power, poor lubrication, with excessive wear and danger of burnt-out bearings, while an overcooled motor wastes gas, allows carbon to form and gasoline to get down into the crank case, where it causes trouble in the oiling system.

Our water circulator prevents these troubles. Will let you pull for miles in low without boiling the water. A fine thing in cold weather to warm up the engine quickly, also to keep water from freezing when facing the wind.

It is a positive "force-feed" system, which rushes the water through 7 to 10 times faster than the regular Ford system, yet does not interfere with the other system in any way. Driven by a 3-way heavy flat belt. Bracket of pump is bolted to motor—will not vibrate or wobble. Has three large bronze bearings, which will last indefinitely. Easily and quickly installed; comes complete with belt and full instructions.

This water circulator is made by a nationally known manufacturer of water pumps widely advertised under its own name, being retailed at around \$8.50, but because of the reduced price which our large volume enables us to make, we are not permitted to mention the advertised name. Sold under our regular guarantee of "satisfaction or your money back." Shipping weight, 12 lbs.

- | | |
|--|------|
| B5371—Complete for 1909-16 Ford Cars | 4.95 |
| B5372—Complete, for 1917-20 Ford Cars | 4.95 |
| B5374—Complete for 1920-24 Ford Cars with new style fan..... | 4.95 |
| B5373—Extra Belt for same. (State year of car) .. | .58 |



Leader Water Pump for Fords

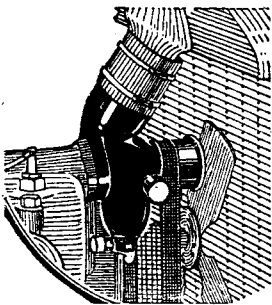

Pumps a radiator full of water once a minute at car speed of 20 miles an hour. Has a powerful, light-running suction propeller, which does not interfere in any way with the regular system in case the belt should break. Sediment plug at bottom permits easy cleaning. Has wide pulley with flange which keeps belt from jumping off. A grease cup on side of pump provides a means for keeping it properly lubricated at all times. Shaft runs in brass bushing and is

packed with 16 inches of asbestos. Can be installed by anyone in a few minutes. No holes to drill. This is a high-grade water pump, built for real service and should not be confused with the cheap imitations on the market at slightly lower prices. Increases power and saves gas and oil by keeping your motor at the proper temperature at all times. One long drive on a hot day will pay for it. Shipping weight, 5 lbs. B5376—Complete with belt for 1917-24 Fords... 2.95 B5351—Extra belt for Flood Pump..... .45

Double-Flanged Fan Pulley

FOR 1920-24 FORDS

Simply replaces the plain crank-shaft pulley that comes on the car, and keeps the fan belt from slipping off of either pulley. Lets you drive with assurance that fan is running. Lengthens life of fan belt. Especially fine for use with water circulator. Made of die-cast aluminum. Easily and quickly installed. (Shipping weight, 12 oz.)

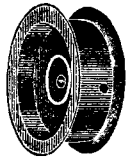

- | | |
|---|-----|
| B5367—Double-flanged pulley for 1920-24 Fords | .69 |
|---|-----|

Can be used on older models by using regular 1924 fan belt.

Fan Belt Guide for All Model Fords

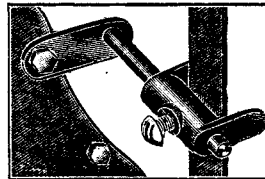

This Belt Holder will absolutely prevent the belt from slipping off the pulley of the Ford car. Every Ford owner should have one, and be always assured that his fan is working. Easily attached. Fastens to bolt on cylinder front cover. Will fit all model

- | | |
|-----------------------------------|-------------------|
| Ford cars. Shipping weight, 4 oz. | Our Reduced Price |
| B5241—Each, complete | .12 |

"Aero" Blow Hard Fan

FOR 1909-20 FORD CARS



A scientifically designed two-blade fan, made on the principle of the aeroplane propeller and much more effective than the old-style four-blade fan used on the Ford. The design of the blades causes them to catch and throw more air than a plain blade; also the air is thrown straight back, instead of being spread out toward the hood in every direction. Fits on in place of the regular Ford fan and will keep your motor cooler by throwing much more air than a regular fan. Fully guaranteed. Ship. wt., 3 lbs. B5378—For 1909-20 Fords only.... 1.15

"Jiffy" Crank Ratchet Pin for Ford

When a crank ratchet pin requires replacement it takes two men about one-half hour to put in a new one and rivet it in place. Sometimes you have to take off the radiator. Our "Jiffy" Crank Ratchet Pin slips into place and a steel spring clamps around the shaft and holds it. The pin slips in as easily as you would stick a pin through this paper.

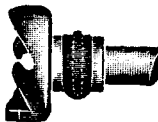

NEVER COMES OUT UNLESS YOU PULL IT OUT. NEVER WORKS LOOSE. B5300—Ratchet Pin, Each (ship. wt., 2 oz.)..... .10

Ever-Tight Crank Shaft Starting Pin for Ford Cars

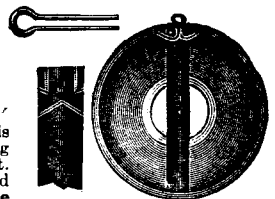

It takes but a few seconds to replace regular starting pin with the Ever-Tight. Just slip it into place and drive in the cotter from the end. Cotter spreads itself, ends wedging against inside of pulley, preventing all rattle and wear. Never comes out unless pulled out. Saves time and trouble. Complete ready for use. Shipping weight, 4 oz.

- | | |
|---|-----|
| B5308—For 1909—1920 Fords (2 1/4 in. long)..... | .16 |
| B5309—For 1921—1924 Fords (3 1/4 in. long)..... | .16 |

Rear Axle Gears

We are able to furnish Rear Axle Gears and Pinions for almost any car at prices that will save you 25 to 50 per cent. Prices upon request.

Roller Bearings for Front Wheels

For Fords and Chevrolet 490. These are high grade steel roller bearings, made the proper size to fit Ford front wheels and spindles. They are tapered pattern, insuring perfect adjustment. Much more durable than ball bearings, in fact will last almost indefinitely. Complete set bearings for two front wheels. Shipping weight, set, 4 lbs.

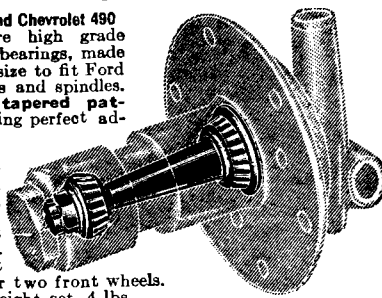

J7837—Roller Bearings, Per Set..... **3.95**

Babbiting Jig

REBABBIT YOUR FORD CONNECTING RODS

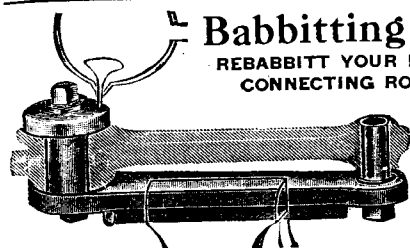

Enables you to renew the babbit bearings in Ford connecting rods at small cost. Full directions are included with each one. It is accurately made so that when babbit is poured in it will have correct centers. Can be used by Ford owners as well as repair men. H7492—Babbiting Jig, each (Ship. wt. 3 1/2 lbs.)... **.85**
H7493—1 lb. Babbit (enough for 4 rods)..... **.67**
H7494—3-inch Babbiting Ladle. (wt. 1 lb.)..... **.45**

Spindle Bolts and Bushings

for Ford Cars



When spindle bolts and bushings are worn they should be replaced at once, as a worn, weak bolt may give way when running fast and wreck the car. Our bolts are extra quality steel and bushings are special bronze. Set consists of 2-2710 spindle body bolts, 2-2718 spindle arm bolts, 4 steel grease cups for same, 4-2713 spindle body bushings, 2-2714 spindle arm bushings, 2-2711 spindle body bolt nuts and 2-2719 spindle arm bolt nuts.

B5476—Full Set Bolts and Bushings (wt. 2 lbs.) **1.18**
H7373—Reamer for fitting 2713-2714 Bushings (weight 1 lb.)..... **.95**

Note—These parts can be put in without the reamer, but it is an easier job when reamer is used.

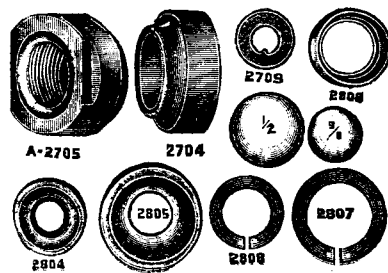

A-2705 2704
2705 2708
2805 2807
2804 2808

You should always have these bearings in your tool box, especially when starting on a trip. Being prepared costs but very little and may save you hours of delay and big expense if your bearings should give way out on the road. Shipping weight, 3 lbs. B5477—Full Assortment for Both Front Wheels. **Our Price... 1.78**

2-2704 Stationary Cones **.30**
2-2705-6 Adj. Cones, 1 R., 1 L. **.30**
2-2707-8 Spindle Nuts, 1 R., 1 L. **.10**
2-2709 Spindle Washers..... **.04**
2-2804 Outer Races **.20**
2-2805 Inner Races **.30**
2-2806 Outer Ball Retainers **.04**
2-2807 Inner Ball Retainers **.06**
2-2808 Dust Rings **.10**
2-2809 Front Hub Felt Washers ... **.10**
24-2810 Large Balls **.96**
22-2811 Small Balls **.66**
Reg. Factory List would total **3.16**

Kil-Nock Bearing Adjusters for Connecting Rods

For Popular Cars

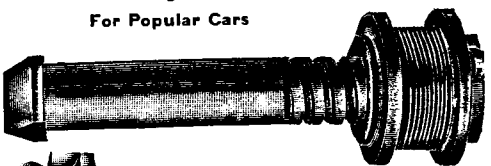

Positively stop connecting rod knocks and keep the bearings tight. The small tension spring keeps the spool nut turned up to the right position and makes the bearing cap fit snugly at all times thereby eliminating knocks. The force of the explosion is not on the spring, but on the spool nut, which has more strength than the regular bolt and nut on account of the peculiar deep thread. As easy put in as regular connecting rod bolts and will last as long as the car. After a real saving as they save the cost of several jobs of adjusting your bearings at less than the cost of one job. Come complete with instructions ready to put on. Shipping wt., 1 lb. **Our Reduced Price**
J7893—Complete set of 8 for Ford, Chevrolet 490, Gray and 1920-24 Overland **2.55**
J7883—Complete Set for Dodge cars or Fordson tractor..... **4.35**

Motor-Tecto-Fone



Enables anyone to locate readily all knocks or trouble in the motor or other moving parts. Simply place the bell receiver to the ear and the end of the rod on the outside of the motor walls of place where trouble is suspected. The slightest knocks and clicks will be instantly audible. Test your motor frequently as a safeguard against loose rods, piston pins or other moving parts. It takes only a minute's time, and may save you a big repair bill. Three pieces, quickly assembled, make

it easy to carry. Shipping weight, 2 lbs. C5567—Motor-Tecto-Fone, complete..... **.95**

Drive Shaft Tube Support

A Sure Trouble Saver

On many Ford cars the drive shaft tube breaks at the flange where it is attached to the differential. This support clamps on over end of tube and around D. S. Roller Bearing housing, making it impossible for such a break to occur even under the severest strain of the worst roads. Even after a tube is cracked or broken you can use this clamp and save the expense of a new tube and work of installing. Shipping weight, 4 lbs.

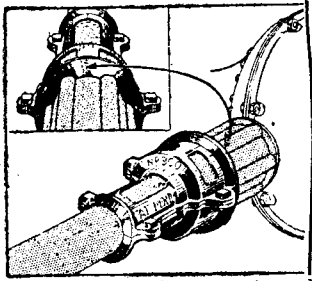

J7807—Each, **Our Reduced Price... 1.95**

MOSPICO SAFETY SPINDLES FOR FORD CARS



The Mospico Safety Spindle is not straight like the ordinary spindle. It has an offset of $\frac{1}{4}$ of an inch, which sets the center of the wheel $\frac{1}{4}$ inch back of the center line of the axle. This causes the wheels to be pulled instead of being pushed. It is an age-old principle applied a new way. It acts like the casters under a piece of furniture.

This spindle makes the front wheel always travel in a straight line, regardless of the obstructions you meet. You could even disconnect the tie rod on the left wheel and it will still travel parallel to the right wheel just the same as though everything was connected up properly.

Mospico Safety Spindles stop the jerking of the steering wheel and make it easy to drive the Ford. No more strain on the arms; no more fatigue from "hanging on" to the steering wheel. They add to your pleasure by relieving you of the fear of what will happen when you hit a stone or rut, or turn out to pass another car.

Mospico Safety Spindles may save the lives of yourself and family. Don't wait until it is too late. Easy to install. Full instructions with every set. Shipping weight per pair, 7 lbs.
J7824—Our Reduced Price, per pair..... 3.95

Sprague Worm Steering

FOR FORD CARS

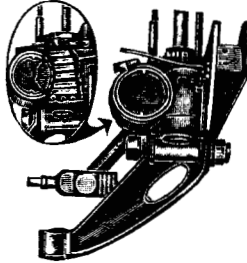

The Sprague Worm Steering Gear is the same type used on most large cars. Gives you absolute control of the steering. It gives more power from the steering wheel and steers easily out of ruts. It prevents the front wheels from "wobbling" on rough roads or turning aside when you strike a rock. They can not possibly cramp suddenly and throw the car into the ditch. The only way you can change direction of

travel is by turning the steering wheel.

Prevents accidents and adds greatly to the pleasure of driving. It eliminates vibration, jerking and strain on the driver's arms and shoulders. Lets you drive without constantly gripping the steering wheel as the gear carries the car straight ahead without danger of swerving or bucking. Makes your car safe and easy for the women to drive.

It is easy to install the Sprague Worm Gear. It bolts to the frame of the car. No holes to drill, no cutting of rods, no special tools. Full instructions furnished. Fits all makes and models of Ford cars.

The worm and gear are made of a very high-grade steel. It is built to outlast your Ford. Requires no special attention, an occasional oiling being all that is necessary. **Your money back in 30 days if not satisfactory.** Or **Reduced Price** Regular price, \$20.00. **A5182—Complete Outfit (ship. wt., 16 lbs.)... 11.75**

Front Axle Brace

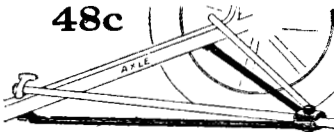

Fastens to radius rod back at ball socket connection and extends forward under each radius rod, to brace the front axle. It strengthens the radius rod, stops all

vibration of front axle and gives steadiness to steering wheels. Keeps the front axle in perfect line at all times and eliminates danger of a wreck by crumpling of radius rod when front wheels hit a hole or deep sand. Average shipping weight, 10 lbs.

J7792—Heavy Angle Steel, 1909-1919 Fords..... .64
J7794—Heavy Angle Steel for 1920-24 car with radius rod at bottom of axle (not shown)..... .88

APCO Steering Column Brace



Supports the steering column and prevents the base of the column loosening at the dash. It also prevents excessive vibration and rattle of the steering wheel and makes it solid. An absolute necessity on every Ford car. Fits all models.

Finished in black enamel.
B5243—For any model Ford (ship. wt., 1 lb.)... .49

Straight-Ahead Steering Guides

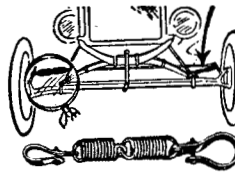

Hold your car in a straight course, eliminating much of the strain of driving. Will automatically straighten the car out after turning a corner. Prevent front wheels from buckling in mud or sand. Made of two strong coil springs which fasten to steering arms and radius rod with special clamps. Easy to put on; will last indefinitely. Ship. wt., 1 lb.

A5184—Set of two, with full instructions..... .98

Slip-on Anti-Shimmie

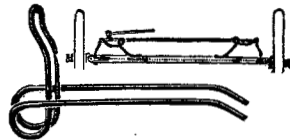

Consists of two springs made of heavy tempered steel wire, finished in black enamel. One end of each spring slips into the clevis at end of spindle connecting rod, the other end being

spring into place in the channel at rear of front axle, thus keeping the steering gear under tension even when the wheels are cramped for turning around.

Well-made and durable. Nothing to rattle or get out of order. Satisfaction guaranteed. Ship. wt., 2 lbs.
B5272—Set of two, complete..... .98

Clamp-on Steering Column Brace



Takes the vibration out of the Ford steering column. Makes driving more comfortable, more pleasant and safer. Easily attached by anyone with a small wrench and screwdriver, as it simply clamps on the instrument board. No holes to drill. So designed that it fits equally well on instrument boards with or without wood backing. Neat and practical; for any model Ford with instrument board. Ship. wt., 1 lb.

B5295—Black enamel finish .72
B5296—Nickel-plated finish..... .95

Sturdy Steering Column Brace

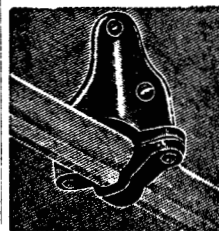

It is very dangerous to drive a Ford car without some kind of a steering column brace, as the column vibrates and makes it hard to hold the wheel. This brace is very desirable, as it makes the column rigid and prevents it from vibrating and rattling. A strong, well-made brace, finished in black enamel. Shipping weight, 1 lb.

B5294—Brace complete for any late model Ford car with metal instrument board..... .44

GENUINE STEWART SPEEDOMETER

With new colored dial and lubrication chart.

FOR FORD AND STAR CARS.

No car is complete without a good speedometer. This model Stewart Speedometer is designed especially for use on the instrument board now provided on the new model Ford cars, also on all closed model Star cars. There are five different colors on the dials. Each color as it appears indicates that sufficient mileage has been covered to require lubrication of certain parts of the car. Furnished complete with lubrication chart, attached to speedometer, which folds under out of sight when not in use, but turns down below dial for ready reference.

Built on the magnetic principle exclusive to Stewart Speedometers only. Three-inch dial face, large plain figures, 75-mile capacity rotating speed dial, 100,000-mile season odometer and 100-mile trip register which can be set any tenth of any mile. Tungsten steel magnet, jeweled pivots. Flange matches starter switch plate. Finished in black enamel. This is the latest Stewart Speedometer with the improved swivel joint. Complete with fittings and instructions. Shipping weight, about 12 lbs.

Our Reduced Price

A5080—New style, complete with lubrication chart. **11.85**

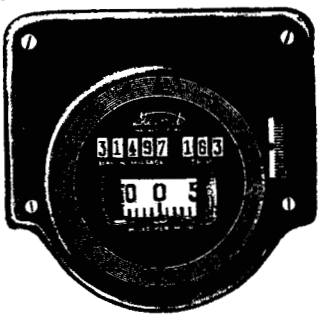

Parts for Stewart Speedometer

At a Worth-While Saving in Price

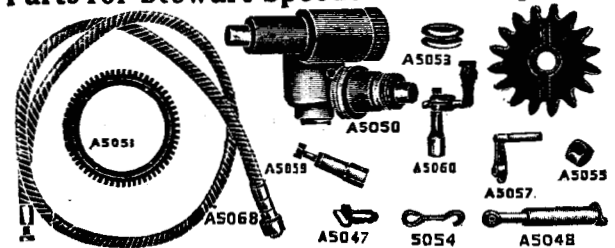

- No. A5069—Flexible Shaft Complete, 66" long. (Ship. wt. 4 lbs.) **2.15**
- No. A5068—Flexible Shaft Complete, 60" long. (Ship. wt. 4 lbs.) **2.15**
- No. A5054—Links for Chain, each **1c**
- No. A5047—Upper Clutch of Chain **.10**
- No. A5048—Lower Clutch **.26**
- A5049—Leather Shaft Holder **.15**
- A5050—Swivel Joint, Right Hand. (Ship. wt. 2 lbs.) **1.48**
- A5052—Fibre Pinion, No. 1. **.10**
- A5051—Road Wheel Gear. (2 lbs.) **1.60**
- A5053—Rubber Fender Washer **.14**
- A5055—Clamp Swivel Block. **.35**
- A5057—Clamp Part. **.55**
- A5059—Steering Arm Extension. **.38**
- A5060—Clamp Assembly on arm **1.85**

Favorite Auto Clock



A dependable "clock-watch" in a two-piece case of solid nickel. Classy bright finish, very attractive. The case is lined in such a way that it absorbs shocks and prevents vibration from affecting the movement. Case is made so that cover fastens securely over the watch. Movement is fully guaranteed for one year. Case takes any standard number 16 size watch. Very accessible and easy to attach to any cowl board. Ship. wt. 1 lb.). **2.65**

Genuine Phinney-Walker Clocks FULLY GUARANTEED

An auto clock is a great convenience and time-saver, besides adding to the attractiveness of the car. Phinney-Walker clocks are of the highest quality, specially constructed to withstand the vibration of auto use. Are installed as factory equipment on many high priced cars. Beautiful black lacquered finish; 2½ inch dial. Ship. wt. 3 lbs.



- A5039—"Erie" 8-day movement, lever-wind. **6.35**
- A5035—"Detroit", 8-day movement, rim-wind **9.85**

Minute-Meter Auto Clock

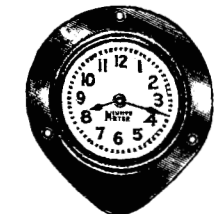

An accurately made, handsomely finished "clock-watch," which fits flush on the dash—any dash, wood or metal, of any thickness. Can be regulated without dismantling from the dash, and is provided with an effective vibration absorber, assuring you of correct timekeeping. One-day movement; fully guaranteed. Nickel-plated case. Easily installed—full instructions furnished. Sh. wt., 1 lb.

- A5045—Minute-Meter, as illustrated. **2.35**
- A5046—Luxlite Minute-Meter with luminous dial for showing time in dark (not illustrated) **3.35**

Flower Vase For All Closed Cars

A beautiful high quality ornamental glass flower vase, which will make a great improvement in the appearance of your Sedan or Coupe. Bracket is of brass, heavily nickel-plated and is designed so that the glass part can be easily removed from the holder and placed back into position without the least inconvenience. Has screw attachment that prevents vase from rattling or working loose, while top is so designed that it is non-splashable. Height, about 7 inches. Shipping weight, 2½ lbs.

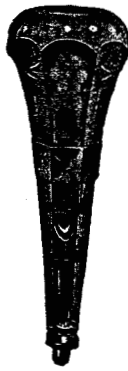

- Our Reduced Price
- B5492—Vase as illustrated **1.15**
- B5467—Cut glass vase (not shown), 9 inches high, extra quality **1.68**

Electric Cigar Lighter

No more hunting for matches, or having them blown out before you get a light. Lighter consists of holder, which fastens flush on dash, with several feet of cord on automatic reel, which keeps lighter out of the way when not in use. Tip is removable, so any light bulb can be inserted and outfit used as a trouble light. Attractively nickel-plated. A great convenience for the man who smokes. Full instructions for attaching.

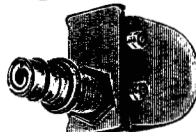

- C5707—For 6-volt battery (ship. wt., 1 lb.) **2.98**
- C5730—Genuine Cuno Cigar Lighter, (not shown) with extension cord and automatic reel **3.65**

Ash Receiver

A beautiful combination ash receiver, match box holder and cigar rest. Made of solid brass throughout, heavily nickel plated. Receiver is detachable for cleaning purposes and is perfectly sanitary. Two hooks are attached to the back of bracket permitting receiver to be instantly placed in any position or it may be attached with screws to dash or side of car. Ship. wt., 1 lb.

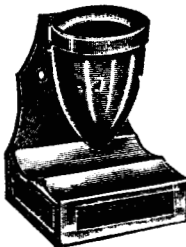

- D6229—Each **.98**

Stop the Rattles

After a car has been run for a while, it begins to rattle in a great many places. Anti-Rattling Devices have been produced to silence the various parts by taking up the wear. Put on a few of the Anti-Rattlers shown on these pages, and notice the big difference they will make.

Steering Arm Anti-Rattler



For Ford Cars

A very cleverly made little spring device that fits over the ball joint of the steering gear ball-arm and clamps around steering gear connecting rod. Effectually stops all rattling at this joint and lessens the wear. Ship. wt., 8 oz. **B5246—Steering Arm Anti-rattler, each..... .20**

Throttle Rod Springs

Specially prepared steel springs which are easily snapped in place and prevent the rattle of spark and throttle rods on steering post. Shipping weight, 4 oz.

B5247—Throttle Rod Springs, pair..... .27

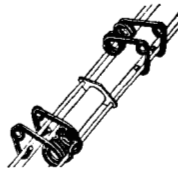

Brake Rod Support Anti-Rattler

A specially designed steel spring which slips through the brake rod support to prevent the pull rod from rattling against the support—a rattle that no other device has ever stopped effectively. Ship. wt., pair, 8 oz. **B5248—Brake Rod Support Anti-rattler, pair... .27**

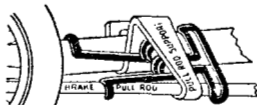

Tie Rod Silencer and Guide

20c PAIR

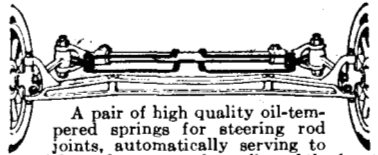

A pair of high quality oil-tempered springs for steering rod joints, automatically serving to hold the car straight and prevent rebounding of the front wheels when you strike a bump or hole in the road. Stops all rattling and vibration of the steering rods and saves having to renew the spindle arm bushings and bolts. Ship. wt., 8 oz. **B5252—Tie Rod Silencers, pair..... .20**

Brake Rod Springs



Fit in the brake rod clevis and clamp around the rod, stopping the annoying rattle of loose clevis ends. Come four in a set, one for each end of each rod. Ship. wt., 8 oz. **B5249—Brake Rod Springs, set of 4..... .20**

Complete Set Anti-Rattlers for Fords. STOPS ELEVEN DIFFERENT RATTLES

A complete set of above anti-rattlers for tie rods, brake rods, steering arm, throttle rods and brake supports. Stops rattles and vibration; saves bushing replacements. All used cars need them—installed on new cars, the rattle never starts. Ship. wt., 2 lbs. **B5254—Set of 11 Anti-rattlers..... 1.05**

Ideal Door Anti-Rattler

For Ford Closed Cars

Every owner knows how soon the doors of a Ford sedan or coupe wear down the little rubber bumpers and begin to rattle and thump. Here is a device that overcomes this trouble by having two high-grade coil springs behind the rubber, so that as the rubber wears the springs push it forward so it will still hold the door tight. Comes complete, metal frame, rubber and springs as shown, of proper size to fit snugly in place of regular metal socket. Easily installed; all you need is a screw-driver. Will last indefinitely. Ship. wt., 4 oz.

C5903—Ideal Door Anti-rattler, each..... .29

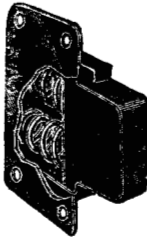

Door Anti-Rattlers

For Auto Doors

Can be put on by anyone in a short time with a screw driver and two screws. Will stop the rattle and last as long as the car. Will fit practically any car, on most cars near the latch, but on some cars next to the hinge. Shipping weight about 2 oz.

Our Reduced Price
B5304—Each..... .10
Per pair..... .18

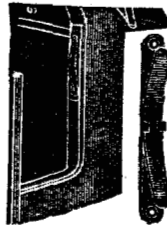

Fender Anti-Rattlers

Will fit any make of car.

These Anti-Rattlers are strong pressed steel brackets made to fit in the corners where the fenders rattle against the metal shield, and are attached firmly with

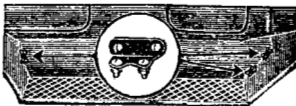

bolts furnished. You need two for each front fender and one for each rear. Shipping weight, set of 6, 8 oz. **B5276—Fender Anti-rattler, each, with 4 bolts..... 5c**

Door Silencers for Closed Cars



Best quality rubber bumpers, which replace the plain rubber bumpers with which the car is equipped, fitting into the same retainers. The vacuum cup grips the door tightly, preventing motion. The air-cushion holes check the door when closing, and hold it firmly when closed, eliminating

all rattling. The high-quality, non-blooming black rubber insures long life. Easily installed. Ship. wt., 2 oz. **B5320—For Dodge, prior to 1924, each..... .10**
B5321—For Buick, Cadillac, Chandler, Chevrolet 1922-24, Cleveland, Ford prior to 1922, Stephens, Studebaker..... .10
B5322—For Ford closed cars, 1922-24..... .10

Anti-Rattling Ball Sockets for Ford Radius Rods

Replaces the solid cap that holds the front radius rod to the front of the engine and absolutely eliminates all rattling, takes up all wear and holds the joint firmly. It requires only a few minutes' time to remove the old cap and replace with our device, which will never wear out, having an adjustment which can be tightened if spring ever becomes loose.

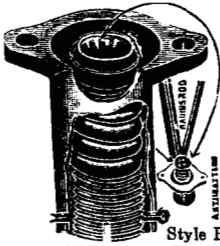

Our Reduced Price
B5259—Each (wt., 8 oz.) .25

Style B

Handy Handles FOR FORD DOORS

Handy Handles are made in a solid casting, handsomely black enameled; attach to the regular Ford door handles. They project a little way above the top of the door and permit the door being opened without the usual fumbling to find the door catch. With a light pressure on the Handy Handle, the door opens easily. They are attached by simply driving over present door handles. Anyone can put them on in a few minutes. Should be on every Ford car. Ship. wt., per set of 3, 1 lb.

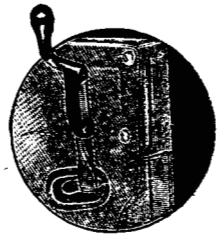

Our Reduced Price
B5311—Each10 Set of three26

Steering Rod Anti-Rattler

Made similar to the one shown above, but smaller, and replaces solid cap on ends of steering gear connecting rod. Eliminates lost motion, absorbs shocks and vibration from wheels; makes steering easier and is a necessity on every Ford.

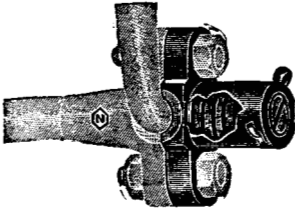

B5256—Pair (weight, 8 oz.) Our Reduced Price. . .25

Window Silencers

Stop Rattling of Windows in All Closed Cars

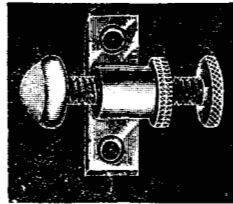

Made of brass, nickel plated, with rubber cap on end that sets against glass window. A knurled head screw makes it easy to tighten. The bracket screws to side of window. When screw is set prevents rattling, vibration and broken windows in closed model cars. An absolute necessity for every closed car. Ship wt., 6 oz.

B5266—Our Reduced Price, each13

Hood Silencers FOR POPULAR CARS

Ends the annoyance of rattling hoods. Made of rubber, with vacuum cup at one end which holds them against the car hood, and slot at other end into which the hood fastener slips. Easily installed; just slip into place. No possible chance for rattle. Ship. wt., set of 4, 12 oz.

- B5317—Small, for cars with hood clamp about 1/4" from hood, set of 478
- B5318—Large, for cars with hood clamp about 1" from hood, set of 498
- B5319—Hood Silencers for Ford—rubber cushions which slip under edge of hood (not illustrated), set of 442

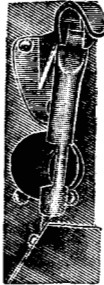

Spindle Joint Silencers

This is one of the most important anti-rattlers. Strong springs take up the wear and rattle, prevent wobbling of front wheels due to worn bolts or bushings. Quickly slipped into place with pliers. Wt. 4 oz.

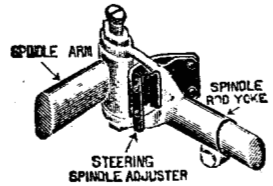

B5280—Pair25

Fender Fixer FOR FORDS AND OTHER LIGHT CARS

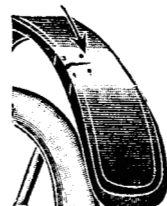

Just the thing for repairing broken or weak fenders on Fords or other

light cars. Made of 20 gauge steel stamped to fit. Can be put on by anyone in a few minutes and makes the fender stronger than ever. If your fenders are beginning to break better put one on now and save buying a new fender later.

B5315—Each. (Shipping weight, 4 oz.)12

Hood Clips For Ford Cars

A new style, handy, quick-working hood clip for Ford cars. Replaces present clips as shown in illustration. Easily installed by anyone in a few minutes time. Has good spring, encased in substantial frame; well finished in black enamel. Furnished only in sets of four. Shipping weight, 1 lb.



Our Reduced Price
K8029—Set of 4, complete88

Web Lacing for Hood



Heavy strips of web lacing to go under ends of hood to prevent it from rubbing against radiator and dash hood support. For all cars. Saves wear on these parts and stops the noise of a rattling hood. Shipping weight, 4 oz.
B5270—3/8 inches wide, per yard7c 6 yards . . .38
B5271—5/8 inches wide, per yard9c 6 yds . . .48

Ball Shim for Universal Joint ON FORD CARS

Takes up the excess play at the ball joint, stopping oil leakage and rattle. Also stops rear axle chattering when starting and stopping. Can be installed in ten minutes and does the work that would otherwise require \$10.00 worth of new parts and hours for installation. Made of best material and will last indefinitely. Satisfaction guaranteed.

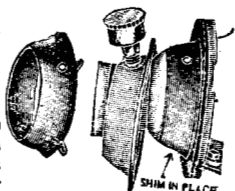

Our Reduced Price
B5571—Complete with instructions, (Ship. wt., 12 oz.) .72

Anchor Running Board Brace

For All Model Ford Cars

Every one knows how Ford running boards sag down when a passenger steps into or out of the car. This puts a strain on the mudguards, which soon become loose and rattle, while broken truss rods and supports are frequent occurrences.

All this trouble can be avoided by installing this brace. Made of strong angle iron, with rods that hook over the frame of the car for support and are quickly adjusted to the proper length. Wood blocks on end furnish ample support to running board.

This brace is strong enough to hold up the running boards all alone if necessary. Makes them perfectly solid, so they move only as the frame and body move. Lets you carry battery or tool boxes, or entire camping and touring outfits on your running board without strain on fenders or truss rods. Easily and quickly installed; comes complete with fittings. Ship. wt., 12 lbs.

W8381—Brace, complete,.....Our Reduced Price **1.12**

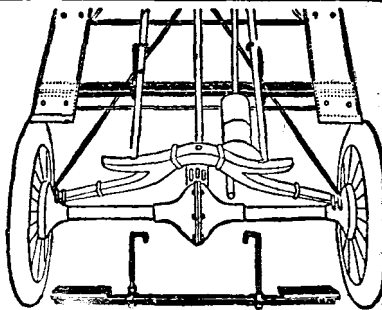

**Handy Repair Arm
FOR FORD CRANK CASES**

When a Ford crank case arm breaks, repairs are difficult, expensive and time-consuming. The engine must be taken out of the chassis and torn apart so a new arm can be riveted on. All this trouble is eliminated with the use of this handy repair arm. All that is needed is to loosen four bolts, slip the repair arm in place and bolt up. Strong and substantial. A wonderful time and money saver. For all model Ford cars.

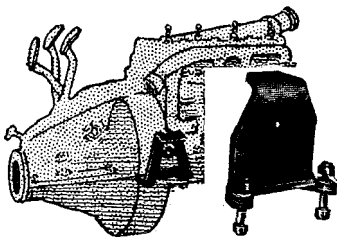

J7810—Each (Ship. wt., 3 lbs.)..... **.45**

**Silent Timing Gears
FOR POPULAR CARS**

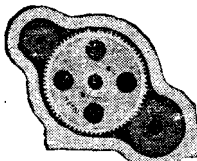

When metal timing gears become slightly worn, they grind and rattle, making a peculiarly disagreeable noise. You can avoid this by installing our Silent Timing Gear, which is made of a specially prepared gear material, which cushions the motor shocks, yet is hard enough and strong enough to outwear gears of cast iron. This material is used as standard equipment by most high-priced cars and has stood the test of years of service. Oil and water-proof; will not swell, shrink or warp. Easily installed.

- H7561**—For Ford cars (replaces 3047B large timing gear) (Ship. wt. 1 lb.)..... **5.95**
- H7562**—For Chevrolet 490 and Superior (replaces crank shaft and generator gears) (Wt. 2 lbs.)... **4.80**
- H7563**—For Overland 1920-24 (replaces crank shaft, camshaft and generator gears) (5 lbs.)... **6.40**
- H7564**—For Dodge 1915-24 (replaces camshaft gear) (Ship. wt. 2 lbs.)..... **7.20**

Prices on Silent Timing Gears for other cars gladly furnished on request.

**HIGO
Chatter Cure for Ford Cars**



A simple and effective preparation used in the cylinder oil to relieve the glazed condition of Ford transmission bands and do away with the nerve-racking chattering and grabbing. Will save the cost of relining your bands until they are entirely worn out.

Higo is a perfect lubricant that will not gum, corrode or congeal, not affected by heat or cold. No need to change your oil to obtain results—just add a pint to any good lubricating oil and the chatter will be eliminated at once.

Makes driving a pleasure; enables you to stop your car quickly, avoiding accidents. Satisfaction guaranteed or money refunded.

G6893—Quart can (Ship. wt., 3 lbs.)..... **.45**

Crank Case Support

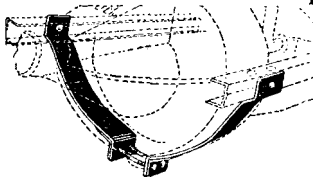

Why pay a repair bill of \$20. or more when a crank case support will hold broken crank case arms firmly together as long as you Ford lasts. It will also help support the motor and prevents the crank case from breaking or tearing loose.

Hard strains often loosen the rivets holding the arm to the crank case, allowing oil to escape around the loose rivets. Our support will prevent this. Made of strong metal. Shipping wt. 6 lb.

J7787—Complete with Bolts and Nuts..... **.81**

**Dunn Motor Support and Thrust Member
FOR FORD CARS**

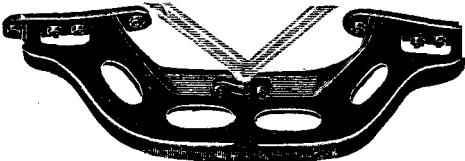

Will take up the road shocks and give your car thousands of miles of added life and save many dollars in repair bills. Made of highest grade malleable iron and the end are fastened to the frame by a U-bolt, which holds it rigid.

At the point where the radius rod engages, a half ball is machined, which fits snugly into the socket already in the crankcase. Beneath this half ball a new socket is made to receive the ball on the end of the radius rod. The same stud, ball cap, springs and nuts are used as before. No hole to drill. All new bolts needed are supplied. Any one can attach it in a short time. Other supports hold the motor "up," but the "Dunn" holds it steady and firm.

W8342—Each (Ship. wt., 12 lbs.)..... **3.91**



Anti-Slip Brake Wafers

Prevent rear hub brakes from slipping and squeaking when the lining has become oil-soaked, water-soaked or worn. They make the auto brake silent and sure. They also prevent slipping of cone clutches, fan magnets, belts, or any friction gripping surfaces. Non-injurious to lining or belt.

1 9220—Box of 25 Brake Wafers.... **.47**

Brake Juice for Rear Axle Brakes

Do your bands squeak and slip when you apply the brakes? You have probably had this trouble. It is caused by the asbestos becoming glazed so that it will not have the proper friction against the steel drum. Our Brake Juice is a specially prepared liquid for applying between the brake lining and the drum, giving a new surface to the lining and providing greater friction. Will also stop slipping of fan and magneto belts. Just squirt it on, it does the work. Shipping weight, 12 oz.



G7077—½-pint can with spout..... **.38**

EXTERNAL SERVICE BRAKES

FOR FORD CARS—STOP THE JERKING

Do Away With 75% of Transmission and Rear Axle Trouble

Rear axle brakes are universally recognized as the most practical and efficient. Our brakes are adapted for Ford cars and work on the same principle as those on the most expensive cars. They deliver the braking power direct to the rear wheel drums, thus taking all strain off the axle shafts, drive shaft, gears, keys and bearings. Will save accidents as well as repair bills.

Give a firm steady pressure that reduces the possibility of skidding and does away with all the rattle and jar and chatter caused by braking on the transmission. The saving in wear and tear on car and tires will soon pay for the brakes.

These brakes attach to the regular foot pedal. A flexible steel cable equalizes the pull on the two wheels, while a turnbuckle makes it easy to take up all wear. Linings easily replaced when worn out. Easily and quickly installed by anyone with a wrench. No machine work of any kind necessary. Full instructions with every set.

These are the highest quality rear axle brakes on the market. They are asbestos lined and made of the best material throughout, with extra heavy, substantial bands. They should not be confused with the lighter-weight brake sets offered by some at slightly lower prices. Shipping weight, set, 15 lbs.

W8377—Complete Set, with full instructions for installing. **6.95**
 W8378—Complete Set for Ford One-Ton Truck. **15.95**

\$ 6.95 Set

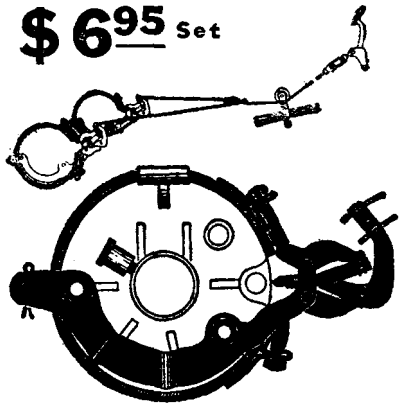

Cast Iron Brake Shoes For Ford Cars

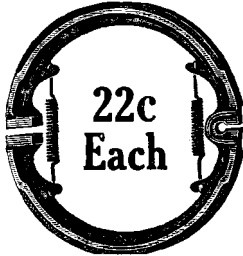

Made of good quality gray cast iron, exactly the same size and shape of the shoes which come in the Ford. This style wears much longer and holds better. These shoes are good value for the money but greater value is received by paying a little more and getting the pressed steel shoe shown on this page.

Shipping wt., each, 2 lbs.
 D6120—Each. **.22**
 Per pair. **.42**

“Ever-Safe” Steel Brake Shoe

The last word in brake shoe construction. Positively eliminates every disadvantage of the old-fashioned cast iron brake shoe. Combines strength and durability of steel. **Cannot** break slip or warp, and lining can be replaced in few minutes when worn. Will last 10,000 to 25,000 miles on the original set of lining. Fits all Fords (1909 to 1923).

The patented supporting steel guide absolutely prevents buckling and really makes this shoe worth a good many pairs of the ordinary steel shoes. Shipping weight, per pair, 4 lbs.

D6108—“Ever-Safe” Steel Shoes, per pair. **1.78**



Rear Brake Cam and Bushings

Many times rear brake shoes are blamed for not holding when the fault is really in worn cams and cam bushings, allowing the cams

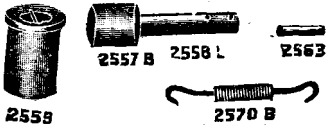

to wobble around and “ride” up on the end of brake shoe, pressing the shoe down out of position. If your cams are loose, get a new pair with bushings. Ship. wt., set, 1 lb.

B5475—Set, one right and one left cam, No. 2557-8; two cam bushings, No. 2559; four No. 2563 pins. **.34**
 P2570B—Brake Shoe Spring, each. **.2c**

Brake Shoe Adjusters for Fords

When the Ford emergency brake shoes are half worn out they must be thrown away, as the brake shoe cams do not open the shoes wide enough to engage the drums. By driving these adjusters over the cams you can extend the life of the shoes at least fifty per cent.

Will last indefinitely.
 D6112—Pair (Wt., 2 oz.) . . . **.14**

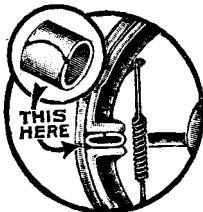

Pressed Steel Brake Shoe



Practically Unbreakable. Made of cold rolled steel pressed into shape and lined with high quality asbestos brake lining. This lining is interwoven with fine copper wire to make it strong and wear-resisting. Holds much better than a plain iron shoe, lasts much longer and will not break into pieces like the cast iron. Can be lined again and again with our special lining. Ship. wt., pair, 4 lbs.

D6116—Per pair. **1.29**

“Adjusto” Brake Shoes For Ford Cars

A high-grade, two-piece brake shoe with a patented adjusting feature, making it easy to take up wear, so that brakes always take hold evenly. Simply take a wrench, loosen lock-nut, turn cam slightly, then tighten lock-nut—not necessary to remove wheel or crawl under car.

Fit in place exactly like regular shoes. Two-piece construction eliminates strain and breakage. Adjusting cam is case-hardened to resist wear. Let you wear shoes entirely out making them the cheapest shoes you can buy in the long run, besides giving you assurance of control over your car.

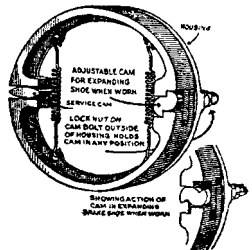

Transmission Band Oiler For Ford Cars

An effective device for preventing grabbing and chattering of Ford transmission bands. When the oil is thrown up by the fly wheel it is caught by the oiler and flows down over all three bands. This gives the bands a constant bath of oil which keeps them soft and pliable. Easy to install, no holes to drill. Will last as long as the car.

D6015—Each (Ship. wt., 8 oz.) **.29**

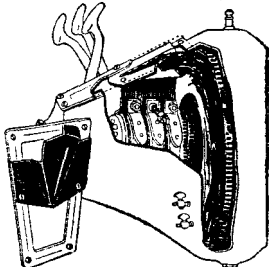

D6114—Per pair (Ship. wt., 4 lbs.) **1.78**

Everbest Asbestos Brake Lining



A strictly high quality brake lining. Contains 90% fine staple long fiber asbestos yarn closely interwoven with high quality brass wire. Will not char or burn from friction heat, does not soften or become hard. Heat-proof, water-proof and oil-proof. Made full standard size and thickness. Made by one of the oldest and most reliable factories in the country with many years' experience and a reputation for making quality products. Do not take chances with cheap inferior brake lining. Make your car safe. The best is the cheapest in the end. Average shipping weight, 6 oz. per foot. Be sure to state length, width and thickness in ordering. Our prices offer a real worth-while saving.

Number	Width Inches	Thickness Inch	Reg. Price per ft.	Our Price per ft.
D6239	1	3/8	.40	.10
D6240	1 1/4	5-32	.55	.16
D6241	1 1/4	3-16	.60	.17
D6242	1 1/4	3-16	.70	.21
D6243	1 1/4	3-16	.80	.23
D6244	2	3-16	.90	.26
D6245	2 1/4	3-16	1.00	.32
D6246	2 1/2	3-16	1.10	.34
D6250	1 1/4	3/8	.80	.25
D6247	2	3/8	1.20	.36
D6248	2 1/4	3/8	1.30	.39
D6249	2 1/2	3/8	1.50	.44

Never-Burn Asbestos Brake Lining

Highest Grade, Hydraulic Pressed

The great advantages of the hydraulic pressed brake lining are now coming to be generally known. Our "Never-burn" is constructed of pure asbestos, interwoven with best quality brass wire. Then it is compressed and cured at 2,000 lbs. pressure for one hour at intense heat. This hydraulic pressure makes the density of the lining fixed and unvarying; while, being cured under heat, it is not burned out or affected by heat in service. Is also unaffected by oil, water, gasoline or dirt.

Costs a little more than ordinary lining, but gives better service, makes your car safer, and lasts longer, making it far cheaper in the long run. Shipping weight, about 8 oz. per foot. Be sure to state length, width and thickness desired.

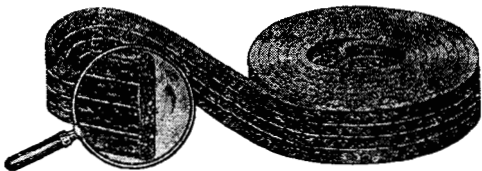

Number	Width Inch	Thickness	Price per ft.	Number	Width Inch	Thickness	Price per ft.	Number	Width Inch	Thickness	Price per ft.
D6121	1	3/8	.18	D6123	1 1/4	3/8	.27	D6128	2 1/4	3/8	.49
D6122	1 1/4	3/8	.25	D6124	1 1/4	1/2	.32	D6119	1 1/4	1/2	.36
D6115	1 1/4	1/2	.29	D6125	1 1/4	1/2	.33	D6129	2	1/2	.58
D6117	1 1/2	1/2	.34	6126	2	1/2	.36	D6130	2 1/4	1/2	.68
D6118	2	1/2	.38	D6127	2 1/4	1/2	.45	D6131	2 1/2	1/2	.68



Tubular Brass Rivets for Brake Lining

Very best quality tubular rivets, the kind most generally used for lining brakes on large cars. Sold in packages of 100. Shipping weight, per package, about 8 oz.

Number	Length About Inch	Diameter About Inch	Price per Hundred
D6260	3/8	9-64	.28
D6261	1/2	9-64	.32
D6262	5/8	9-64	.34



Split Brass Rivets for Brake Lining

Shipping weight 6 oz. per box

J7647	5-16" long (Ford size), box of 100	.14
J7646	3/4" long (Ford size), box of 100	.19
J7645	1/2" long, box of 100	.20
J7649	3/4" long, box of 100	.24

Transmission Band Tool

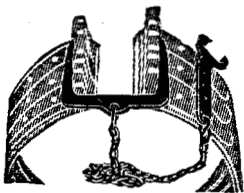

The holding of the transmission bands together while replacing the top of the transmission case is an annoying problem. The tool shown is designed to eliminate this difficulty.

The clamp shown in the cut holds the bands in perfect alignment and can be put on and removed instantly. The wrench which

is attached to the clamp with a chain fits adjustment nut and the chain prevents losing either of the tools in the transmission case, which often causes trouble and delay.

H7132	—Tool Complete	.35
H7530	—Clamp only (without wrench)	.19

Automatic Transmission Band Adjusters FOR FORD CARS

A simple but effective device which automatically adjusts the Ford reverse and brake bands. Consists of a ratchet and pawl assembly which clamps over the regular adjusting nut. As the linings wear, the foot pedal goes down a little further, allowing the pawl to drop into the next notch of the ratchet and tighten the nut just enough for proper adjustment.

Prevents the grabbing and chattering of loose bands. Prevents the wear on linings caused by adjusting bands too tight by hand. Keeps them always just right—and car always under control. The action is positive and automatic; requires no attention—cannot get out of order. Works in oil; nothing to wear out. Guaranteed for life of car. Comes with full instructions, and is as easily installed as adjusting your bands—all you need is a wrench. Install a set at once—it may save you a serious accident.

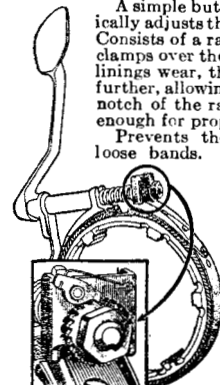

D6094	—Set of 2, complete (ship. wt., 1 lb.)	1.79
-------	--	------

NEVER-BURN BRAKE LINING



One of the most important things about your car is your brake lining. You must have good brakes or you are in constant danger. You should use only the best quality lining and always keep your brakes properly adjusted, then you are safe from accidents caused by defective brakes.

Our Never-Burn Transmission Lining for Ford cars has been proved by many severe tests to be absolutely dependable, one of the longest wearing and nearest "never-burn" of any on the market. It will not glaze or crumble like cheaper lining.

It is a very firm, solid lining, which oil and the heat of the motor will not affect, and will wear almost indefinitely. It will not "grab" or "chatter" like cheaper grades of lining, but wears perfectly smooth, always giving you a

firm grip and perfect control of the car, enabling you to slow down or stop suddenly without danger of the brake grabbing and sliding your wheels. If you have had trouble with ordinary lining burning out quickly or "grabbing," get a set of **Genuine Chatterless "Never-Burn."** You will get better satisfaction and more wear for your money than from any lining you have ever used. It pays to get only the **very best**, as the work of putting in a set of lining costs more than the lining. The "Never-Burn" comes three pieces to a set, 23" long, 1 1/4" wide and 5-32" thick, with rivets included. Shipping weight, 1 lb.

D6100—"Never-Burn" Transmission Linings for Ford, complete set with rivets..... **1.35**

Genuine Scandinavia Brake Linings FOR FORD CARS

This well-known high grade transmission lining will not grab and chatter like cheap grades, but wears evenly and always gives you a firm grip and perfect control of the car. This allows you to slow down or stop quickly without the danger of your brakes grabbing and sliding your wheels.

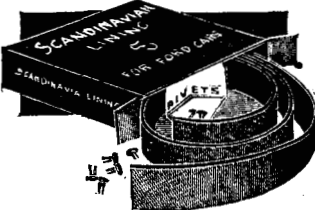

Scandinavia Lining is an imported lining made especially for Ford transmission bands. Made of a special treated long staple weave. Especially treated to resist oil, heat and grit. This well known brand of brake lining needs no introduction. Complete set of three linings, with rivets ready to attach. Shipping wt., 1 lb.

D6095—Our Reduced Price, per set..... **1.58**

Economy Felt-Bak Brake Linings



A very efficient, self-lubricating lining, made of high quality webbing with a felt strip sewed on the back, similar to our D6105, but without the cork insert feature.

The felt acts as a cushion and oil pad, the oil being forced to the surface of the transmission drum through two rows of oil holes in the webbing, whenever pedal is pressed down. This keeps the drum from getting hot, so that bands do not chatter, grab or char, but remain soft and pliable. Makes bands grip tighter and last longer.

Complete set of 3 linings with rivets. Ship. wt., 1 lb.
D6102—Our Reduced Price, set..... **1.28**

Genuine Advance Feltbak Brake Linings FOR FORD CARS



FULL SET
2.18

This is high quality lining, similar to our "Never-Burn," with round pieces of cork about 3/8 inch in diameter inserted to take the wear. Cork is almost wear-proof, and is widely used on clutches in large cars. We have handled this lining for years and found it stands up under every test.

The new "Feltbak" style has a felt strip sewed on the back, which serves as a reservoir for oil, so that when you step on the pedal, oil is forced through the holes in the center of the lining. Will outwear two or three sets of any other kind. Regular price, \$2.75. Shipping weight per set, 1 lb.

D6105—Set of 3 pieces, with rivets..... **2.18**

Brake and Transmission Band Linings FOR FORD CARS

For those who prefer lower-priced linings we offer two grades.

D6091 is the plain untreated lining, like the regular equipment on Ford cars. **D6090**, same grade, specially treated to withstand heat and wear. Each set complete, three pieces, with rivets, ready to use. Ship. wt., 1 lb.

D6090—Complete Set—Treated..... **.55**

D6091—Complete Set—Untreated..... **.45**



COUNTERBALANCED CRANK SHAFT FOR FORDS



Reduces wear on your motor and all other parts of your car. Smoother. Will improve the running of your motor 100%. Shipping wt., 20 lbs. **W8385—Our Reduced Price 13.95**

A complete Counterbalanced Crank Shaft for Ford motors, made on the same principle as some of the highest priced cars. The counterbalances are not welded to or bolted on the crank shaft but are a part of it and for this reason they cannot break and fly off or loosen. Made of highest grade alloy steel and guaranteed to fit. It develops maximum power without increasing fuel consumption. Smooths out cylinder explosions and eliminates vibration. Lessens repairs. Lengthens life of your car. Makes riding smoother. Shipping wt., 20 lbs. **W8385—Our Reduced Price 13.95**

Springs for Ford Cars

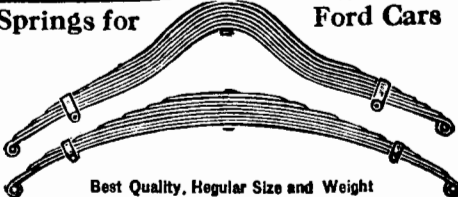

Best Quality, Regular Size and Weight

These are regular standard quality, standard weight, springs made of high-grade spring steel that is especially prepared to meet the requirements, stand the loads, jerks and strains to which an automobile spring is subjected.

- W8330—Front Spring (ship. wt., 18 lbs.) 1.48**
- W8331—Rear Spring (ship. wt., 47 lbs.) 4.78**

Spring Shackle Assembly

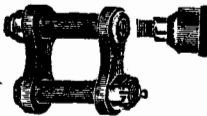

The regular spring hangers of the Ford usually become worn and shaky very soon from lack of lubrication. Our shackle assemblies are accurately made and threaded for use with compression grease cups, which insure positive lubrication, easier riding and much longer wear. Can be used with ordinary grease cups or with Alemite lubricating system (see page 70). **Two assemblies are required for each spring.** Shipping weight, 1 lb. each.

- J7848—For Ford front spring (without cups) each. 4.33**
- J7849—For Ford rear spring (without cups), each. 4.33**
- G7015— $\frac{3}{4}$ " grease cup (takes two for each assembly), each, 6c 8 for. 4.42**

Knowlson Spring Leaf Spreader

A practical and valuable device for spreading the spring leaves. Makes spring lubrication easy which prevents rusting and squeaking; also eliminates breakages and prolongs the life of the spring and Best repair clamp made. With on a broken spring. Made of drop forging, nickel plated and highly polished. Absolutely guaranteed.



assures comfortable riding. its use you can ride safely on a broken spring. Made of drop forging, nickel plated and highly polished. Absolutely guaranteed.

- H7560—Each (ship. wt., 1 lb.) 1.55**

Penetrating Spring Oil



Simply use a brush to flow oil along the edge of each leaf. It penetrates, cuts the rust, grease, and dirt, and works its way between the leaves, leaving a good coat of the lubricant. Also good for body squeaks and for loosening nuts, bolts, screws, locks, etc., that are stuck with rust. Easy-working springs will make your car and tires last much longer. Get a can of spring lubricant and see what a difference it makes in the way your car rides.

- G7079—4 oz. bottle with swab.36**
- G7084—Pint can (ship. wt., 1 1/2 lb)39**

Spring-Eez

An extremely popular lubricant for automobile springs, as well as for use on bicycles, locks, typewriters, sewing machines, etc. Eliminates rust, gummed oil and dried greases, and deposits a pure lubricant to the most inaccessible moving parts. A simple external application will penetrate and lubricate all the leaves of an automobile spring, stopping squeaks and preventing rust. Instantly cuts rust on nuts, cap-screws, etc.



- G6869—3-oz. handy can with spout.30**
- G6870— $\frac{1}{2}$ -pint can (ship. wt., 12 oz.)60**
- G6871—Pint can (ship. wt., 1 1/2 lbs.) 1.00**

Dunn Counterbalances

Increase power and speed—reduce vibration

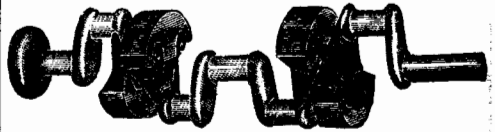

The advantages gained by using counterbalances have been thoroughly proven. The Hudson motor, and others, immediately came into prominence on account of their extreme power, speed and flexibility, after adopting counterbalances. On a Ford they make a wonderful improvement. You can hardly believe it is the same car, it runs so smooth, quiet and without vibration, even on hard pulls or at high speed. The principle is correct, as any expert mechanic will tell you.

Dunn counterbalances are made especially for Fords, Dodge, Chevrolet and Overland cars. They can be put on by anyone without taking down the motor, by simply removing the crank case lower cover. They attach rigidly and permanently. No danger of coming loose. Complete instructions with each set. We will refund your money if not satisfied with them after ten days' trial. Shipping weight, 18 lbs. **Our Reduced Price**

- J7770—Set complete for Ford cars 4.20**
- J7771—Set for Chevrolet '490' and Superior 4.95**
- J7772—Set for Dodge 5.95**
- J7773—Set for Overland Four 4.95**

Extra Quality Connecting Rods FOR FORD CARS AND TRUCKS

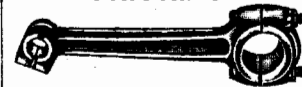

Carefully made forgings with finest S.A.E. specification babbitt bearings, nicely and accurately finished

Fits perfectly. If your Ford is "knocking" don't take it to a shop and pay a big repair bill. With our special wrenches you can put in new parts yourself. Have a set of connecting rods on hand for emergency. Shipping weight each 3 1/2 lbs. Reg. list price \$1.20 **Our Reduced Price K8017—Connecting Rod, each (Ford No. 3024)98**

"Heavy Duty" Springs For Ford Cars



Made Extra Heavy For Hard Service

These springs are made much heavier, stronger and more substantial than the regular standard grade. They have eight leaves in the front and ten in the rear. Especially suitable for Ford cars being used in severe, strenuous work over hilly, rocky or bumpy roads or for Fords having commercial bodies and carrying heavy loads. The "Heavy-Duty" Springs will stand far more hard usage and overloading than the regular weight. They are made from the very finest spring material procurable and are very flexible considering their extreme strength. If you are having trouble with springs breaking, get a pair of "Heavy-Duty".

- W8388—"Heavy-Duty" Front, 8 leaf (ship. wt., 20 lbs.) (no special clips needed). 2.28**
- W8389—"Heavy-Duty" Rear, 10 leaf, with special long clips (ship. wt., 62 lbs.) 6.95**
- J7733—Extra Clip for 10-leaf rear spring39**

Roller Thrust Bearings

FOR FORD DIFFERENTIAL

Also Fit Chevrolet 490

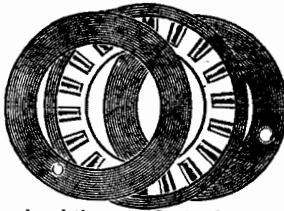

Stop rear axle trouble by preventing wear, stopping friction and keeping gears in perfect mesh.

This taper roller thrust bearing has one hundred times more real bearing surface than a ball thrust and protects the entire differential from gear

and end thrusts. It simply replaces the old thrust plates Nos. 2528 and 2529. The plain washers soon wear thin, allowing looseness and back-lash in the differential. There is a heavy thrust on these washers when pulling hard or turning curves, and as soon as the washers wear down a little, the teeth of the gears do not mesh perfectly, but run on the points, which causes them to wear rapidly and break before they give full service.

Order a set of roller thrust bearings today and be through with differential trouble. Full instructions furnished for installing. Shipping weight 2 lbs.

J7777—Roller Thrust Bearings, set of two. **3.28**

Extra Quality Ball Thrust

STOPS REAR AXLE TROUBLE

An exact replacement for worn washers at gear side of Ford and Chevrolet 490 differentials. Keeps gears in perfect mesh.



Made of finest materials, carefully heat-treated and ground. Has 18 micro-chrome 1/4-inch balls and is guaranteed to "stand up" under every strain. Keeps gears in mesh, prevents wear and axle breaks. Instructions for installing furnished.

Our Reduced Price

J7780—Ball Thrust, each. **1.10**

Gears and Pinions For Maxwell 25



High quality hardened gears and pinions for Maxwell cars. Made from best grade drop forged steel. Accurately machined and guaranteed to fit. Our prices offer a worth while saving.

- J7908—Rear axle ring gear, 1914-1919 cars (No. 252), (wt. 5 lbs.) **3.35**
- J7909—Propeller shaft pinion, 1914-1919 cars (No. 254), (wt. 1 1/2 lbs.) **1.95**
- J7917—Differential gear (No. 242), (wt. 1 lb.) **2.10**
- J7918—Differential spider pinion (No. 245), (8 oz.) **.85**

Extra Quality Front Spring

Will be welcomed by every Ford owner who has had any trouble

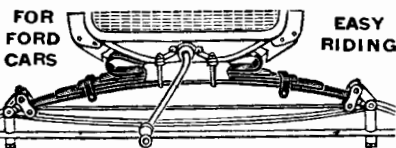

EASY RIDING

with breaking front springs. Has seven leaves of highest-grade, well tempered steel, with a special curl arrangement in the center which prevents excessive rebound, making the spring easy-riding, but at the same time almost unbreakable. Protects motor and tires from the effect of rough roads. Satisfaction guaranteed.

W8449—Front Spring (ship wt., 21 lbs.) **3.35**

High and Low Speed Gears

FOR FORD CARS

The use of special gear ratios on Ford cars is approved by all mechanics. In fact, Ford sedans are now equipped at the factory with a 4-to-1 ratio, since this gives far more power for the heavier car than the regular 3 1/2-to-1 ratio. This makes them very desirable also for trucks, and Fords used in mountains or on sandy roads. Gives more power, but slightly reduces speed.



For lighter cars, we recommend our 3-to-1 gears because they will give more speed with decreased cost for gasoline and oil consumption. They are as suitable for country roads as for city driving, and under general conditions will develop a speed of 55 miles or more an hour.

The gears we offer are the highest quality, forged gears, and can be depended on for service. Interchangeable with present gears and guaranteed to fit.

- J7783—Set, 3-to-1 (Shipping weight 5 lbs.) **4.95**
- J7784—Set, 4-to-1 (Shipping weight 5 lbs.) **3.85**

Differential Gears and Parts

For Ford Cars



A differential with loose, noisy gears is not only annoying but is dangerous, as something may break and lock the axle when you are driving fast, causing you a serious accident. Order a supply of gears and parts, fix it up yourself and save a big repair bill.

- 2518—Diff. Drive Gear, 40-tooth (wt. 4 lbs.) **1.95**
- 2520B—Diff. Side Gear, 24-tooth (wt. 1 1/2 lbs.) **.82**
- 2524C—Diff. Spider Pinion, 12-tooth (wt. 8 oz.) **.23**
- 2597B—Drive Shaft Pinion, 11-tooth (wt. 1 lb.) **.60**
- 2597C—Drive Shaft Pinion, 10-tooth for Sedan and light delivery (wt. 1 lb.) **.78**
- 2528—Diff. Thrust Plate (babbitt), (wt. 8 oz.) **.12**
- 2529—Diff. Thrust Plate (steel) **8c**
- 2526B—Diff. Spider (wt. 1 1/4 lbs.) **.55**

Motor Crib

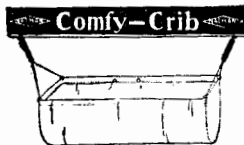

Take baby on the drive in a "Comfy-Crib." More comfortable for the baby and for the mother, too. Lets mother drive her own car in perfect safety with the baby snug and safe within arm's reach. Strong metal frame is suspended on spiral springs from top

bow. Hammock is of dark gray auto cloth, easily removed for washing. Inexpensive, substantial.

A5185—Motor Crib (shipping weight, 10 lbs.) **2.95**

Handy Garage Door Brace

SAVES YOUR FENDERS

A convenient, practical garage door brace that prevents doors from blowing shut and getting broken or injuring car. To hold the door open, simply press brace down with your foot—will hold door open in any position. To release door, raise brace with foot. When not in use, it folds up and heavy spring holds it securely out of the way. Length about 12 inches. Ship. wt., pair, 3 lbs.

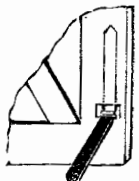

K8123—Pair, complete with screws for attaching **.65**

Regular Pistons for Ford Cars

89c MAKE THE OLD MOTOR RUN LIKE NEW BY RENEWING PISTONS

Each

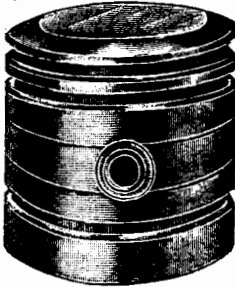

These pistons are made from the very highest grade close grained gray iron, regulation weight as now used in all Ford cars, ground to size, which not only insures the size being right, but means that each piston is exactly round. It is best to buy piston without rings; then put on some better rings. When renewing piston, always get full set to insure uniformity. Pistons come with pins and bushings, less rings; if pistons are worn it means endless trouble and expense. Shipping weight, 2 1/2 lbs., each.

Our Reduced Price

K8010—Regular Ford Size Piston, each.....	.89
K8011—.0025 Oversize for Worn Cylinders, each.....	.89
K8013—.005 Oversize (next oversize above .0025).	.89
K8012—.031 Oversize for Rebored Cylinders, each.....	.89

SUPER QUALITY STEP CUT PISTON RINGS FOR ALL CARS

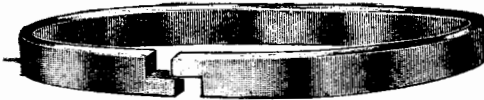

High-grade, individually cast piston rings in all popular sizes. Well-made of best material, accurately machined to the proper size. We do not handle the cheap low grade rings offered by others for slightly less price. All rings are furnished in .0025 oversize to allow for a slightly worn motor. If the ring is too large you can cut it down by filing the ends a little. Shipping weight, 5 oz.

Number	Size	Price	Number	Size	Price
K8258	2 3/4 x 3/4	.14	K8267	3 1/4 x 3/4	.14
K8259	2 1/2 x 3/4	.14	K8268	3 3/8 x 3/4	.14
K8260	2 1/8 x 3/4	.14	K8269	3 1/2 x 3/4	.14
K8261	3 x 3/4	.14	K8270	3 1/2 x 3/4	.14
K8262	3 1/8 x 3/4	.14	K8271	3 3/4 x 3/4	.14
K8263	3 1/4 x 3/4	.14	K8272	4 x 3/4	.14
K8264	3 3/8 x 3/4	.14	K8273	4 1/8 x 3/4	.14
K8265	3 1/2 x 3/4	.14	K8274	4 1/4 x 3/4	.14
K8266	3 5/8 x 3/4	.14			

Hudco-Ford Transmission Cover Lets You Reline Bands in 20 Minutes

A complete transmission cover that replaces the regular Ford cover. Has a removable section which makes it easy to change your transmission bands without taking off whole cover. Saves expense, beside all the trouble and delay of tying up your car. Lets you change one band at a time if desired.

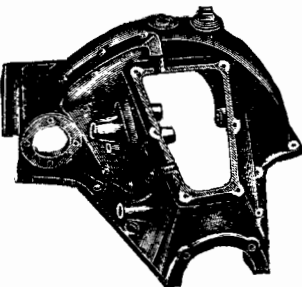

Also has a removable plug in top of cover which provides an easy means of reaching and cleaning out the Ford oil pipe.

Made of highest grade material throughout. Will outlast a dozen Fords. You can save your old cover, and if you sell or trade your car, simply change back. Anyway the Hudco-Ford will more than pay for itself in savings made on two changes of bands. Not an experiment, but thoroughly tested in actual use. Satisfaction guaranteed. Ship. wt., 40 lbs. Regular price, \$12.00.

K8839—Cover complete. Our Reduced Price.. 7.95

Never-Leak Piston Rings



Never-Leak Piston Rings are a three-piece ring, the pieces locking into each other without open joints, a construction which mechanics agree is the best design for securing high compression and preventing loss of power. They make every drop of gasoline count, and this means a saving in fuel consumption.

The three-piece construction of Never-Leak Rings also makes them quicker seating, especially in a cylinder that is slightly out of round. By fitting the cylinder walls closely, they make it almost impossible for oil to get by, and thus prevent the accumulation of carbon in the firing chamber, with all the trouble that carbon gives.

Made of the very finest grade material, accurately machined. Satisfaction guaranteed. Ship. wt., each, 4 oz.

Regular list price \$1.00.

Our Reduced Price

K7972—Regular size, for Ford, each.....	.62
K7973—.0025 oversize, for Ford, each.....	.62
K7974—.031 oversize, for Ford, each.....	.62
K7975—.005 Oversize for Ford, each.....	.62

Furnished only for Ford cars as listed

Bog Piston Ring Compressor

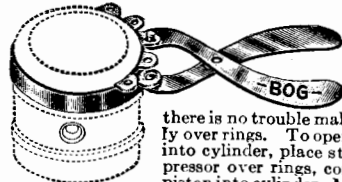

A high quality piston ring compressor that does the work quickly and easily. Band is wide enough, that

there is no trouble making it fit smoothly over rings. To operate, insert piston into cylinder, place steel band of compressor over rings, compress and push piston into cylinder. Made from highest

grade steel throughout and guaranteed to stand up under heavy strain. Fits all rings from 2 1/4 to 4 1/4 inches in diameter. Shipping weight, 1 lb.

H7574—Our Reduced Price..... .35

Piston Ring Compressor



With this compressor,

piston rings can be set in just a fraction of the time ordinarily consumed. A slight hand pressure on handles procures a leverage strong enough to compress even the new and stiff rings with very little effort. Fits rings from 3 to 4 inches in diameter. Shipping wt., 1 lb. H7557—Each.... .15

Piston Ring Expanders

Are placed under any make of piston ring and are provided with resilient shoulders, which push the piston rings outward into the right position, making perfect contact on the entire surface wall of the cylinder.

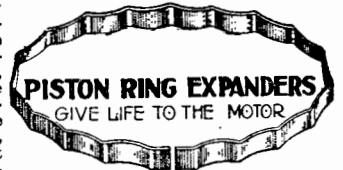

PISTON RING EXPANDERS
GIVE LIFE TO THE MOTOR

By increasing cylinder compression Piston Ring Expanders save oil and gasoline, reduce carbon deposits and vibration, and cure piston slaps. New or old motors equipped with them accelerate more easily and rapidly and throttle down lower.

Piston Ring Expanders are made of the highest grade material obtainable, are not affected by the heat of the motor, and will retain their resiliency indefinitely.

Shipping weight, each, 2 oz.	
K8075—For any 1-inch ring, each.....	.13
K8076—For any 1 1/2-inch rings, (Ford size), each.....	.13
Lots of 12, either size.....	1.28

OIL GROOVE PISTON RINGS



This is a brand new one-piece piston ring that combines all the advantages of the regular "step cut" ring with that of the high-priced oil groove rings.

The step cut joint insures a greater flexibility, better compression, more power, less carbon, and greater gasoline and oil economy. The oil groove cut near the bottom of each ring seals compression and prevents oil from going by the pistons into the cylinders. Note particularly the bevelled upper edge, which gives the ring a "pump-like action"—sliding up **over** the oil and pumping it **down**.

You know oil does not explode like gasoline—it burns and the result is the formation of carbon on the cylinder domes, piston heads, spark plugs, valve seats, and behind the piston rings.

The best remedy for carbon is prevention. A smoking exhaust is conclusive evidence that oil is passing the piston rings, and an indication that engine troubles are sure to follow unless promptly remedied. The average motorist

too often overlooks the great importance of proper piston rings—too much carbon, pre-ignition, knocking, loss of power, over-consumption of oil and gasoline can be traced directly to faulty piston rings in a great majority of cases.

In offering the Step Cut Oil Groove Ring we feel that we are filling the long-felt need for a high-grade, effective, leak-proof ring at a very reasonable price. Carefully made of best material, accurately finished, properly sized, concentric type.

Just as easy to install as a regular ring. Four of these rings, one for the top groove of each piston, will make a great improvement, but we recommend a full set of 12 rings. Shipping weight, each, 4 oz. Furnished in regular and over sizes.

Our Reduced Price

K7982—Ford size, regular, 3¼x¼.....	18
K7988—Ford size, 3¼x¼ plus .0025 oversize.....	18
K7989—Ford size, 3¼x¼ plus .005 oversize.....	18
K7985—Ford size, 3¼x¼ plus .031 oversize.....	18

OIL GROOVE RINGS FOR ALL CARS

All the following sizes are furnished in .0025 oversize to allow for slightly worn cylinders. If they are a little too large, just touch up the joints with a file until they fit satisfactorily:

X8737—3⅝x¼.....	20	X8725—3¼x¼.....	20	X8731—3¼x¼.....	20
X8720—2⅝x¼.....	20	X8726—3¼x¼.....	20	X8732—3¼x¼.....	20
X8721—2⅝x¼.....	20	X8727—3¼x¼.....	20	X8733—3¼x¼.....	20
X8722—2⅝x¼.....	20	X8728—3¼x¼.....	20	X8734—3¼x¼.....	20
X8723—2⅝x¼.....	20	X8729—3¼x¼.....	20	X8735—3¼x¼.....	20
X8724—3 x ¼.....	20	X8730—3⅝x¼.....	20	X8736—4 x ¼.....	20

Genuine "No-Leak-O" Piston Rings



The cylinder walls of all gasoline motors warp from expansion and contraction; they also wear. As a piston ring cannot conform to these irregular surfaces, the explosion and other forces destroy the level of oil as it passes over these places; the gas escapes and oil passes up. "No-Leak-O" Rings are constructed with a 45-degree angle-groove which fills with oil between the ring and the cylinder wall; this oil pulsates as the piston moves up and down. This pulsation **KEEPS** a film of oil between the ring and the cylinder wall regardless of these warped or worn places on the cylinder walls. This gives the motor maximum power all the time. "No-Leak-O" Rings are carefully made from a special formula close-grained tough gray iron, concentric individually cast and accurately finished, making them very durable and capable of long wear. Over 20,000,000 now in use. One of the best one-piece rings ever made.

Easy to install. One of these rings on the top groove of each piston will make a very noticeable improvement in the power of your motor. A full set will make your car a regular "bear cat" on hills. Weight, each, 4 oz.

K7991—Ford Size, Reg. 3¼x¼.....	32	K8052—2⅝x¼.....	32	K8059—3⅝x¼.....	32
K7992—Ford Size, 3¼x¼, plus .0025 oversize.....	32	K8053—2⅝x¼.....	32	K8060—3⅝x¼.....	32
K7994—Ford Size, .005 oversize.....	32	K8054—3 x ¼.....	32	K8061—3⅝x¼.....	36
K7993—Ford Size; .031 oversize.....	32	K8055—3⅝x¼.....	32	K8062—3¼x¼.....	32
K8048—3⅝x¼.....	32	K8056—3¼x¼.....	32	K8063—3¼x¼.....	32
K8050—2⅝x¼.....	32	K8057—3⅝x¼.....	32	K8064—3⅝x¼.....	32
K8051—2⅝x¼.....	32	K8049—3⅝x¼.....	32	K8065—4x¼ (Fordson Tractor).....	36

All rings, except Ford sizes, are regular standard size (not oversize).

PISTON RINGS FOR FORD CARS



Mitre-Cut Piston Rings.

The material used in these rings is a secret mixture of metals, resulting in a springy ring not affected by heat, and a close grain that adds strength and long-wearing qualities, besides reducing friction materially. Shipping weight, each, 4 oz.

Our Reduced Price

K7960—Mitre Ring, regular size.....	9c
K7962—Mitre Ring, .031 oversize.....	9c
K7961—Mitre Ring, .0025 oversize.....	9c



Lap-Joint Piston Rings

The lap-joint ring holds compression much better than the regular open type. The quality of our rings cannot be excelled by any ring on the market—you can depend on them for service. Shipping weight, each, 4 oz.

K7966—Lap-Joint Ring, regular size.....	11
K7967—Lap-Joint Ring, .025 oversize.....	11
K7969—Lap-Joint Ring, .005 oversize.....	11
K7968—Lap-Joint Ring, .031 oversize.....	11

Rear Hub Brake Parts

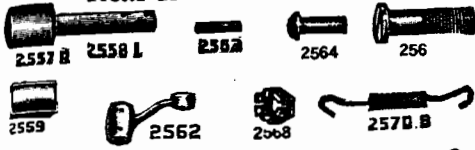

- 2557 Hub cam shaft—right, (wt. 3 oz.) 9c
- 2558 Hub cam shaft—left, (wt. 3 oz.) 9c
- 2559 Hub cam shaft bushing, (wt. 4 oz.) 9c
- 2562 Hub cam shaft lever, (wt. 4 oz.) 9c
- 2563 Hub cam shaft lever pin, (wt. 2 oz.) 2c
- 2564 Lever clevis pin, (wt. 2 oz.) 2c
- 2566 Hub brake shoe See Index
- 2567 Brake shoe support bolt and nut, (wt. 4 oz.) 6c
- 2568 Brake shoe support nut, (wt. 2 oz.) 6c
- 2570B Brake shoe coil spring, (wt. 2 oz.) 2c

Drive Shaft Bearings—Cont.

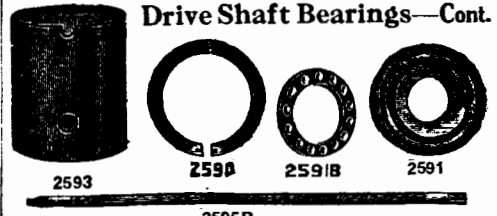

- 2593 D. S. roller bearing sleeve, 1911-21 1.40
- 2595B Drive shaft only 1911-24, (wt. 14 lbs.) 1.00
- 2596 D. S. sleeve, 1" bore, 3 1/8" long, (wt. 12 oz.)40
- 2597B D. S. pinion, standard 11 tooth60
- 2597C D. S. pinion, low gear, 10 tooth60
- 2598 D. S. castle nut, (wt. 2 oz.) 6c
- 2598B D. S. pinion key, (wt. 2 oz.) 4c

Universal Joint Parts

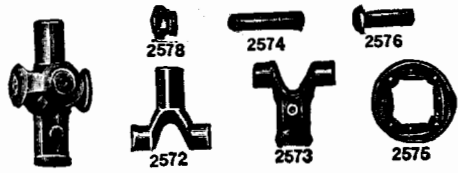

- 2571 Universal joint assembly, (wt. 3 lbs.) 1.28
- 2572 Joint knuckle (male), (wt. 1 lb.)42
- 2573 Joint knuckle (female), (wt. 1 lb.)45
- 2574 Joint knuckle pin, (wt. 2 oz.) 2c
- 2575 Joint ring, complete, (wt. 1 lb.)42
- 2576 Joint ring rivets (per set of 4), (wt. 2 oz.) 4c
- 2577B Joint housing, (wt. 2 lbs.), 1914-2485
- 2578 Joint housing plug, (wt. 2 oz.) 3c
- 2579 Ball joint grease cup, (wt. 4 oz.)12
- 2580 Ball cap gasket, felt, (wt. 2 oz.) 4c
- 2581 Drive shaft housing front bushing, 1" bore, babbitt, (wt. 8 oz.)22

Front Axle Parts

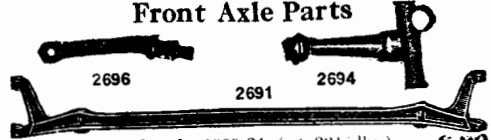

- 2691 Front axle only, 1909-24, (wt. 22 1/2 lbs.) 6.90
- 2694B Spindle body right, without cones and washer (ship wt. 3 lbs.) 1.05
- 2695B Spindle body left, with out cones and washer, (ship wt. 3 lbs.) 1.05
- 2694 Spindle body—right, 1911-24, (wt. 3 lbs.) with cones, washer and nut 1.25
- 2695 Spindle body—left, 1911-24, (wt. 3 lbs.) with cones, washer and nut 1.25
- 2696C Spindle arm—right, 1919-24, (wt. 12 oz.)34
- 2696D Spindle arm—left, 1919-24, (wt. 12 oz.)34
- For cars prior to 1919, order spindle arms 2696C and 2696D, in pairs.
- 2697 Spindle arm nut, (wt. 2 oz.) 4c

Drive Shaft Parts

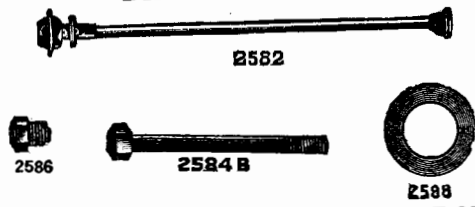

- 2582 D. S. tubing, (wt. 20 lbs.) 5.65
- 2583 D. S. Roller bearing housing, 1909-20 1.29
- 2583B Drive Shaft bearing housing 1920-24 4c
- 2584B D. S. roller bearing cap screw, 1912-22 4c
- 2586 D. S. roller bearing housing set screw, 1911-20, 1/2" x 20 thds., (wt. 2 oz.) 4c

Front Spindle Cones

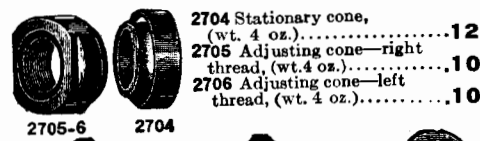

- 2704 Stationary cone, (wt. 4 oz.) 12
- 2705 Adjusting cone—right thread, (wt. 4 oz.) 10
- 2706 Adjusting cone—left thread, (wt. 4 oz.) 10
- 2705-6 Spindle nut—right thread, (wt. 2 oz.) 5c
- 2707R Spindle nut—left thread, (wt. 2 oz.) 5c
- 2708L Spindle washer, (wt. 2 oz.) 2c
- 2709 Spindle washer, (wt. 2 oz.) 2c

Drive Shaft Bearings

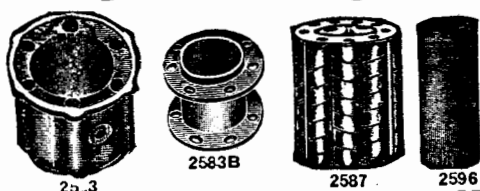

- 2587 D. S. roller bearing, (wt. 1 1/4 lbs.)85
- 2588 D. S. roller bearing distance plate, 1911-21, 2 1-32" diameter, (wt. 2 oz.) 3c
- 2589 D. S. ball race, 1911-2116
- 2589B D. S. ball bearing assembly, 1911-2155
- 2590 D. S. ball retainer, 1911-21 2c
- 2591 D. S. ball thrust collar, 1911-2419
- 2591B D. S. thrust ball and retainer assembly 1920-2417
- 2592 D. S. ball bearings, each 2c

Spindle Bolts

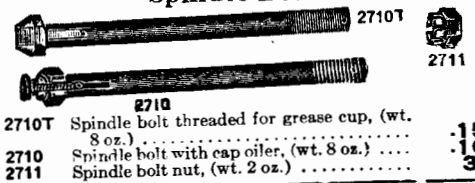

- 2710T Spindle bolt threaded for grease cup, (wt. 8 oz.)15
- 2710 Spindle bolt with cap oiler, (wt. 8 oz.)16
- 2711 Spindle bolt nut, (wt. 2 oz.) 3c

Steering Gear Bushings

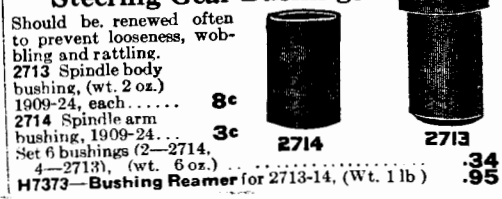

- Should be renewed often to prevent looseness, wobbling and rattling.
- 2713 Spindle body bushing, (wt. 2 oz.) 8c
- 1909-24, each 8c
- 2714 Spindle arm bushing, 1909-24 3c
- Set 6 bushings (2—2714, 4—2713), (wt. 6 oz.) 3c
- H7373—Bushing Reamer for 2713-14, (Wt. 1 lb)95

Steering Rod Parts

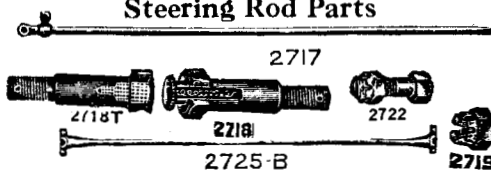

- | | | | |
|-------|---|-------|------|
| 2717 | Spindle con. rod, 46 $\frac{3}{4}$ " long, (wt. 3 $\frac{1}{2}$ lbs.) | 2719 | 1.35 |
| 2718T | Spindle arm bolt, threaded for grease cup | 2804 | .13 |
| G7015 | Grease cup for bolt (3/4"), (wt. 2 oz.) | 2805 | .6c |
| 2718 | Spindle arm bolt with cap oiler (wt. 4 oz.) | 2805A | 1.3c |
| 2719 | Spindle con. rod bolt nut, (wt. 2 oz.) | 2806 | .13 |
| 2721B | Spindle con. rod yoke ball, 1919-24 (wt. 4 oz.) | 2807 | .2c |
| 2721C | Spindle con. rod yoke, 1919-24 (wt. 6 oz.) | 2808 | .16 |
| 2725B | Steering gear con. rod, 1903-24, (2 $\frac{1}{2}$ lbs.) | 2809 | .33 |
| 2728 | Ball socket cap, 1909-24, (wt. 2 oz.) | 2810 | .65 |
| 2729B | Ball socket bolt and nut, (wt. 2 oz.) | 2811 | 8c |

Front Radius Rod Parts

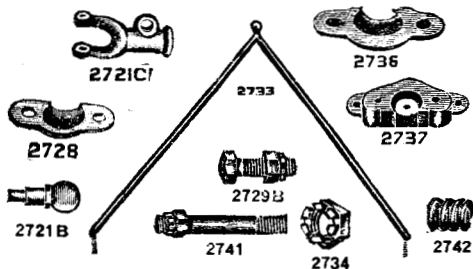

- | | | |
|-------|---|------|
| 2733 | Front radius rod, 1909-19, (wt. 10 lbs.) | 1.38 |
| 2733B | Front radius rod, 1919-24, (wt. 10 lbs.) | 1.18 |
| 2734 | Front radius rod nut, (wt. 2 oz.) | 4c |
| 2736 | Front radius rod ball cap, (wt. 2 oz.) | 8c |
| 2737 | Front radius rod ball socket, (wt. 8 oz.) | .16 |
| 2741 | Radius rod ball cap stud and nut, (4 oz.) | 4c |
| 2742 | Radius rod ball cap spring, (wt. 2 oz.) | 2c |
| 2853 | Front cross member, (wt. 4 lbs.) | .7 |
| 2854B | Rear cross member, 1914-24, (wt. 8 lbs.) | 1.92 |
| 2855 | Front corner bracket, right, (wt. 8 oz.) | .19 |
| 2856 | Front corner bracket—left, (wt. 8 oz.) | .19 |
| 2857 | Rear corner bracket, right, (wt. 8 oz.) | .19 |
| 2858 | Rear corner bracket—left, (wt. 8 oz.) | .19 |

Wheels and Parts

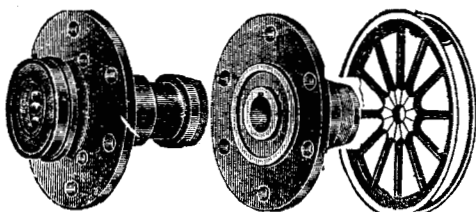

- | | | |
|-------|--|------|
| 2800D | Front wheel without hub, 30x3, (wt. 17 lbs.) | 2.95 |
| 2803 | Front hub complete with ball bearings, less flange, 1909-24, (wt. 5 lbs.) | 1.22 |
| 2803X | Front hub only, less bearings (for use with roller bearings) | .95 |
| 2814D | Rear wheel without hub, (wt. 17 lbs.) | 2.95 |
| 2815C | REAR HUB less flange, 1911-24, (4 lbs.) | .98 |
| W8401 | Black demountable wheel without rim or hub; will fit any rim used as standard equipment on Ford cars, size 30x3 $\frac{1}{2}$, each (wt. 18 lbs.) | 2.95 |
| W8399 | Dem. rim, Hayes (with lugs attached) | 1.40 |

Hub and Wheel Parts

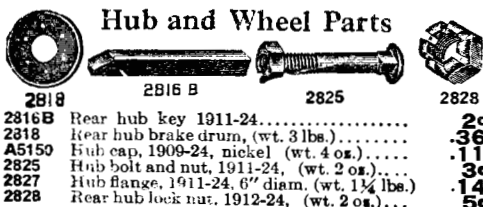

- | | | |
|-------|--|-----|
| 2816B | Rear hub key 1911-24 | 2c |
| 2818 | Rear hub brake drum, (wt. 3 lbs.) | .36 |
| A5150 | Hub cap, 1909-24, nickel (wt. 4 oz.) | .11 |
| 2825 | Hub bolt and nut, 1911-24, (wt. 2 oz.) | .3c |
| 2827 | Hub flange, 1911-24, 6" diam. (wt. 1 $\frac{1}{4}$ lbs.) | .14 |
| 2828 | Rear hub lock nut, 1912-24, (wt. 2 oz.) | 5c |
| 3003 | Cyl. head cap screw, 1909-17, 2.9-16" long | 4c |
| 3003B | Cyl. head cap screw, 1917-24, 3 $\frac{1}{4}$ " long | 4c |
| 3004 | Cyl. head outlet con., 1909-16, (wt. 11 oz.) | .24 |
| 3004B | Cyl. head outlet con., 1917-24, (wt. 11 oz.) | .23 |
| 3005 | Cyl. head outlet con. gasket, (wt. 1 oz.) | 4c |
| 3008 | Cyl. head outlet con. screw, (wt. 2 oz.) | 3c |

Front Wheel Bearings

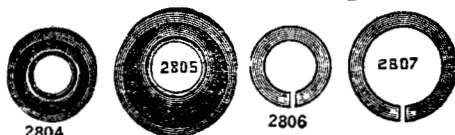

- | | | |
|-------|---|------|
| 2804 | Outer race, (wt. 2 oz.) | 7c |
| 2804A | Outer race assembly with balls, (wt. 8 oz.) | 1.26 |
| 2805 | Inner race, (wt. 5 oz.) | .10 |
| 2805A | Inner race assembly with balls, (wt. 1 lb.) | .32 |
| 2806 | Outer ball retainer, (wt. 2 oz.) | 2c |
| 2807 | Inner ball retainer, (wt. 2 oz.) | 2c |
| 2808 | Dust ring, steel, 2 $\frac{1}{4}$ " diameter, (wt. 2 oz.) | 2c |
| 2809 | Front and rear hub felt washer, 1909-24 | 2c |
| 2810 | Large balls, 1/2" each | 2c |
| 2811 | Small balls, 3/8" each | 2c |

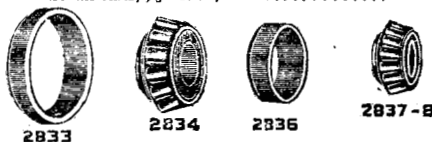

- | | | |
|------|--|------|
| 2833 | Front hub roller bearing cup, inner | 4c |
| 2834 | Inside cone and roller assembly | 1.20 |
| 2836 | Front hub roller bearing cup, outer | 4c |
| 2837 | Outside cone and roller assembly, right thread | 1.20 |
| 2838 | Outside cone and roller assembly, left thread | 1.20 |

Frame and Parts

- | | | |
|-------|--|------|
| 2853 | Front cross member, (wt. 4 lbs.) | .7 |
| 2854B | Rear cross member, 1914-24, (wt. 8 lbs.) | 1.92 |
| 2855 | Front corner bracket, right, (wt. 8 oz.) | .19 |
| 2856 | Front corner bracket—left, (wt. 8 oz.) | .19 |
| 2857 | Rear corner bracket, right, (wt. 8 oz.) | .19 |
| 2858 | Rear corner bracket—left, (wt. 8 oz.) | .19 |

Gasoline Tank and Parts

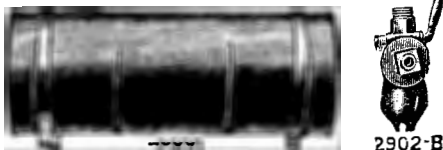

- | | | |
|-------|--|------|
| 2900B | Sedan gasoline tank, (square) | 5.45 |
| 2900C | Gasoline tank, (oval), 10 gals. (wt. 20 lbs.) | 3.55 |
| 2901 | Gas tank cap, 2 $\frac{1}{4}$ ", (wt. 2 oz.) | 8c |
| 2902B | Sediment bulb, with pet cock, (wt. 1 lb.) | .82 |
| 2908 | Pet cock, brass, (wt. 2 oz.) | .12 |
| 2909 | Feed pipe, 1/2"x40 $\frac{1}{2}$ " long, (wt. 4 oz.) | .17 |
| 2910 | Feed pipe pack nut, (wt. 2 oz.) | 4c |

Motor Parts

- | | | |
|--|---|-------------|
| 3000C | New cylinder block fitted for starter, (wt. 86 lbs., unavailable) | 22.45 |
| Note —When ordering cylinder block for old style car not equipped with starter, also order one each, 3008, 3011, 3016, 3017B and 3017C. | | |
| 3001 | Cylinder head, 1909-24, (wt. 35 lbs.) | 4.95 |
| 3002 | Cylinder head gasket | See Page 99 |

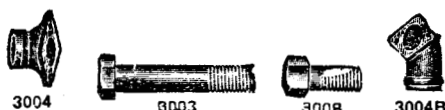

- | | | |
|-------|--|-----|
| 3003 | Cyl. head cap screw, 1909-17, 2.9-16" long | 4c |
| 3003B | Cyl. head cap screw, 1917-24, 3 $\frac{1}{4}$ " long | 4c |
| 3004 | Cyl. head outlet con., 1909-16, (wt. 11 oz.) | .24 |
| 3004B | Cyl. head outlet con., 1917-24, (wt. 11 oz.) | .23 |
| 3005 | Cyl. head outlet con. gasket, (wt. 1 oz.) | 4c |
| 3008 | Cyl. head outlet con. screw, (wt. 2 oz.) | 3c |

Motor Parts

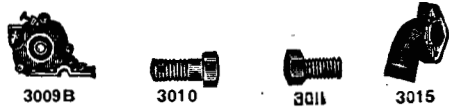

- | | | |
|-------|---|-----|
| 3009B | Cyl. front cover, (wt. 2 lbs.), 1909-19..... | .90 |
| 3009C | Cyl. front cover—starter type, 1919-24, (wt. 2 lbs.)..... | .85 |
| 3010 | Cyl. cover bolt and nut, (1 oz.)..... | 5c |
| 3011 | Cyl. cover cap screw, (wt. 2 oz.)..... | 3c |
| 3012 | Cyl. cover felt, (wt. 2 oz.)..... | 3c |
| 3013 | Cyl. cover liner, paper..... | 2c |
| 3013B | Cyl. cover liner, paper starter type..... | 2c |



- | | | |
|------|---|-----|
| 3014 | Cyl. cover and crank case bolt and nut, $\frac{3}{8}$ "x $1\frac{1}{4}$ ", (wt. 2 oz.)..... | 5c |
| 3015 | Cyl. water inlet connection, (wt. 2 oz.)..... | .24 |
| 3016 | Cyl. inlet con. screw (wt. 3 oz.)..... | 3c |

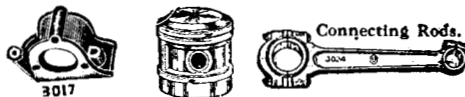

- | | | |
|-------|--|-------------------|
| 3017 | Time gear cover, 1919-24, starter type, (wt. 1 lb.)..... | .72 |
| 3017B | Time gear cover (for use with old models)..... | .72 |
| 3017C | Time gear cover gasket, 1919-24..... | 1c |
| 3017D | Time gear cover plate, 1919-24..... | 5c |
| 3018 | Cyl. water inlet gasket, (wt. 2 oz.)..... | 3c |
| 3019 | Cyl. water jacket plug, 1914-24..... | 2c |
| 3020 | Pistons without rings..... | See Page 88 |
| 3022 | Piston pin, (wt. 4 oz.)..... | .18 |
| 3022½ | Piston pin bushing, pair, (3 oz.)..... | .16 |
| H7374 | Reamer for 3022½ bushing, (wt. 1 lb.)..... | See Page 113 |
| 3023 | Piston rings..... | See Pages 88 & 89 |
| 3024 | Connecting rod complete..... | See Page 86 |



- | | | |
|-------|---|----|
| 3025 | Connecting rod cap bolt and nut, (wt. 2 oz.)..... | 5c |
| 3026 | Connecting rod cap bolt nut, (wt. 2 oz.)..... | 3c |
| 3029 | Connecting rod clamp screw, (wt. 2 oz.)..... | 3c |
| 3028X | Connecting rod shim..... | 1c |



- | | | |
|-------|--|------|
| 3030 | CRANK SHAFT, 1909-24, (wt. 17 lbs.)..... | 6.90 |
| 3031 | C. S. rear bearing cap, (1 lb.)..... | .45 |
| 3032 | C. S. front bearing cap, (10 oz.)..... | .35 |
| 3033 | C. S. center bearing cap, (10 oz.)..... | .35 |
| 3034 | C. S. bearing bolt—center and front, $\frac{1}{2}$ "x $6\frac{1}{2}$ ", (6 oz.)..... | 7c |
| 3035 | C. S. bearing bolt nut, (wt. 2 oz.)..... | 3c |
| 3036 | C. S. rear bearing bolt, (wt. 4 oz.)..... | 7c |
| 3038 | C. S. bearing shim—center and front..... | 1c |
| 3039 | C. S. rear bearing shim..... | 1c |
| 3040 | C. S. starting pin, (2 oz.) 1909-20..... | 3c |
| 3040B | C. S. starting pin 1920-24 (2 oz.)..... | 4c |

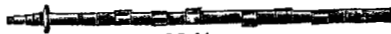

- | | | |
|------|---|------|
| 3041 | CAM SHAFT, 1909-24, (wt. 3½ lbs.)..... | 2.28 |
| 3042 | Cam shaft front bearing, babbitt lined, (wt. 6 oz.)..... | .32 |
| 3043 | Cam shaft center bearing, babbitt lined, (wt. 6 oz.)..... | .32 |
| 3044 | Cam shaft rear bearing, (3 oz.)..... | .11 |
| 3045 | Cam shaft bearing ring, (wt. 2 oz.)..... | 3c |
| 3046 | Cam shaft bearing set screw, (wt. 1 oz.)..... | 3c |

Motor Parts

- | | | |
|-------|--|-----|
| 3047B | Time gear—large, spiral, (wt. 2 lbs.)..... | .69 |
| 3048B | Time gear—small, spiral, (wt. 1 lb.)..... | .49 |
| 3049 | Cam shaft gear dowel pin..... | 2c |

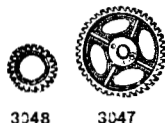

- | | | |
|-------|---|-----|
| 3050B | Cam shaft gear lock nut, (wt. 2 oz.)..... | 8c |
| 3051 | Small time gear key..... | 3c |
| 3052 | Valve, exhaust and inlet, (3 oz.)..... | .10 |
| 3052B | Valve, ½" oversize stem..... | .10 |
- See page 105 for Super Quality Steel Valve



- | | | |
|-------|---|------|
| 3053½ | Valve bushing, (2 oz.)..... | 22 |
| H7376 | Reamer for installing ½" oversize valve, (wt. 1 lb.)..... | 1.29 |
| 3054 | Valve spring (2 oz.)..... | 3c |
| 3056 | Valve spring seat, per set of 8, (wt. 2 oz.)..... | 4c |
| 3057 | Valve spring seat pin, per set of 8, (2 oz.)..... | 4c |
| 3058 | Push rod, (2 oz.)..... | 8c |
| 3058B | Push rod, 1-64" oversize stem, (2 oz.)..... | 9c |
| 3059½ | Push rod bushing, iron, (wt. 2 oz.)..... | .22 |







- | | | |
|-------|---|------|
| 3060B | Exhaust manifold, 1913-24, (wt. 4½ lbs.)..... | 1.12 |
| 3061 | Exhaust pipe pack nut, (4 oz.)..... | .15 |







- | | | |
|-------|--|-----|
| 3062 | Inlet and exhaust pipe gasket, (wt. 1 oz.)..... | .85 |
| 3063 | Inlet and exhaust pipe gland, (wt. 1 oz.)..... | 2c |
| J7729 | Combination of 3063 and 3064 gasket and gland, (wt. 2 ozs.)..... | 4c |
| 3064 | Inlet and exhaust pipe gland, (wt. 2 oz.)..... | 1c |
| 3065 | Inlet and exhaust pipe clamp (wt. 4 oz.)..... | 7c |
| 3066 | Inlet and exhaust clamp stud and nut, (wt. 2 oz.)..... | 5c |
| 3068 | Breather pipe cap, (wt. 2 oz.)..... | 7c |
| 3069B | Crank case front end support, (wt. 1½ lbs.) 1911-17..... | .95 |
| 3069C | Crank case front end support, (wt. 1½ lbs) 1917-24..... | .52 |
| 3070 | Crank case and cyl. gasket—L..... | 4c |
| 3071 | Crank case and cyl. gasket—R..... | 4c |
| 3072 | Crank case and cyl. cover cap screw, (wt. 2 oz.)..... | 3c |
| 3073 | Crank case arm bolt and nut—side (2 oz.)..... | 5c |
| 3074 | Crank case arm bolt and nut—top (2 oz.)..... | 4c |



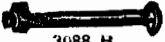

- | | | |
|-------|--|-----|
| 3062 | Inlet pipe, 1909-24, (wt. 2½ lbs.)..... | .85 |
| 3063 | Inlet and exhaust pipe gland, (wt. 1 oz.)..... | 2c |
| J7729 | Combination of 3063 and 3064 gasket and gland, (wt. 2 ozs.)..... | 4c |
| 3064 | Inlet and exhaust pipe gland, (wt. 2 oz.)..... | 1c |
| 3065 | Inlet and exhaust pipe clamp (wt. 4 oz.)..... | 7c |
| 3066 | Inlet and exhaust clamp stud and nut, (wt. 2 oz.)..... | 5c |
| 3068 | Breather pipe cap, (wt. 2 oz.)..... | 7c |
| 3069B | Crank case front end support, (wt. 1½ lbs.) 1911-17..... | .95 |
| 3069C | Crank case front end support, (wt. 1½ lbs) 1917-24..... | .52 |
| 3070 | Crank case and cyl. gasket—L..... | 4c |
| 3071 | Crank case and cyl. gasket—R..... | 4c |
| 3072 | Crank case and cyl. cover cap screw, (wt. 2 oz.)..... | 3c |
| 3073 | Crank case arm bolt and nut—side (2 oz.)..... | 5c |
| 3074 | Crank case arm bolt and nut—top (2 oz.)..... | 4c |

Motor Parts, Cont'd

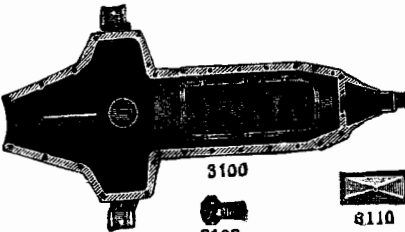

- | | | | | |
|--|---|---|---|-----|
|  |  |  |  | |
| 3076 | 3078 | 3080 | 3076B | |
| | | | | .45 |
| | | | | .54 |
| | | | | 4c |
| | | | | 8c |
| | | | | 4c |
| | | | | .12 |
| | | | | .15 |
| | | | | 2c |
| | | | | .18 |
| | | | | 4c |







- | | | | |
|---|---|--|-----|
|  |  | | |
| 3084 | 3085 | | |
|  |  | | |
| 3088 B | 3088 C | | |
| 3084 | Engine pan—right, (wt. 2 lbs.) | | .26 |
| 3085 | Engine pan—left, (wt. 2 lbs.) | | .26 |
| 3088B | Engine pan and hood board bolt and nut, (wt. 2 oz.) | | 3c |
| 3088C | Engine pan and hood board bolt and nut, (wt. 2 oz.) | | 3c |

Crank Case and Parts





- | | | | |
|---|---|--|------|
|  |  | | |
| 3100 | 3101 | | |
|  |  | | |
| 3103 | 8110 | | |
| 3100 | Crank case with lower cover, (wt. 25 lbs.) | | 9.90 |
| 3101 | Crank case lower cover, (3 lbs.) | | .28 |
| 3101B | C. S. lower cov. reinforcement, (2 lbs.) | | .20 |
| 3102 | Crank case lower cover gasket—felt | | 8c |
| 3103 | Crank case lower cover screw | | 2c |
| 3110 | Cylinder valve cover, (2 oz.) 1912-21 | | .16 |
| 3110B | Cylinder valve cover, 1921-24 | | .13 |
| 3111 | Cylinder valve cover gasket—felt 1912-21 | | 3c |
| 3111C | Cylinder valve cover gasket, 1921-24 (cork) | | .08 |
| 3112 | Cylinder valve cover screw, (2 oz.) | | 2c |
| 3114 | Crank case arm with rivets, (wt. 1 lb.) | | .27 |

Commutator Parts

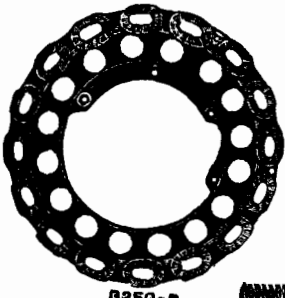

- | | | | |
|---|---|---|-----|
|  |  |  | |
| 3162 | 3163 | 3165 | |
| 3162 | Com. case support bolt, (wt. 2 oz.) | | 4c |
| 3162B | Com. case support bolt—starter type, (wt. 2 oz.) | | 4c |
| 3163 | Com. case spring, (wt. 2 oz.) | | 4c |
| 3165 | Com. brush assembly, (3 oz.) | | .16 |
| 3177 | Com. felt ring | | 2c |



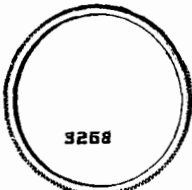

- | | | | | | | |
|--|---|---|---|---|---|----|
|  |  |  |  |  |  | |
| 3206 | 3207 | 3210 | 3212 | 3220 | 3222 | |
| | | | | | | 2c |
| | | | | | | 1c |
| | | | | | | 3c |
| | | | | | | 3c |
| | | | | | | 2c |

Magneto and Parts

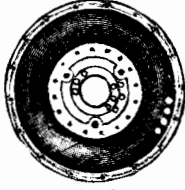
- | | | | | |
|---|---|--|--|------|
|  |  |  |  | |
| 3250D | 3252 | 3254 | 3255 | |
| | | | | 5.45 |
| | | | | 2c |
| | | | | 1c |
| | | | | 4c |
| | | | | 16c |
| | | | | 1c |
| | | | | 4c |

- | | | | |
|-------|---|--|-----|
| 3250D | Magneto coil assembly, 1915-24, (wt. 10 lbs.) | | |
| 3252 | Magneto spool support screw, (wt. 2 oz.) | | 2c |
| 3254 | Magneto bolt, 5/8" x 1 1/2" | | 1c |
| 3255 | Magnet bolt washer | | 4c |
| 3257 | Magnet braes support, (wt. 2 oz.) | | 16c |
| 3260 | Magneto contact assembly, (wt. 2 oz.) | | 1c |
| 3261B | Magneto contact nut | | 4c |
| 3261C | Magneto contact screw washer | | 1c |
| 3262 | Magneto contact spring, (wt. 2 oz.) | | 4c |

- | | | | |
|---|---|--|------|
|  |  |  | |
| 3266 | 3268 | 3269G | |
| 3266 | Magneto contact fiber screw | | 1c |
| 3268 | Fly wheel ring gear for starter, (wt. 5 lbs.) | | .84 |
| 3269C | Fly wheel less magnets, 1911-19 | | 5.35 |
| 3269G | Fly wheel only, starter type, 1919-24, (wt. 20 lbs.) | | 4.55 |

- | | | | | |
|--|--|--|---|------|
|  |  |  |  | |
| 3270 | 3271 | 3272 | 3277 | |
| 3270 | Fly wheel cap screw, (wt. 2 oz.) | | | 6c |
| 3271 | Fly wheel dowel pin, (wt. 2 oz.) | | | 4c |
| 3272 | Magneto coil support shim | | | 4c |
| 3276B | Magnet (16), per set, 1915-24, set, (wt. 18 lbs.) | | | 3.65 |
| 3277 | Magnet clamp, 1911-24, (wt. 2 oz.) | | | 3c |
| 3278 | Magnet clamp screw, (wt. 2 oz.) | | | 2c |
| 3279 | Magnet-contact washer, (wt. 2 oz.) | | | 1c |

Transmission Parts

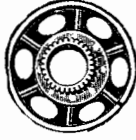
- | | | | |
|---|--|--|------|
|  |  | | |
| 3304 | 3301 | | |
| 3301 | Trans. reverse plate assembly, (wt. 5 lbs.) | | 1.95 |
| 3304 | Trans. reverse gear bushing, (wt. 10 oz.) | | .35 |
| 3305 | Trans. reverse and S.S. rivet, dozen, (wt. 2 oz.) | | 4c |

Ball Bearing Clutch Lever Bolt

- | | |
|--|---|
|  | |
| B5668 | Replaces Ford part No. 3403. Has ball bearing on end of bolt. Operates back and forth over the speed lever without friction, always keeping the engine free and the clutch clear, so that there is no drag when cranking car. |
| B5668 | Our Reduced Price, each |
| | .28 |

Transmission Parts—Cont.

3306	TRANS. SLOW SPEED PLATE ASSEMBLY, 1909-24, (wt. 5 lbs.)	1.95
3309	Trans. slow speed gear bush, (wt. 5 oz.)	.26
3310	Trans. brake drum rivet, (wt. 2 oz.) doz.	4c
3311	TRANS. BRAKE DRUM ASSEMBLY, 1909-24, (wt. 6 lbs.)	2.05
3313	TRANS. TRIPLE GEAR ASSEMBLY, 1909-24, (wt. 3 lbs.)	1.08
3314 1/2	Trans. triple gear flanged bushing, (4 oz.)	.16
3315	Trans. triple gear shaft, (wt. 4 oz.)	.12
3316	Trans. triple gear riveting pin per dozen	4c
3317	Trans. driven gear, (wt. 1 lb.)	.59
3318	Trans. driven gear key, (wt. 4 oz.)	3c
3320C	Trans. driven gear sleeve bushing, 1909-24 (wt. 3 oz.)	15
3320D	Driven gear sleeve washer (3 to car, must be used with 3311), (wt. 2 oz.)	3c
3321	TRANS. DRIVING PLATE ASSEMBLY, 1909-23, (wt. 5 lbs.)	2.65
3323	Trans. driving plate screw, (wt. 2 oz)	3c
3325	Trans. driving plate rivet, 1909-24, 1/2" x 5/8", per dozen, (wt. 2 oz.)	4c
3327B	Trans. driving plate bushing, (wt. 2 oz.),	.12
3328	Trans. thrust plate—small, (wt. 3 oz.)	6c
3329	Trans. thrust plate—large, (wt. 3 oz.)	6c
3331	Trans. gear shaft, (wt. 3 lbs.)	1.15
3332	Trans. clutch disc drum, 1909-23, 4 9-16" diameter, (wt. 2 lbs.)	.98
3333	Trans. clutch disc drum key, (wt. 2 oz.)	4c
3334	Trans. clutch disc drum set screw, (wt. 2 oz.)	4c
3336	Trans. clutch push ring, (wt. 1 lb.)	.28
3337	Trans. clutch finger, (wt. 3 oz.)	.12
3337 1/2	Trans. clutch finger screw	4c
3338	Trans. clutch finger pin, (wt. 1 oz.)	1c
3340	Trans. clutch spring, (wt. 1 lb.)	.19
3341	Trans. clutch spring support, (wt. 4 oz.)	8c
3342	Trans. clutch spring thrust ring pin,	2c
3344	Trans. clutch shift, (wt. 14 oz.)	.59

Transmission Cover and Parts

3362	Trans. cover bolt and nut, (wt. 2 oz.)	5c
3372	Trans. cover felt gasket (front)	3c
3374	Trans. cover door screw	2c
3375	Universal ball cap (rear), (wt. 1 lb.)	.24
3369	Universal ball cap (front), (wt. 2 lbs.)	.72
3371	Universal ball cap screw, (wt. 2 oz.)	3c
3372	Universal ball cap bolt and nut, (2 oz.)	5c
3375	Trans. cover screw, (wt. 2 oz.)	3c
3376B	Trans. cover, starter type, (wt. 15 lbs.)	6.35
See Hudco-Ford Transmission Cover on page 92		
3377	Trans. cover felt gasket (pair), (wt. 2 oz.)	.8c
3378	Trans. cover sloping door, (wt. 8 oz.)	.12
3379	Trans. cover sloping door gasket	4c
3380	Bendix cover, 1919-24, (wt. 8 oz.)	.13
3381	Bendix cover rear plate, 1919-24, (wt. 4 oz.)	3c
3382	Trans. cover gasket, 1919-24, (wt. 4 oz.)	5c
3383	Trans. cover front plate, 1919-24, (wt. 8 oz.)	5c
Transmission Control Parts		
3400	Trans. clutch release ring, (wt. 6 oz.)	.16
3402D	Clutch lever and shaft, 1913 to 23,	.24
3403	Clutch lever bolt and nut, (wt. 2 oz.)	3c
See Special Ball-bearing Bolt on opposite page		
3405	Clutch lever pin	1c
3406B	Clutch release fork—right or left (3 oz.)	.12
3406C	Clutch release fork pin	1c
3411	Clutch lever clevis pin, (wt. 2 oz.)	2c
3413	TRANSMISSION BAND ASSEMBLY, (weight 1 1/4 lbs.)	.45
3415	Trans. band washer	2c
3416	Trans. band lining	See Page 85
3419	Trans. band adjusting screw (wt. 4 oz.)	8c
3420	Trans. band adjusting screw nut, (wt. 2 oz.)	3c
3421B	Trans. band ear iron rivet per doz.	4c
3422B	Trans. band brass rivet	See Page 84
3423B	Trans. band brass rivet, 1/2" x 3/8"	See Page 84
3425	Trans. band spring (wt. 2 oz.)	3c
3426	Trans. band adjusting nut, (wt. 2 oz.)	3c
3427	Slow speed shaft, (wt. 1 lb.)	12

Trans. Control Parts—Cont'd

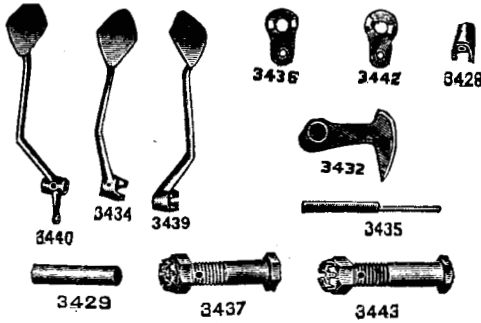

- 3428 Slow speed notch (wt. 8 oz.)..... **19**
- 3429 Slow speed notch pin..... **1c**
- 3432 Speed lever, (wt. 8 oz.)..... **8c**
- 3434 Reverse pedal, (wt. 1 lb.)..... **42**
- 3435 Brake and rev. pedal shaft (wt. 8 oz.)..... **12**
- 3436 Brake and rev. pedal support (wt. 3 oz.)..... **12**
- 3437 Brake and rev. support bolt and nut..... **12**
- 3439 Brake pedal, (wt. 1 lb.)..... **42**
- 3440 Clutch pedal, (wt. 1 lb.)..... **42**
- 3441 Pedal pin..... **2c**
- 3442 Clutch pedal support, (wt. 3 oz.)..... **1c**
- 3443 Clutch pedal support bolt and nut..... **4c**

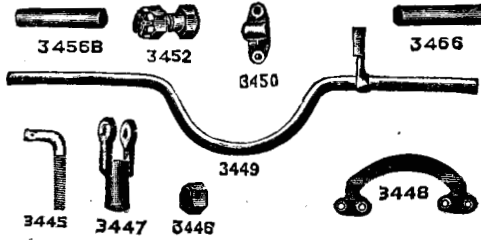

- 3445 Slow speed connection, (wt. 2 oz.)..... **4c**
- 3446 Slow speed con. lock nut..... **2c**
- 3447 Slow speed con. clevis, (wt. 2 oz.)..... **8c**
- 3448 Controller quadrant, (wt. 1 lb.)..... **17**
- 3449 CONT. SHAFT WITH SPEED LEVER (weight 4 lbs.)..... **49**
- 3450 Controller shaft bracket, (wt. 5 oz.)..... **12**
- 3452 Controller shaft bracket bolt and nut..... **4c**

Hub Brake Control

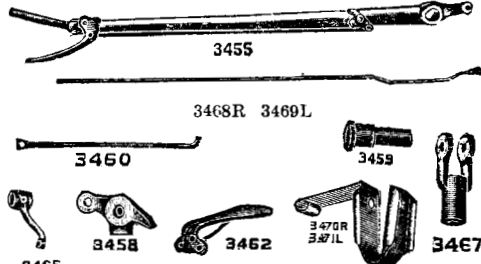

- 3455 Hand brake lever assembly, (wt. 2 lbs.)... **85**
- 3456B Hand brake lever pin..... **2c**
- 3457 Hand brake lever key, (wt. 2 oz.)..... **4c**
- 3458 Hand brake lever pawl, (wt. 2 oz.)..... **5c**
- 3459 Hand brake lever pawl pin..... **1c**
- 3460 Hand brake lever pawl rod..... **9c**
- 3452 Hand brake lever handle & spring assembly..... **9c**
- 3463 Hand brake lever pawl lift spring..... **2c**
- 3465 Hub brake lever on cont. shaft, (wt. 3 oz.)..... **12**
- 3466 Hub brake lever pin..... **1c**
- 3467 Hub brake lever clevis..... **8c**
- 3458 Hub brake pull rod—right, (wt. 2 lbs.)..... **24**
- 3469 Hub brake pull rod—left, (wt. 2 lbs.)..... **24**
- 3470R Hub brake rod support—right, (wt. 2 oz.)..... **7c**
- 3471L Hub brake rod support—left, (wt. 2 oz.)..... **7c**
- 3472 Hub brake rod support bolt and nut... **2c**

Steering Gear Parts

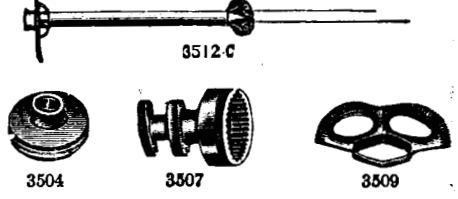

- 3502 Steering gear rim screw..... **1c**
- A5132 17-in. Steering wheel, aluminum spider, Corrugated Walnut rim, (ship. wt. 7 lbs.)... See Page 38
- 3504 Steering gear cover, (wt. 10 oz.)..... **32**
- 3505 Steering gear cover screw..... **1c**
- 3506 Steering gear cover bushing, (wt. 2 oz.)... **9c**
- 3506B Steering gear driv. pinion wash..... **2c**
- 3507 Steering gear internal gear case and bushing, (wt. 2 lbs.)..... **90**
- 3509 Steering gear quadrant, (wt. 7 oz.)..... **9c**
- 3511 Steering gear wheel nut, (wt. 2 oz.)..... **7c**
- 3512C Steering gear tubing assembly, 1912-24, (wt. 8 lbs.)..... **3.60**



- 3513C Steering tubing flange screw and nut..... **3c**
- 3516C Steering gear post, 1912-21, (wt. 7 lbs.)... **1.35**
- 3516D Steering gear post, 1921-24..... **1.58**
- 3517 Steering gear pinions, (wt. 4 oz.), each... **12**
- 3518 Steering gear pinion pin, 1909-24..... **2c**
- 3519 Steering gear drive pinion, (wt. 7 oz.)..... **24**
- 3518B Steering gear pinion pin, long, 1921-24... **2c**
- 3520 Steering gear drive pinion key, (wt. 2 oz.)... **2c**
- 3523 Steering gear post castle nut, (wt. 2 oz.)... **3c**

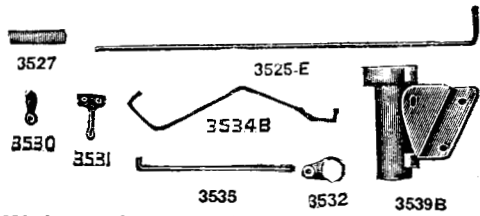

- 3527 Throttle rod, 1912-24, (wt. 1 lb.)..... **27**
- 3525E Lead rod, 1912-24, (wt. 1 1/4 lbs.)..... **27**
- 3527 Lead and throttle rod spring..... **2c**
- 3528 Lead and throttle rod collar..... **2c**
- 3529 Lead and throttle rod pin..... **1c**
- 3530 Lead rod lever, (wt. 2 oz.)..... **7c**
- 3531 Throttle rod lever, (wt. 2 oz.)..... **7c**
- 3532 Throttle rod guide, (wt. 2 oz.)..... **4c**
- 3534B Commutator pull rod, 1912-24..... **8c**
- 3535 Carburetor pull rod, (wt. 3 oz.)..... **8c**

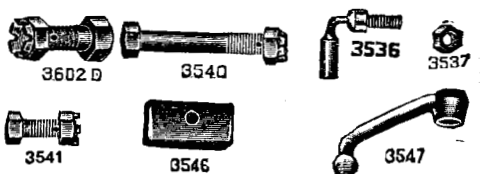

- 3536 Ball and socket joint, with nut 1909-21, **7c**
- 3537 Ball and socket joint nut..... **2c**
- 3539B Steering post bracket with bushings, 1911-24, except ton truck (wt. 8 oz.)... **59**
- 3540 Steering bracket bolt and nut, side, 3/8"x2 1/4" **5c**
- 3541 St. brkt. bolt and nut, top, 1/2" x 1 1/2" **4c**
- 3544 Steering post bracket felt washer..... **2c**
- 3545 Steering post brkt. bushing, pr. (wt. 2 oz.)... **18**
- 3546 Steering post bracket block (wood)..... **7c**
- 3547 Steering gear ball arm, (wt. 12 oz.)..... **32**
- 3548 Steering gear ball arm key, (wt. 2 oz.)..... **3c**

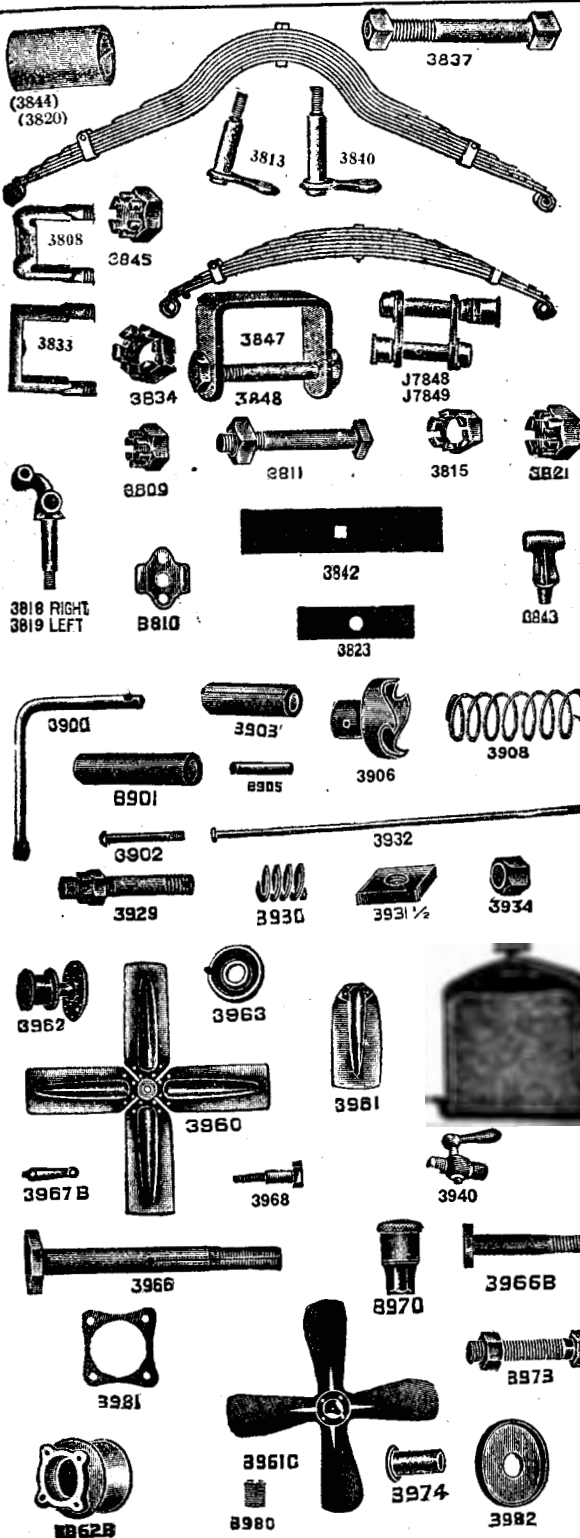

SPRINGS AND PARTS

3800	Front spring, 1909-24, (18 lbs.)	1.48
3808	Front spring clip, 1909-20 (1 lb)	.16
3809	Front spring clip nut, 1909-24	.3c
3810	Front spring clip bar, 1921-24	.19
3811	Front spring tie bolt and nut,	3c
3813	Front spring hanger, 1909-24,	
	(wt. 4 oz.) Each piece.....	.10
J7848	Front spring hanger assembly,	
	See Page 86.	
3815	Front and rear spr. hanger nut	3c
3818	Front spring perch—right, (wt. 15 oz.), 1909-1919.....	.52
3818B	Front spring perch—right, 1919-24 (wt. 15 oz.).....	.39
3819	Front spring perch—left, 1909-19, (wt. 15 oz.).....	.52
3819B	Front Spring perch—left, 1919-24	.39
3820	Front spring perch bushing (2 oz.)	3c
3821	Front spring perch nut, 1909-20	4c
3821B	Front spring perch nut, 1921-24	4c
3823	Front spring leather, (2 oz.)	5c
3824	REAR SPRING, 1909-24, (wt. 47 lbs.).....	4.78
3833	Rear spring clip, 1909-23 (2 oz.)	.18
3834	Rear spring clip nut, 1909-24.	5c
3835	Rear spring clip bar, 1909-24,	5c
3837	Rear spring tie bolt and nut.....	5c
3840	Rear spring hanger, (wt. 5 oz.)	
	Each piece.....	.12
J7849	Rear spring hanger assembly,	
	See Page 86.	
3842	Rear spring leather pad (2 oz.)	5c
3843	Rear spring perch (wt. 12 oz.)	.28
3844	Rear spring bushing, (wt. 2 oz)	3c
3845	Rear spring perch nut.....	4c
3847	Front spring retainer clip, 1909-16, (wt. 2 oz.).....	5c
3847B	Front spring retainer clip, 1916 to 24, (wt. 2 oz.).....	5c
3848	Rear spring retainer clip, 1900-17	5c
3848B	Rear spring retainer clip, 1918-24, (wt. 2 oz.).....	5c
STARTING CRANK		
3900	Starting crank only (wt. 2 lbs.)	.32
3901	Starting crank handle (8 oz)	.14
3902	Starting crank handle bolt (4 oz.)	.6c
3903	Starting crank sleeve (wt. 4 oz.)	.8c
3905	Starting crank ratchet pin.....	.3c
3906	Starting crank ratchet (8 oz.)	.14
3908	Starting crank spring.....	.2c
RADIATOR-THERMO SYPHON		
3925	Radiator, 1909-24.....	See Page 79
3928	Radiator pad, 1909-19, leather	4c
3929	Rad. stud and nut, 1909-19	5c
3929B	Rad. stud and nut, 1919-24	6c
3930	Radiator stud spring.....	3c
3931 1/2	Radiator stud washer nut.....	2c
3932	Radiator rod (wt. 8 oz.).....	.15
3932B	Rad. Rod for steel dash, '23-24	.15
3934	Radiator rod nut.....	.2c
3939	Outlet connection pipe, (12 oz.)	.19
3940	Outlet connection cock (2 oz.)	.12
3975	Rad. spring upper thimble...	.2c
3976	Rad. spring lower thimble...	3c
3977	Radiator apron, 1923-24, (will fit 1917-22 Fords).....	.45c
RADIATOR FAN		
3960	Fan and pulley comp., 1909-20	.70
3960B	Fan and pulley comp. 1920-24..	.75
3961	Fan blade, (1909-20).....	.6c
3961B	Fan blade rivets, doz.....	4c
3961C	Fan blade assembly, 1920-24.	.19
3962	Driven fan pulley, 1909-20.....	.30
3962B	Driven fan pulley, 1920-24.....	.30
3963	Fan drive pulley, 1909-20.....	.16
3963B	Fan drive pulley, 1920-24.....	.16
3966	Fanshaft, 1909-20.....	.16
3966B	Fanshaft, 1920-24.....	.16
3967B	Fan bracket, 1917-24.....	.24
3968	Fan bracket bolt, 1909-24.....	.8c
3970	Fan grease cup, 1909-20.....	.7c
3973	Fan adjusting screw and nut.	3c
3974	Fan driven pulley bushing, 1917-20.....	.12
3974B	Fan driven pulley bushing, 1920-24.....	.12
3980	Fan pulley plug, 1920-24.....	.3c
3981	Fan pulley gasket, 1920-24.....	.2c
3982	Fanshaft cap, 1920-24.....	.2c
3983	Fanshaft flt washer, 1920-24	.2c
3984	Fan blade screw, 1920-24.....	.1c
3988	Fan shaft nut, 1920-24.....	.2c

FENDERS AND HOOD PARTS

Muffler and Parts

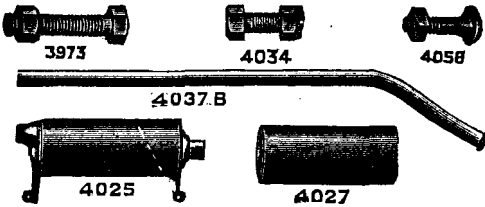

4025	Muffler assembly, 1909-20 (wt. 4 lbs.)	1.10
4025B	Muffler assembly, 1921-24 (includes muffler, long exhaust pipe and nut) (wt. 8 lbs.)	1.95
4026B	Muffler head—front, 1917-20 (wt. 2 lbs.)	.25
4027	Muffler shell—outer 1909-24 (wt. 1 lb.)	.25
4028	Muffler shell—middle (wt. 1 lb.)	.25
4029	Muffler shell—inner 1909-20	.15
4030B	Muffler rod only, 1917-20	.25
4031	Muffler rod nut	.25
4037B	Long exhaust pipe 1909-20 (3 lbs.)	.95
4037C	Long exhaust pipe 1920-24 (4 1/2 lbs.)	.95
4040B	Rear muffler head, 1917-20 (wt. 2 lbs.)	.25
4041	Muffler to frame bolt and nut, 1917-20	.25
4041B	Muffler to frame bolt and nut, 1921-24	.25

Hood and Parts

4050B	Hood, 1917-23, (wt. 8 lbs.)	3.75	
4050C	Hood, 1923-24	3.95	
4052B	Hood clip, 1917-24, (wt. 3 oz.)	4c	
4053B	Hood clip spring 1917-24	2c	
4056B	Hood block, left, 1917-23 (wt. 2 oz.)	.17	
4057B	Hood block, right, 1917-23, (wt. 2 oz.)	.17	
4058C	Hood pad (on dash), 1917-24, (wt. 2 oz.)	.12	
4060D	Hood pad (on radiator shell), 1917-24,	.12	
4061B	Hood clasp (on dash), 1917-23	5c	
4061C	Screw for 4061B	1c	

Fenders and Parts

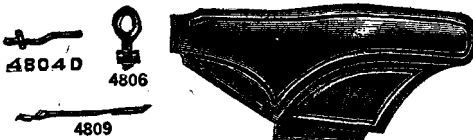

For complete set of fenders see page 39.
When ordering fenders in less than a full set, add 50c to price of each fender for crating. Will not fit 4-door Sedan or 1924 Models.

4800B	Front fender—right, 1917-23	1.00
4801B	Front fender—left, 1917-23	1.00
4802F	Rear fender—right, 1917-23	.75
4803F	Rear fender—left, 1917-23	.75
4804D	Rear fender iron R., or L., 1913-21, Tour.	1.35
4804E	Rear fender iron—right, 1913-24, (wt. 1 1/2 lbs.) Roadster or Coupe	.45
4804F	Rear fender iron—left, 1913-24, (2 lbs.) Roadster and Coupe	.45
4804K	Rear fender iron, Sedan, 1918-24	.14
4804L	Rear fender iron, Touring, 1921-24	.10
4805B	Rear fender iron bolt and nut, 1915-24	.05
4806B	Rear fender eye bolt, nut and washer	.05
4808	Front fender iron bolt & nut (side), 1910-24	.05
4808B	Front fender iron bolt and nut (bottom)	.05
4808C	Front fender apron to frame bolt and nut	.05
4809	Front fender iron—R. or L., 1909-24	.54

Starter and Generator Parts

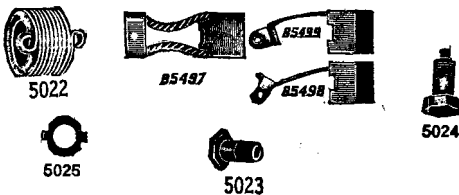

Running Boards and Shields

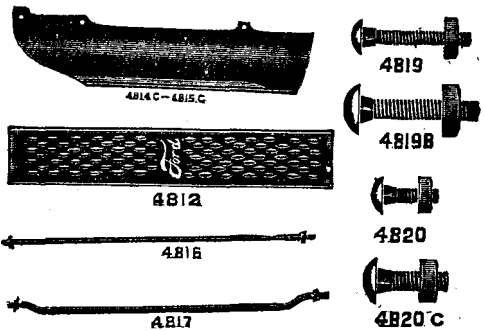

4812	Running board—R. or L., 1909-24, 44 3/4" (wt. 10 lbs.)	1.10
4814C	Running board metal shield—R., 1917-23, except 4 door sedan (wt. 10 lbs.)	1.95
4815C	Running board metal shield—L., 1917-23, except 4 door sedan	1.95
4816	Running board truss rod—front, 1909-21	.29
4817	Running board truss rod—rear, 1909-21	.29
4819	R. B. to rear fender bolt and nut, 1909-20	3c
4819B	R.B. to rear fender bolt and nut, 1921-24	3c
4820	R.B. to front fender bolt and nut, 1909-20	3c
4820C	R.B. to front fender bolt and nut, 1921-24	3c

Body Parts

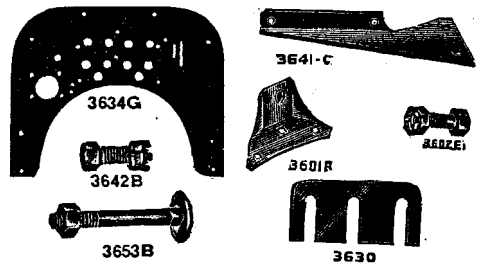

3601B	Body bracket on body, center and rear	8c
3602E	Body bracket con. bolt and nut	5c
3630	Floor board forward plate, (wt. 6 oz.)	8c
3632	Floor board rear plate for pedals (12 oz.)	8c
3633	Floor board plate for side lever, (wt. 5 oz.)	4c
3634G	Dash, (wood), 1917-23, (wt. 10 lbs.)	1.55
3638B	Dash shield, 1919-23, (wt. 4 oz.)	.90
3640C	Dash bracket—left, 1917-23, (wt. 10 oz.)	.13
3641C	Dash bracket—right, 1917-23, (wt. 10 oz.)	.13
3642B	Dash bracket to dash bolt and nut 17-23.	3c
3074	Dash bracket to frame bolt and nut	4c
3653B	Dash to body bracket bolt and nut	4c
3660C	Tail lamp & license bracket assembly—tour. and sedan (wt. 8 oz.)	.22
3660D	Tail lamp bracket, Roadster and Coupe (wt. 8 oz.)	.22
5679X	Door lock, Touring, right rear	.36
5680X	Door lock, right front or left rear	.36
8433X	Striker plate for either lock	9c
7831X	Curtain to windshield hook	2c
9484X	Key for Coupe rear compartment lock	.10

B5497	—Starter Brush. (4 oz.)	.16
B5498	—Generator Brush—Large. (4 oz.)	.12
B5499	—Generator Brush—Small. (2 oz.)	.11
5018	—Bendix only, complete (wt. 2 1/2 oz.)	3.65
5022	—Bendix spring (wt., 8 oz.)	.32
5023	—Bendix spring screw (on shaft)	.30
5024	—Bendix spring screw (on bendix head)	.40
5025	—Lock washer for P5023 or P5024	1c
5056	—Motor mounting gasket	1c
5057	—Generator head gasket	2c
5059	—Bendix cover screw	1c
5062	—Motor mounting screw	2c
5135	—Generator oil cup (wt. 2 oz.)	5c

GENUINE ARMSTRONG CORK GASKETS FOR FORD CARS

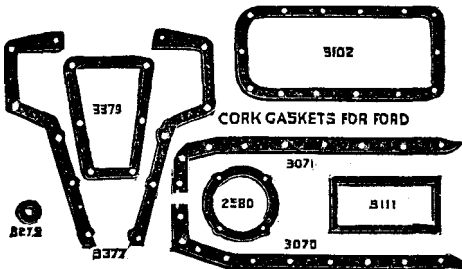

CORK GASKETS FOR FORD

Made of strong pressed cork. Much more durable and oil proof than felt. Will save their cost every few weeks in preventing loss of oil. Keep outside of motor much cleaner by keeping oil in. Made in same size as felt. Sold only in sets of 11 containing one each, 2580, 3070, 3071, 3102, 3279, 3363 long, 3363 short, 3379, and 3111C and two 3377. These Armstrong cork gaskets are full size and guaranteed to fit. They should not be confused with the undersized gaskets of inferior quality offered by others at slightly less prices. **J7737—Complete cork gasket set for Fords..... .35**

Sheet Cork

High quality sheet cork, 1-16 in. thick, for use in making gaskets. Comes in sheets, 12x36 in. **J7725—Cork, per sheet. .35**

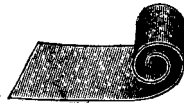

Felt Gasket Sets for Fords 28c

Made of high grade wool felt in the correct sizes and shapes to fit parts shown. Save delay by having a full set of these on hand before you begin a repair job.

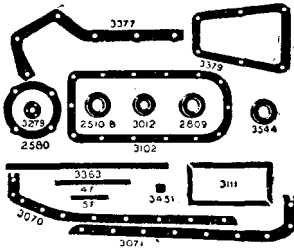

Shipping weight, set, 1 lb. **J7724—Full set 20 gaskets and washers..... .28**

Form-a-Gasket Compound

Used either alone or on top of any kind of old or new gaskets. Makes a union that is pressure-tight, stands very high heat, and is leak-proof to gasoline, grease, oil or water. Saves much time and gasket material. Fine for warped cylinder heads. **J7612—2-oz. handy tube Form-a-Gasket..... .32**



Stick-Tite Gasket Cement



Leaky gaskets and connections are bound to decrease compression, thereby loss of power of your motor.

Gasket Cement makes the gaskets air-tight and a leak-proof connection unaffected by gasoline, oil or heat. Works on all forms of gaskets, asbestos, copper or felt.

J7742—2 oz. bottle, with dauber cork14
J7741—1 pint can. (Ship. wt., 2 lbs.)..... .48

3 in 1 Exhaust and Intake Gasket



only two on a motor in place of six. Very easy to hold in place while setting manifolds. Made of copper sheets with asbestos between. Two required for the car.

J7736—Each (Ship. wt., 2 oz.)..... .10

Copper Gaskets for Ford Cars

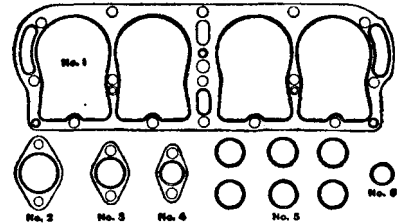

1. Cylinder Head Gasket.
2. Cylinder Head Outlet Gasket.
3. Cylinder Head Inlet Gasket.
4. Carburetor Flange Gasket.
5. Inlet and Exhaust Pipe Gasket.
6. Transmission Drain Plug Gasket.

Extra quality, well made of copper and brass, lined with best asbestos. Complete set consists of one cylinder head gasket, one cylinder head outlet gasket, one cylinder water inlet gasket, one carburetor flange gasket, six inlet and exhaust pipe gaskets. Every Ford owner should get a full set of all copper gaskets used on the car (also felt gaskets) before starting to overhaul car. Shipping weight, per set, 1 lb. **J7727—Full Set 11 Gaskets, for Ford car..... .346**
J7734—Cyl.-Head Gasket for Ford car. Ship.wt. 12 oz. .246
J7728—Set 10 small gaskets less cylinder head gasket .15

Axle Packing Washers

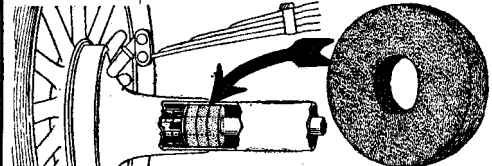

An extra large heavy felt washer for rear axle, which will prevent grease from working out. About 3-inch diameter by 1/4 inches thick. When compressed to go into axle housing they hug the axle shaft very tight so no grease can get by. To install these washers the outer roller bearing is slipped out, washers pushed in and bearing replaced. One, two or three washers can be used on each side. It is best to get a full set of six. Ship. wt., each, 2 oz. **J7760—Each..... 6c** Set of 6..... **.29**

Felt Washers for Axle and Hub

Made to fit rear axle and front hubs. Grease should not be allowed to work out at the hubs and be thrown on the tires, as it is not good for the rubber, also very unsightly. This set contains six felt washers, assorted sizes as required on Ford cars. 2 No. 2510B, 2 No. 2809, 1 No. 3012 and 1 No. 3544. **J7755—Set 6 Washers. (Ship. wt., 4 oz.) .12**



Felt Washers for Ford 1-ton Truck

Extra quality felt grease retainers and washers to fit the Ford One Ton Truck. K8235 and K8236 are to replace the washers on the Ford Truck. K8234 is heavy thick felt and is to be used in the same manner as the axle packing washer shown above and will pay for itself many times over in grease saved. Shipping weight, 4 oz. each. **K8234—Heavy grease retainer washer, each..... .18**
K8235—Rear axle bearing felt washer (to replace Ford No. 1021), each..... .8c
K8236—Rear hub felt washer (to replace Ford No. 1118), each..... .5c



Combination Gasket and Gland

For Ford Manifolds

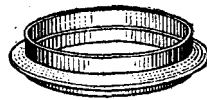

A special "two-in-one" washer, which takes the place of both Nos. 3063 and 3064 gasket and gland for Ford exhaust pipe and inlet pipe. Much easier to put in than regular ones. Shipping weight, 1 oz. **J7729—Each, 4c, set of 6..... .22**

**White Stripe Cord Fan Belts
FOR FORD CARS**

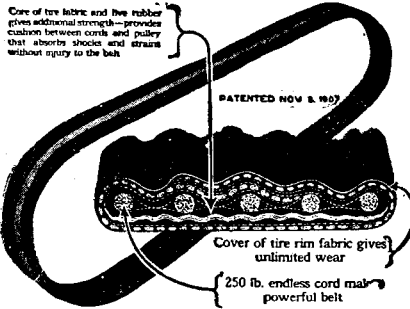

48c

This belt is made of highest quality, genuine cord tire fabric, and not the cheap hose fabric from which many so-called cord belts are made. In addition to this, it has, as a special feature, five endless cords, which are actually built into the belt. This gives it the ability to "give" under stress and then come back to its normal position. It is this flexibility which makes it outwear from five to ten of the ordinary fabric or cord fan belts. Costs more at first, but is by far the cheapest belt in the long run. Absolutely guaranteed to give satisfactory service or we will refund your money. Shipping weight, 8 oz.

- B5327—For 1917-19 Fords **.48**
- B5328—For 1920-24 Fords (with new style fan) **.48**

**Extra Quality Leather Fan Belts
FOR FORD CARS AND FORDSON**

ONLY
22c



These belts are made of the highest quality Oak Tan Leather Belting, and are equal in quality to belts which others retail at 50c or more. This is the endless type, with splice securely stitched and cemented, guaranteed not to open up. Shipping weight, 8 oz.

- B5330—Endless, for 1916 or older Fords **.22**
- B5331—Endless, for 1917-20 Fords **.22**
- B5332—Endless, for 1920-24 Fords **.22**
- K8120—For Fordson Tractor **1.19**

**Old Hickory Fan Belts
FOR FORD CARS**



Made of heavy cotton fabric, treated to prevent slipping and to protect it from the oil and heat. It is woven by a special process, which prevents it from coming apart and allows it to wear down to the last layer of fabric. Used as standard equipment on a number of tractors and trucks, on which a belt is subjected to very hard wear and excessive heat and oil. Guaranteed satisfactory or your money will be refunded. Shipping weight, 8 oz.

- B5348—For 1917 to 1919 Ford cars **.24**
- B5349—For 1920 to 1924 Ford cars **.24**

Gasoline Siphon

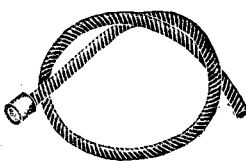

Made of 3/8" flexible steel gas tubing, 2 feet long. Lets you drain gasoline from any gas tank without crawling under car. Makes it easy to get gasoline from passing car if you run out on the road.
A5180—Each (ship. wt., 12 oz.) **.22**

**"Western" Cord Fan Belts
FOR POPULAR CARS**



A good fan belt is an absolute necessity. It is subjected to constant oil and water soaking and sizzling heat from the motor, the dust and dirt from the road, as well as the strain and friction of regular use. That is why experienced car owners generally insist on getting the best belt that they can possibly find, regardless of price.

Our "Western" Cord fan belt is made to stand up under hard service. As shown in the illustration, it is made of five plies of strong fabric (same quality as is used in the best grade tires), scientifically treated to make them oil-, heat- and water-proof, then put together and carefully vulcanized into a solid, endless belt. Guaranteed to give satisfactory service.

In ordering, be sure to give year and model of car. Average shipping weight, 12 oz.

- B5338—For 1916 or older Fords **.16**
- B5339—For 1917 to 1920 Fords **.19**
- B5340—1921-24 Model Fords **.20**
- K8120—Fordson Tractor **1.19**
- B5530—Fits Overland 1917-19, 83B, 85B, 90B, all 4s; Studebaker 1920-21, Big and Special "6", 3/8 in. belt **.45**
- B5512—Fits Studebaker Light Six **.42**
- B5531—Fits Elgin "6," 1919-21; Nash 1917-18, 2017-18, 3017-18; Overland 1915-19, 80, 81, 83; 91, 1922-23 Paige 1919-22, 15-6-42; Stearns Knight, 1920-21, SKL4 and 1923-6 **.45**
- B5532—Fits Chevrolet 490 and FA, 1916-17 **.29**
- B5533—Fits Briscoe 1916-19, B-4,24; Dort 1915-21, 15-17A; Elgin "6," 1916-18; Grant 1915-17 **.37**
- B5534—Fits Buick 1918-20, E, H & K, 44-50 **.45**
- B5539—Fits Allen 1915-18; Buick 1915-17, C24, 25, 36, 37, 54, 55, D37, 54, 55; Dodge 1917-22; Dort 1921-22; Gardner 1920-22; Overland 1916-19, 75-75B-90-90CC; Velie 1922-24 **.45**
- B5536—Fits Dodge 1915-16; Velie "6," 1915-18 **.42**
- B5537—Fits Buick 1916-17, D34-35, 44 to 47; Buick 1918, E34, 35, 44 to 50 Early Type **.42**
- B5541—Fits Chalmers 1916-24, Gardner 1923-24, Columbia 1919-22, Grant 1918-20 **.65**
- B5510—Fits Willys-Knight 1920-22, Hudson 1920-24 **.45**
- B5511—Fits Elgin, 1922-23, K 1; Lexington, 1917-19; Paige, 1916-18, 6-46-51-55; Reo, all 4s; Saxon "6," 1916-20 **.45**
- B5529—Fits Essex "19"-23; Willys-Knight, "23"-24 **.52**
- B5528—Fits Allen Series 43, 1919-22; Buick 1921-23, 44 to 50; Buick 4, 1922-23; King, 1919-23 **.45**
- B5538—Fits Maxwell 25, 1916-17; Dort 6, "23"-24 **.88**
- B5542—Fits Maxwell 25, 1918-20, below 271, 591 **.98**
- B5543—Fits Maxwell 25, 1920-21, 271591 and over **.98**

"V" Fan Belts

- B5544—Fits Chevrolet 490 and Superior, 1918-24, FA, 1917-18 **.78**
- B5544—Fits Chevrolet FB, 1919-22; Stephens, 1922-24 **.98**
- B5546—Fits Hupmobile, 1920-22, R **.78**
- B5547—Fits Oakland, 1916-23; Oldsmobile, 17-21 **.85**
- B5505—Fits Nash 6, 1918-22; Nash 4, 1921-22 **1.39**
- B5506—Fits Maxwell, 1922-24 **1.39**
- B5507—Fits Durant 4, 1922-24 **1.39**
- B5508—Fits Durant 6, '20-'23; Marmon, '20-'23 **1.39**

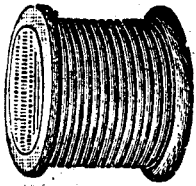

Round Belting.

Made of very firm, solid leather which wears well. Shipping wt., per ft., 4 oz.

- B5552—5-16" size, per ft. **.11**
- B5553—¾" size, per ft. **.15**

Made in sections, bolted and riveted together. Cut to any length and furnished with bolts and nuts for making endless. Shipping wt., per ft., 1 lb.

Laminated V-Belting.

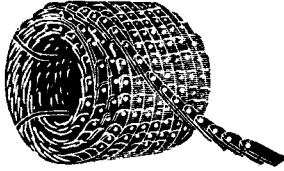

- B5556—5/8" wide at top, per ft. **.24**
- B5557—¾" wide at top, per ft. **.28**

Flat Belting

High grade oak tan belting for auto fans. Very durable, does not stretch easily. Shipping weight, per ft., 8 oz.

- B5548—¾" wide, per ft. **.10**
- B5549—¾" wide, per ft. **.12**
- B5550—1" wide, per ft. **.14**
- B5551—1¼" wide, per ft. **.16**

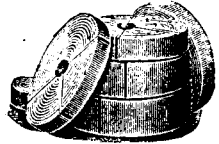

V-Leather Belting.

Made from two layers of very strong lasting leather, cemented together and cut in V-shape as shown. Shipping wt., per ft., 8 oz.

- B5554—5/8" wide at top, per ft. **.26**
- B5555—¾" wide at top, per ft. **.28**



Round Leather Belt Hooks

B5559—Wire Hooks for Round Leather Belting. Dozen. (Ship. wt., 2 oz.) . . . **.10**

Flat Belt Coupling

Detachable belt hooks are very convenient and make a permanent coupling. Ship. wt., each, 4 oz.

- B5558—Coupling with Rivets for ¾" and 1" belting, set . . . **.10**
- B5558A—Coupling with Rivets for 1" and 1¼" belting, set . . . **.10**

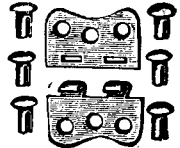

Copper Wire

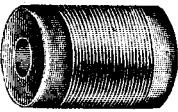

Small spool 20 gauge copper wire. Very handy for wrapping broken parts or running through end of bolts to prevent nuts loosening. Ship. wt., 4 oz.

- J7621—Each. **9c**

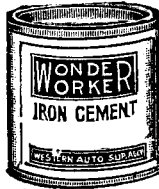

Cast Steel and Iron Cement

A metallic chemical iron cement that withstands heat, oils, grease and steam. When once hard it becomes a metallic surface which contracts or expands like iron. Used extensively in repairing cracks, blow holes, defective cylinders, jackets, radiators, etc. Shipping weight, 10 oz.

- J7752—Per Can. **.24**

Stove Pipe Wire

Has a thousand uses around the car and the garage. Especially fine for threading the heads of stud bolts to keep them from working loose. Black enameled to prevent rust. Ship. wt., 8 oz.

- J7630—¼-lb. roll, 19 gauge, ea. . . . **9c**

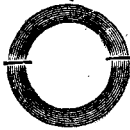

Engine Shim Assortment for Ford

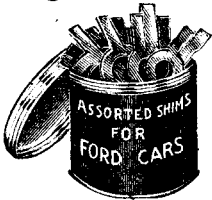

High-quality shims, specially cut of proper varied thicknesses to obtain the correct adjustment on Ford crank-shaft and connecting rod bearings. Each can contains 100 assorted shims; you should have one on hand when you start to overhaul your motor.

- J7638—Complete in handy can (ship. wt., 12 oz.) . . . **.68**

Brass Shim Stock

For use when it is necessary to cut out shims for repairs. The package contains six sheets of special sheet brass, each 8x2½ inches, with thicknesses of .001, .002, .0035, .005, .007, and .010. Shipping weight, 8 oz.

- J7635—Shim Stock, assortment. **.29**



Laminated Shims for Ford



Made of laminum, the only metal made in layers of .002 inch, so they can be peeled off as desired, yet as solid as a single piece. Our shim sets contain full assortment of 14, for connecting rod and crank shaft bearings.

- J7641—Connecting Rod Shim, each **.06**
- J 642—Front or center main bearing shim, each . . . **.05**
- J7643—Rear main bearing shim, each **.08**
- J7640—Full Set of 14 (weight, 4 oz.) **.68**

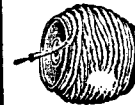

Asbestos Yarn

Pure asbestos yarn put up in spools containing about 40 feet.

Used especially for packing spark plug porcelains. Ship. wt., 2 oz.

- J7627—Per Spool **.19**

Asbestos Wick Packing

Selected asbestos fiber, spun into strands; can be separated and made into any form or shape for packing small valve stems, etc. Will stand any temperature or pressure, making it particularly good for packing exhaust and water pipes. Ship. wt., 8 oz.



- J7628—¼-lb. Ball. **.29**
- J7626—¼-lb. spool Graphited Packing, ¼ inch in diameter, for water pumps, etc. **.39**

Screw Driver Bits



Forged from high grade steel;

- shanks well shaped to fit any standard brace. Carefully tempered and well finished. A high-grade tool throughout. Ship. wt., 4 oz.
- J7890—4 inch size. **.19**
- J7891—5 inch size. **.28**

Automatic Blow Torch

No Pumping No Priming No Blowing



A non-leakable blow torch that is absolutely automatic. Simply see that there is a supply of denatured alcohol in the torch, remove the cap, and light with a match. The heat (generates 1400° in 10 seconds) provides sufficient force to shoot the flame direct to the point desired. Practical for all soldering jobs. Can be worked at any angle. Simply and strongly constructed, will last for years. 5½ inches tall. Shipping weight, 1 lb. Regular price, \$1.50.

H7515—Our Reduced Price..... 1.18

Blow Torch

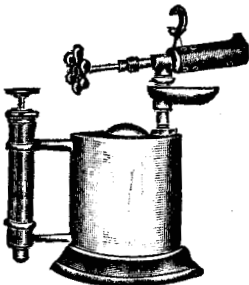

A high-grade, quality brass torch. Built for medium and ordinary work. Pump is built in the handle. Is especially strong and simple in construction. Cast brass knob and cap. Has hook and support for soldering irons. Burner made of special patented material, giving an excellent flame. Every car owner should own a good blow torch. It will soon pay for itself in the saving on repair bills. Capacity, 1 quart. Shipping wt., 3 lbs

H7575—Our Reduced Price, each... 4.65

Neu-Metal Solder



Solder Without Heat or Acid.

Neu-Metal Solder will instantly air-harden even in boiling hot water. It cannot be melted. No heat or acids required in using—useful in mending radiators, water pipes, gasoline tanks and all kinds of metal, brass, tin, etc. Also very handy and useful about the home.

H7510—Each, (shipping weight, 8 oz.)..... .22

“Solderall”

The Handiest Solder Ever Invented

A pure tin solder combined with non-corrosive flux in paste form all ready for instant use.



Solderallis a necessity in the kit of every automobile. For joining wires, stopping leaks, or repairing breaks of any metal parts, it is indispensable.

It will mend anything in metal; it is put up in best and handiest form. All you need to do is to squeeze a little from the tube on the parts to be mended, then heat with a match, torch or soldering iron and a perfect job is the result. “It’s Always Handy.”

H7507—Each (shipping weight, ½ lb.)... .22

Bar Solder

High grade solder for general repair purposes. Ship. wt. 1 lb.



H7504— ½-lb. Bar. .22

“Acid-Core” Wire Solder
A Self-Fluxing Wire Solder



The solder is a hollow wire filled with an acid soldering flux. No other flux or acid is required. The solder is made from Strait’s tin and St. Joe lead, both absolutely pure metals. The solder tube is a series of cells. As one cell is separated from the others, no excess flux can flow from the remaining cells. Cheap



er to use than solid wire or bar solder. There is no loss of time in preparing the flux, hunting for the flux, or applying the flux, as the solder and flux are together and ready to use.

The most practical solder for automobile work. Cleaner and quicker results, with no waste. Just the thing for repairing radiator leaks, spark plug terminals, gasoline pipes, battery terminals, cracked fenders, speedometer shafts and general work.

Our Reduced Price
H7503—½ lb. coil..... .22
H7501—1-lb. spool..... .39

Wire Solder



Very fine quality wire solder. For general use. Works fine.

H7499—½ lb. roll..... .22
H7500—1 lb. roll..... .39

The Metallurgical Marvel

Reparall Metal



Cracks in auto parts, such as cylinder heads, crank cases, radiators, etc., which formerly had to be repaired by brazing or welding, can now be repaired by anyone in a few minutes with Reparall Metal. To use, simply heat the crack with a small torch to 250° (only a little above the boiling point of water), then rub a stick of Reparall Metal into the crack, where it fluxuates perfectly and practically becomes a part of the metal. The repair will then withstand 600° heat (much hotter than an automobile ever gets) and 1200 lbs. pressure, which is more than ample. No acids or salts necessary; so simple that anyone can use it. Articles can be mended from the bottom or sides, as well as from the top, because the heat will draw the

Reparall Metal right into the crack. Endorsed and used by the U. S. Government Aviation Repair Department on Airplane Motors. Fine for repairing almost any sort of household utensils. Absolutely guaranteed. Regular price, \$1.00. (Ship. wt. 8 oz.)
K8149—Our Reduced Price per package..... .59

Soldering Paste

Non-Corrosive.



Soldering Paste is quite effective and acts very quickly. It is semi-solid, easy to apply and will reach difficult, out-of-way places.

Prepared especially for use by the automobile, motorcycle and motorboat manufacturers and repairers.

Ensures a strong, secure joint. Shipping wt., 8 oz.

H7513—Per ¼-lb. cans... .19

Soldering Iron



A general purpose soldering iron. Can be used for all regular soldering. Very handy around garage and house.

H7497—Soldering Iron, ¼ lb. Each Iron..... .17
H7496—Soldering Iron, ½ lb. Each Iron..... .26
H7498—Wood Handle for soldering iron (wt. 4 oz.)..... .89

You will save a lot of time and prevent annoyance and inconvenience if you will include a box of each of the following in your tool box when motoring. They are made of highest grade material.



Cotter Pins

Box of about 100 cotter pins, various sizes, assorted to meet the demands of auto use. Ship. wt., 8 oz.

J7603—Box... .10

Genuine Campbell Cotter Pins

The improved Campbell self-spreading, pointed-end cotter pins. Lock themselves in place by merely inserting and driving on head until the points are even. Assortment averages 100 cotters, twelve sizes, in handy metal screw-top box, that will not break open and scatter in your toolbox.

J7600—Per box (shipping weight, 8 oz.)... .17



Lock Washers



Assortment of about 40, including practically all the sizes in common use on automobiles. Shipping wt., 4 oz.

J7606—Box... .12

"Never-Slip" Lock Washers

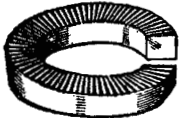

These are heavy lock washers, with $\frac{3}{8}$ -inch hole, made with corrugated surfaces on both sides, so nuts cannot work loose. Especially valuable in replacing engine base and transmission cover bolts on Ford cars, where it is difficult to put cotters back in.

J7608—Package of 2 dozen washers (ship. wt., 4 oz.)... .10

Set Screws

Standard U. S. thread, used in various places on many different kinds of machinery. Assortment contains 14.

Shipping wt., 8 oz. J7618—Box... .28

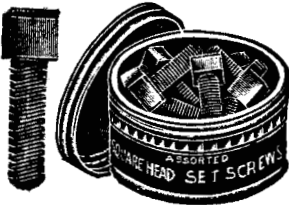

Electric Soldering Iron

Simply screw the plug into the socket of any 110-120-volt electric lighting system (D. C. or A. C.), and the iron heats immediately to the proper heat for soldering, remaining at an even temperature until disconnected. No overheating. A great convenience for quick work and small jobs, as well as a great time-saver for the mechanic, who can work uninterruptedly without having to stop to heat his iron. Complete with 6 feet of asbestos-covered cord, also soldering paste and solder. Fully guaranteed.

H7414—Complete (shipping weight, 1 lb.)... .1.98

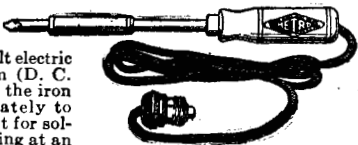

Cotter Pin Extractor

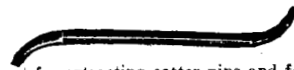

This is used for extracting cotter pins and for spreading the split ends to prevent them from coming out. Made of $\frac{1}{4}$ -inch square steel, pointed on one end and flattened like screwdriver on other end.

H7535—Each (Shipping weight 4 oz.)... .10

Stove Bolts

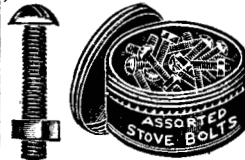

A handy assortment of round head stove bolts for general use. Stove bolts have many uses and this assortment should be in every tool kit. Contains 30 stove bolts from $\frac{1}{2}$ " x $\frac{1}{4}$ " to $1\frac{1}{2}$ " x $\frac{1}{4}$ ". Ship. wt., 8 oz.

J7629—Per can... .24

Cap Screws

Assortment of 12 of sizes most needed in repairing motor cars. Made of good steel. S. A. E. thread. Ship. wt., 8 oz.

J7616—Box... .32



Castellated Nuts



Very frequently needed on all cars. Made of hardened steel and well finished. Assortment of 15. S. A. E. thread. Sizes 5-16" to $\frac{3}{8}$ ". Weight, 8 oz.

J7610—Box... .29

Plain Hex. Nuts

Standard S. A. E. thread nuts made of high-grade material. Very handy to have in your tool box. Assortment of 15. Ship. wt., 8 oz.

J7624—Box... .29



Nickel-plated Wood Screws

Useful in many ways about the car—for attaching step-plates, dash-lights, etc. Furnished in round or oval head, as illustrated. Ship. wt., doz., 2 oz.

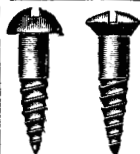

Round Head	Per Doz.	Oval Head	Per Doz.
H7544— $\frac{1}{4}$ ", No. 4.	10	H7551— $\frac{1}{2}$ ", No. 4.	10
H7545— $\frac{3}{8}$ ", No. 5.	10	H7552— $\frac{3}{8}$ ", No. 6.	10
H7546— $\frac{1}{2}$ ", No. 6.	10	H7553— $\frac{1}{2}$ ", No. 7.	10
H7547— $\frac{3}{4}$ ", No. 7.	10	H7554— $\frac{3}{4}$ ", No. 8.	10

Justrite Soldering Iron and Blow Torch

A Great Time-Saver



Burns gasoline and heats itself so that the soldering iron is always hot and does not have to be carried back and forth to the heat, as is the case with the regular style iron. Handle made of special fiber that does not get hot when in use. This is a tool for everyone—mechanics, tinsmiths, plumbers, electricians, auto-owners, and home-owners. Saves you money on your repair bills. Easy to operate. Simply fill tube with gasoline—prime as you would an ordinary torch—and it is ready for use. To use as blow torch, take off soldering iron end, and torch is ready to use. Fine for radio work. Complete instructions furnished. Absolutely safe. Shipping weight, 1 lb.

H7417—Complete with sal ammoniac and solder... .2.28

REMOVE THE CARBON

STOP THE KNOCKING--INCREASE POWER

Johnson's Carbon Remover

Will Clean the Cylinders Without Laying Up Your Car



Johnson's Carbon Remover gives your motor the power of newness—better combustion—quicker pick up—extra strength for heavy pulls. Carbonized valves will soon seat properly and all the knocks caused by carbon deposit will be eliminated. Although very strong and rapid in action, it is harmless and guaranteed not to injure any part of the motor.

The saving in gasoline alone will offset the cost of Johnson's Carbon Remover, to say nothing of repair bills avoided. Just put a few drops in the spark plug holes—no scraping—pulverized refuse blown out through the exhaust. Old methods of scraping and burning, causing hours of delay, have

been given up by big garages and taxicab companies for the Johnson Way.

Our Reduced Price

- G6940— $\frac{1}{2}$ -pint. Can, (Ship. wt., 1 lb.)..... **.58**
- G6939—1-pint. Can, (Ship. wt., 2 lbs.)..... **.95**
- G6938—1-quart. Can, (Ship. wt. 3 lbs.)..... **1.59**

"Gets-It" Carbon Remover and Engine Tonic

This is not only a sure carbon remover, but is also an "Engine Tonic." It is a scientific preparation to be put into the cylinders the same as an ordinary carbon remover. It not only removes all carbon, but loosens all rust, grit and other accumulations from the cylinders, pistons, rings and spark plugs, and acts as a tonic or lubricant, giving the motor increased compression and power. It keeps interior of motor in perfect condition, saves expense of overhauling and lengthens the life of the motor. Guaranteed to contain nothing injurious to any motor.



- G6933—Pint Can (Ship. wt., 2 lbs.)..... **.54**
- G6932—1-quart. Can (Ship. wt., 3 lbs.)..... **.88**

Steel Scratch Brush



Has stiff wire bristles. A handy tool for cleaning pistons and cylinder head of gum and small particles of carbon after caked carbon has been removed. Also brush is handy for roughening tube patches and preparing tube for a patch. H7550—Each, (Shipping weight, 8 oz.)..... **1.9**

Engine Cleaning Brush



A very handy long-handle brush to use around motor chains, gears and other parts where a wire brush is needed. Has wood handle and wire bristles. Will last a long time. Shipping weight, 8 oz. H7542—Each..... **.26**

Bearing Blue

Used to show high spots and uneven surfaces when scraping bearings. Ship. wt. 4 oz. H7455—2-oz. Tube..... **Our Reduced Price .15**



Worko Carbon Remover Tablets



Here is the most wonderful means of removing carbon ever devised. Simply remove the spark plugs put two Worko Tablets in each cylinder, replace the plugs, run the motor slowly for a few minutes and the carbon is gone and your car is ready to use. Contains no injurious acid or chemical, does not interfere with lubrication and is absolutely harmless to everything but carbon. Also cleans valves, pistons, spark plugs and exhaust passage. Get a can now and save big repair bills, as nothing is quite so injurious to a motor car as carbon.

G7007—Box of 24 tablets, (Ship. wt., 8 oz.)..... **.70**

Carbon Cylinder Scrapers

Set of three pieces, different curves to scrape loose carbon through spark plug holes without removing cylinder head. Shipping weight, 1 lb. H7447—Set of three..... **.37**

Scraper Knife

A very handy tool for scraping carbon off top of pistons or out of cylinder head when it is removed, also good for many other purposes. Spring steel blade about 1x3", wood handle. Ship wt., 8 oz. H7436—Scraper Knife..... **.12**

Three-Cornered Bearing Scrapers



Best grade steel, properly tempered. Polished hardwood handle with nickel-plated ferrule. A very handy tool and sure to give good results. **Our Reduced Price** H7450—Each (Ship. wt. 4 oz.)..... **.25**

Set of Three Bearing Scrapers

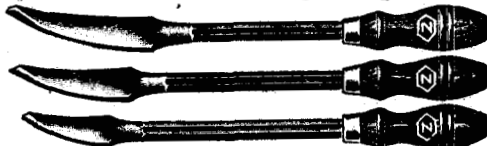

These scrapers are well made of forged steel with ground edges and hardwood handles. Come three sizes in set, properly curved. Shipping weight, 1 $\frac{1}{2}$ lbs. H7453—Our Reduced Price, set of 3..... **.95**

Kwik-Ak-Shun Bearing Compound

Here is a wonderful new invention that will save you hours of time in tightening up your old bearings or putting in new ones. By using Kwik-Ak-Shun you do not have to scrape your bearings at all and you get a much more perfect fit than by the old scraping method. Furnished complete with directions for use. Will grind babbitt, bronze, brass, and all types of soft metal bearings. Will save its cost in one job. Ship. wt., 8 oz. H7457—4 oz. can..... **Our Reduced Price .78**



enuine Williams Tappet Wrenches



Valve tappet wrenches of the highest quality, made of drop-forged steel, finely finished. Thin enough to reach the tappets easily, but sufficiently strong to meet all requirements. Set contains two wrenches each of three different sizes, openings $\frac{1}{8}$ " and $\frac{1}{2}$ " and $\frac{1}{8}$ " and $\frac{3}{8}$ " and $\frac{1}{2}$ " and $\frac{3}{4}$ " and $\frac{1}{2}$ ", this range being desirable for almost any size of valve tappet. Set comes complete in heavy canvas roll, shipping weight 2 lbs.

- 7844—Single wrench, $\frac{1}{8}$ " and $\frac{1}{2}$ " openings **32**
- 7845—Single wrench, $\frac{1}{8}$ " and $\frac{3}{8}$ " openings **39**
- 7846—Single wrench, $\frac{3}{8}$ " and $\frac{1}{2}$ " openings **46**
- 7843—Set of six wrenches, in roll **2.45**

Pressed Steel Tappet Wrench Set

An inexpensive wrench set, suitable for general use in adjusting valve tappets and other light work. Consists of six double-end wrenches, two of each size, complete in canvas case. Sizes are $\frac{1}{8}$ " and $\frac{3}{8}$ ", $\frac{1}{2}$ " and $\frac{3}{8}$ ", $\frac{3}{4}$ " and $\frac{1}{2}$ ". Made of special heat-treated steel; will give good service. Shipping weight, complete set $1\frac{1}{2}$ lbs.

- 7579—Our Reduced Price **.59**



Valve Stem Packings FOR FORD CARS

When the valve guides on an engine wear it is impossible to get a perfect mixture, as air is drawn through the space between the valve stems and the wall of the guides. This results in a skip that is impossible to find, especially at low engine speeds and full power cannot be obtained from the engine, as part of the suction stroke is wasted by drawing air by the valve stems. These packings consist of a special steel stamping and felt washer which is held in position by valve spring as shown in cut. When in position the felt both prevents air from entering the cylinders and also lubricates the valve stem, preventing further wear. They are necessary on the new cars as well as old, and the installation in either case is a matter of a very few minutes. Shipping weight, per set, 4 oz.

- H7418—Per Set of 8, complete **.39**

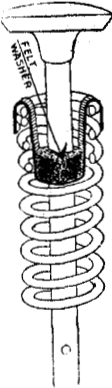

Valve Reamer Guide FOR FORD CARS

There is considerable wear on a Ford car between the valve stems and the walls of the motor block. As a result, air is drawn into the chambers along with the gasoline mixture, and there is loss of compression and of power.

To overcome this trouble, oversize valves are installed, but since this means reaming out the holes to fit, the job is usually turned over to a repair shop, which means a large bill.

Here is an outfit that will let the car owner do the job himself as well as any mechanic. Consists of high-grade valve stem reamer, $\frac{1}{4}$ " oversize, together with a reamer guide, which fastens in one of the cylinder head bolt holes. Insures an accurate job, and valves that seat properly. Impossible to ream out of line. High quality tool steel, guaranteed accurate. Shipping weight, 2 lbs.

- X8751—Complete set, reamer and guide **1.98**
- H7376—Reamer only, for $\frac{1}{4}$ " oversize stem **1.89**
- J8782—Guide only, for valve stem reamer **83**

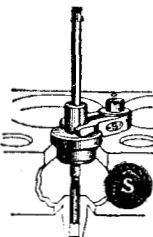

Super-Quality Steel Valves

FOR POPULAR CARS

These are extra quality engine valves, designed to meet the long-felt need of automotive engineers and mechanics for a better quality valve, which would embody all the advantages of valves hitherto used, and overcome their disadvantages.

They will continue to function efficiently, under intense heat conditions, even after thousands of miles of service, and will maintain a perfect seat without warping or pitting under continuous pounding and intense heat.

They will save their slight additional cost many times over, not only in fuel economy, but also because they do not have to be ground so often. Installed the same as regular valves. Shipping weight, each, 4 oz.

- K8040—Regular size for Ford, each **1.50**
- Regular size for Ford, set of 8 **12.00**
- K8041—1-64 over-size for Ford, each **1.60**
- 1-64 over-size for Ford, set of 8 **12.80**
- K8144—Regular size for Dodge, each **1.40**
- K8145—Reg. size for Chev. 490, each **1.40**
- K8146—Regular size for Maxwell, ea. **1.65**

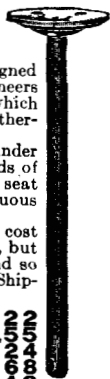

Valve Stem Adjusters FOR FORD CARS



Ford valve stems are not equipped with any adjusting device to take up the wear. After the car has been run a few thousand miles the ends of the valve stems and push rods become worn so the valves are not timed properly; do not open soon enough and close too soon; also don't open wide enough; hence quite a loss of power is the result. Our special Ford Valve Stem Adjusters, with a supply of thin steel discs, will remedy this trouble.

Full set consists of eight adjusters, with a supply of steel discs to take up wear as needed. Ship. wt., 4 oz. H7412—Set of 8, complete **.14**

Thickness Gauge with Handle

A high-quality gauge for spacing valve tappets, etc. Has nine steel leaves, marked by thousandths, as follows: .0015, .002, .003, .004, .006, .008, .010, .012, .015, and a great variety of combinations can be made up by using different leaves together. Has substantial steel handle, which protects the leaves when they are folded together. Ship. wt., 12 oz.



- J8789—Our Reduced Price **.89**

Thickness Gauge

For setting up valve tappets, spacing spark plugs and magneto points. Has 8 leaves, viz.: .002, .003, .004, .005, .006, .007, .008, .032. Made of high quality brass. Leaves have the thickness marked upon them. Ship. wt., 8 oz.

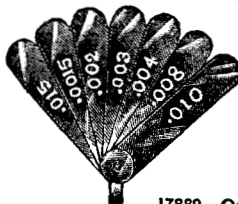

- J8789—Our Reduced Price **.38**

Regular Grade Valves FOR FORD CARS

Same quality engine valves as standard equipment of Ford cars. Furnished in regular standard size, also with 1-64" over-size stem, for use when motor block is worn around the valve stem.

- P3052—Standard size, each **10**
 - P3052B—1-64" oversize, each **10**
 - P3054—Valve springs, extra quality, enameled, each **3c**
- If your valve springs are weak, new ones will improve the running of motor.



Genuine Sioux Valve Grinder

A New Valve Grinder Designed for Rapid Work on any Car.

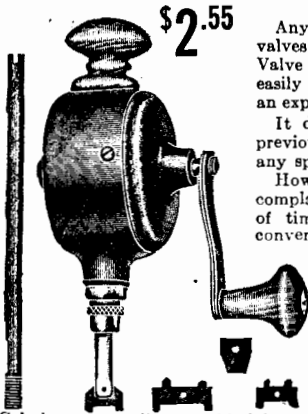

\$2.55

Anyone can grind valves with a "Sioux" Valve Grinder, just as easily and efficiently as an expert.

It does not require previous experience, nor any special knowledge.

How often have you complained of the loss of time awaiting the convenience of the repair man, to say nothing of the expense necessary to grind the valves of your motor.

With the "Sioux" Valve

Grinder you can eliminate this delay, expense and worry, by grinding the valves yourself during your spare time. The cost of a "Sioux" is less than the cost of one grinding of the valves, yet it will last a lifetime.

QUICK AND EASY TO OPERATE.

A steady turn of the handle in one direction gives the valve the reciprocating, or forward and back motion, which is absolutely necessary to perfect valve grinding. At the same time it automatically advances the valve periodically on its seat, by alternating a full turn in one direction with a three-quarter turn in the opposite direction. Thus it gradually completes the circle and insures an even grind, which means a perfect contact of all parts of the valve, with all parts of the seat.

BALL BEARINGS THROUGHOUT.

The "Sioux" Valve Grinder is ball-bearing throughout, which insures easiest action and least wear on bearings—makes the job short and easy. It has perfect balance and perfect stroke. Made of the best materials and workmanship. Will last a lifetime.

Comes complete with extension rod and four grinding bits, so that it can be used on practically any car. Packed in substantial box. Shipping weight, 4 lbs.

H7424—Our Reduced Price. 2.55

Handy Valve Grinder for Fords

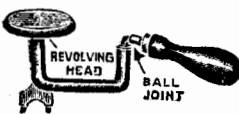

This is the most convenient and easiest operated Valve Grinder on the market. Instead of the usual elbow and wrist breaking motion employed, it is operated by a direct pull and

push motion, the ball joint taking care of all upward, downward or side motions, so that the hand may be moved in a natural manner.

The revolving brace grip on head is sufficiently high to prevent striking the fingers with the handle yet is low enough to enable the operator to grind the No. 8 (which is the last valve and practically under the dash) as quickly and easily as any of the other valves. Shipping wt., 1 lb.

H7432—Each, Our Reduced Price.42

Brace Type Valve Grinder



Very handy for grinding all Ford valves. Has long 11-inch shank and swivel bit. Shipping weight, 2 lbs.

H7427—Each, Our Reduced Price.60

Genuine "SIOUX" Valve Tools

FOR FORD AND CHEVROLET CARS

Most wonderful low priced tools ever invented for producing perfect fitting valves and valve seats in your car. These tools will line up a worn valve or valve seat better in five minutes than an hour of grinding.

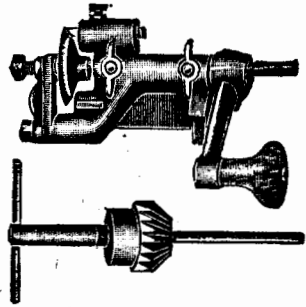

When your valves are badly pitted it is nearly impossible to get a perfect seat and the tools shown

are designed to overcome this difficulty. The reamer reams out the valve seat and the re-facer trims the valve to exactly the right angle. When your valves are worn you can of course get new ones, but new valves will not fit worn valve seats until the seats are reamed out smooth. You should always use these tools on your valves and valve seats before beginning to grind valves. These tools are well made and will do the work as well as a set costing five times their price. Every man who grinds his own valves needs this outfit. Made of the very best tool steel and fully guaranteed.

H7397—Pair (Shipping weight, 3 lbs.) 2.60
H7398—Refacer only, (1 1/2 lbs.) 1.30
H7399—Reamer only, (1 1/2 lbs.) 1.30

Sioux Valve Grinding Outfit

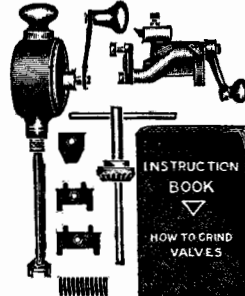

Most car owners neglect their valves, because they do not realize how important it is to keep them in perfect shape, and how easy it is to do this with the proper tools.

This outfit consists of the grinder, refacer and reamer shown above, a valve release spring and a book of instructions. This book is very complete with many illustrations showing every operation in

detail, making it easy for a beginner to do a perfect job. This book alone may be worth the price of the whole outfit to you. Grinder has extra bits to fit all cars. All tools fully guaranteed. Shipping weight, 8 lbs.

H7580—"Sioux" Valve Grinding Outfit, complete 5.45

Favorite Valve Grinder for Fords

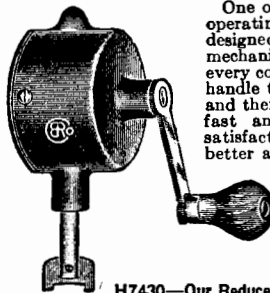

One of the very best and easiest operating valve grinders ever designed for the Ford. Gear mechanism so arranged that with every complete turn of the crank handle the valve makes a turn and then a reverse turn. Works fast and has given complete satisfaction. Will grind a valve better and in half the time required with an ordinary tool. Has a short shank so as to reach the valve under the dash on a Ford. Shipping weight, 3 pounds. Reg. List Price, \$2.50

H7430—Our Reduced Price 1.85

Bit Brace Valve Grinder

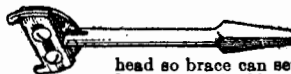

Blade is adjustable to fit any valve. Has swivel head so brace can set at an angle. Shank fits any standard brace. Ship. wt., 8 oz.

H7389—Each. Our Reduced Price.25

Grind Your Own Valves and Save Repair Bills ¹⁰⁷

Automatic Valve Lifter

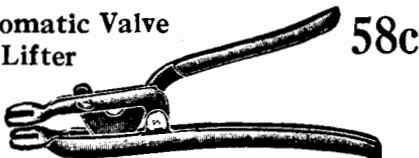

58c

An easy-working valve spring lifter which automatically locks open when handles are squeezed together, so valve can be ground, if desired, without removing lifter. Separating handle instantly releases spring. Ship. wt., 1 lb. H7404—Each..... **.58**

Toggle Valve Lifter

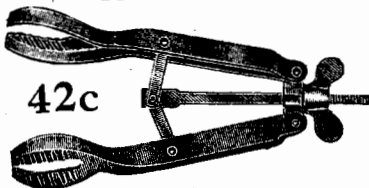

42c

A combination valve lifter and spring compressor that will do the work quickly and efficiently. Can be used on practically any car made and will hold the valve and spring in position without danger of slipping. Has simple screw action. Easy to operate. Made of strong steel. J7894—Complete (ship. wt., 1½ lbs.)..... **.42**

W. W. Junior Valve Lifter

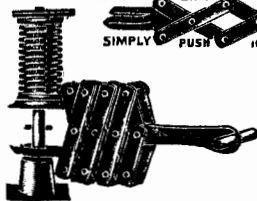

An unusually powerful, easily-operated valve lifter with parallel lift, which avoids all danger of slipping. Simply push on handle to compress spring and pull out to release it. Self-locking. All steel, with hardened lifting jaws. For use on practically any make of car.

J7877—Complete (ship. wt., 2 lbs.)..... **1.85**

Clover Valve Grinding Compound

This well-known brand has long been a favorite with motor mechanics. Extra hard, sharp, abrasive. Best grease binder. As soft as a fine vaseline, ye. it will hold the abrasive in perfect mechanical mixture in temperatures over 200 degrees. Non-magnetic and will not remain in the pores of cast iron after use. Saves both time and labor, as well as insuring best results. Packed in handy double-end air-tight screw lid box, with equal quantities of both fine and coarse. Shipping weight, 6 oz.



Our Reduced Price

H7443—4-oz. can..... **.42**

Valve Lifter

34c



Can be adjusted in an instant by using only one hand. The ratchet holds it in whatever position it is left, and leaves both your hands free to remove valve pin. Made of strong material. Shipping weight, 1½ lbs. H7400—Our Reduced Price, each..... **.34**

Chain Valve Spring Lifter

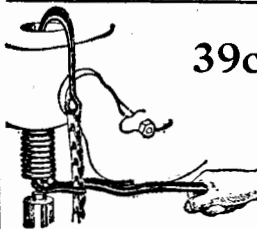

39c

The chain allows quick operation around pipes and adjacent fittings. Valve replaced as easily as removed. A tool that can be used on practically any car made. Shipping weight, 1 lb. H7409—Each..... **.39**

Valve Re-facer and Re-seater FOR FORD CARS



These tools are for the same purpose as those shown on opposite page but are more cheaply made. While they are good value for the money, they cannot be expected to have the high grade material and accurate workmanship of the fine "Sioux" tools. These cheaper tools are all right for those who only intend to use them a few times. H7395—Per pair. (Shipping wt., 2½ lbs.)..... **.79**

Kwik-Ak-Shun Cylinder Compound For Fitting Pistons and Rings



A superior compound for lapping in pistons. Will do a better job in less time than any other compound on the market. The only compound that will not imbed itself in the metal. The coarse particles break down in use, leaving a fine powder that produces a highly polished finish, as well as preventing too much metal from being taken off. With this compound, any one can fit pistons as well as a mechanic.

H7456—8 oz. can Cylinder Compound, with full instructions..... **.78**

Western Valve Grinding Compound



Put up in a special tin box with opening on each side and contains two grades—coarse and fine. Shipping wt., 4 oz.

H7440—Per Box..... **.19**

Water-Mixed Valve Grinding Compound

Grind with Water. Quick, Easy and Economical. This is the logical grinding compound. You don't put grease on a grindstone, because grease is a lubricant and retards friction, which is necessary for grinding.

That is why our water-mixed compound has become so popular with motor mechanics, on account of its efficiency and quick action. In using, it is only necessary to wipe the valve and seat with damp waste before and after using.

It is impossible to ring or score a valve with this compound because grease neutralizes it. Not necessary to use two grades of compound as the particles of abrasive break down in use and leave a fine smooth finish. Handy rust-proof can, with full instructions. Satisfaction or your money back. Ship. wt., 6 oz. H7459—Our Reduced Price..... **.34**



Genuine Kraeuter Slip Joint Pliers EXTRA QUALITY



Every mechanic knows what the name Kraeuter means on pliers. The model shown here is one of the most popular styles in the line. Forged from high carbon steel and accurately machined. Nickel-plated and has knurled handles. Wire cutter on handle side. Jaws so constructed that they will adjust themselves to any taper. Its construction gives this plier double the strength of any similar plier. Will grip pipes 1/2 to 1 1/4 inch in diameter. The teeth are so placed that the harder you grip the deeper they bite. This is really a 7 inch plier that will do the work of any ordinary 10-inch plier and do it better. Made for the man who wants the best. Shipping weight, 1 lb.

H7289—Our Reduced Price..... 1.05

"Thin Nose" Slip-Joint Pliers

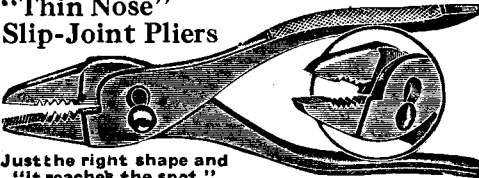

Just the right shape and "it reaches the spot."

A plier with very thin nose, handy for working in tight places where ordinary pliers would be useless. Has wire cutter, pipe grip and slip-joint feature. Full nickel plated, with fancy knurled handles. Made of fine tool steel, fully guaranteed. Shipping weight, 1 lb. **Our Reduced Price**

H7311—6 1/2" thin nose pliers..... .55

"Perfect Handle" Screw Drivers

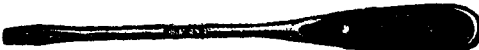

This is the most durable screw driver on the market. Made of high grade steel, the blade and handle all in one piece, with pieces of hardwood inlaid on sides of handle, making an attractive, well finished tool. Av. ship. wt., 8 oz.

H7179—4 in. blade..... .37

H7180—6 in. blade..... .37

H7131—8 in. blade..... .48

Our regular wood handle screw drivers are good quality material. Average shipping wt., 10 oz.



H7306—Regular 2" blade, small size..... .10

H7307—Regular 4" blade, medium size..... .12

H7308—Regular 6" blade, large size..... .15

Extra Quality Heavy Screw Drivers



Well made, strong and durable. Heavy wood handle, high grade steel blade, which runs all the way through handle. Shipping weight, 1 lb. **Our Reduced Price**

H7312—4-inch Blade..... .32

H7313—6-inch Blade..... .42

H7314—8-inch Blade..... .56

H7315—"Jumbo" 1/2-inch square blade, 4 in. long..... .58

4-in-1 Screw Driver

Our 4-in-1 screw driver is a very handy tool; the three small ones telescope inside of large one. Length 6 inches. Made of tempered carbon steel, very serviceable. Especially suitable for lamp sockets and all electrical work. Ship. wt., 8 oz.

H7304—4-in-1 Screw Driver..... .45

Combination Pliers 16c

Made of drop-forged steel, accurately fitted and well made. Length 6 inches. Shipping weight, 8 oz.



H7260—Black finish.....
H7261—Nickel finish.....

Our Reduced Price
16c
.25

Diagonal-Cut Pliers

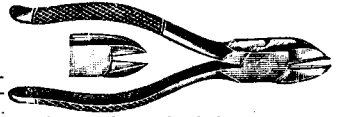

High quality diagonal-cutting pliers, 5 inches long. Cut very close and can be used in confined places. Edges perfectly fitted and meet accurately at all points. Very handy for working with insulated wire. Ship. wt., 1 lb.

H7291—5 inch, Black finish..... 1.10

Extra Quality Combination Pliers

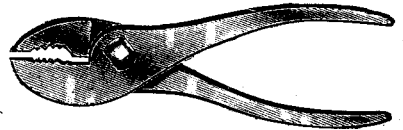

A high quality plier with that perfect balance which is so well liked by mechanics. Drop forged from 60 carbon steel, thoroughly tempered, with cutting edges hand ground. Holes are drilled before punching thereby making the joint much stronger than ordinary pliers. Nickel-plated, 7 inches long. A guaranteed plier that you will be proud to own. Shipping weight, 1 lb. **Our Reduced Price**

H7275—7 inch combination pliers..... .68

H7276—Special 5 in. nickel pliers, fine for close work..... .45

Long "Needle-Nose" Pliers

Long nose, tapered to a small point, to handle delicate and "hard-to-reach" work. Excellent for fine electrical work, also carburetors and other parts where you have to handle small springs, screws or parts. Has side-cutting feature and comes in handy for a score of uses. Gun metal finish, with polished head and knurled handles. Made of fine quality spring-tempered steel. Shipping weight, 8 oz. **Our Reduced Price**

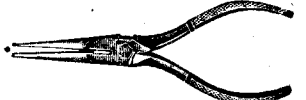

H7350—6" needle nose pliers..... 1.19

Extra Quality 10-inch Pliers

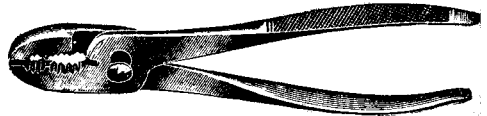

An extra heavy combination plier with great strength and leverage. Drop-forged steel, with knurled handles that won't slip. Made with wire-cutter and screwdriver. A very handy tool for the mechanic and the car owner. Shipping weight, 2 lbs. **Our Reduced Price**

H7284—10-inch Extra Quality Pliers..... 1.18

Magneto Post Screw Drivers

Extra short screw drivers, but very strong. Especially adapted for use on the Ford magneto post, or any similar close place where a short, strong screw driver is required. About 5" long over all. Shipping weight, 8 oz.

H7318—With thick handle..... :28

H7319—With slim handle..... :18



Reamers For Ford Bushings



Extra quality spiral fluted reamers, best tool steel, accurately finished. When putting in new bushings it is very necessary to have these reamers. Ship. wt. each, 1 lb.

H7373—For Spindle Bushings No. 2713-271495
H7374—For Piston Pin Bushings No. 3022 1/4	1.18
H7375—For Cam Shaft Bushings No. 3042-3-4	1.55
H7376—Valve Stem (3/4 oversize) No. 3052B	1.29
H7377—Push Rod (3/4 oversize) No. 3058B	1.78
H7378—Trans.—Triple gear flanged bushing No. 3314 1/2	1.18

(No. H7373 also fits spring perch bushings)

Main Bearing Reamer



It pays to have the proper tools and do your own repairing. This reamer aligns and smooths all three crank shaft bearings at one operation and can then be shifted to ream connecting rod bearings. It leaves a finished, perfect fitting, glass-smooth bearing, which will wear well. It is the most accurate method ever devised for truing or fitting main bearings, and does away entirely with hand scraping or burning in. Made of finest quality tool steel. Shipping weight, 10 lbs. **Our Reduced Price**

H7379—Main Bearing Reamer	11.90
---------------------------	-------	--------------

Bushing Removers

For removing spindle body and spindle arm bushings and piston bushings. Handle of spindle body bushing remover is inserted and tool is pulled through until expanders slip over inside end of bushing. Tapping with hammer removes bushing. Shipping weight, 8 oz.

H7384—Spindle Body Bushing Remover	.29
H7385—Spindle Arm Bushing Remover	.29
H7386—Piston Bushing Remover	.22

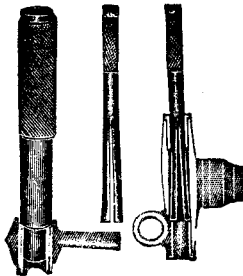

Cold Chisels



Made of high grade material, nicely finished. Shipping weight, each, 8 oz. **Our Reduced Price**

H7287—1/2-inch diameter, 6 inches long37
H7288—3/8-inch diameter, 6 inches long37

Machine Punches

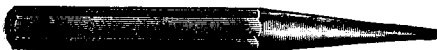

Average shipping weight., 8 oz. **Our Reduced Price**

H7281—1/2-inch diameter, 6 inches long25
H7282—1/2-inch diameter, 8 inches long30

Center Punches



Average shipping weight, 8 oz. **Our Reduced Price**

H7293—3/8-inch diameter, 4 inches long20
H7294—1/2-inch diameter, 6 inches long25

Handy Ratchet Wrench

For Ford Transmission Bands

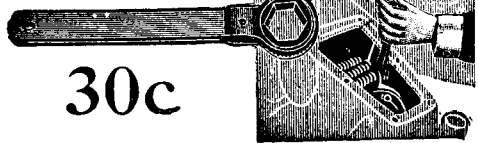

30c

The handiest wrench for adjusting the nuts on Ford transmission, reverse and brake bands. It is very difficult to adjust these nuts without a special wrench. The ratchet feature makes this wrench work very fast. This adjustment should always be made accurately; if the bands are too tight they will "drag," wearing out the lining and consuming part of the power of the motor as well as wasting gasoline. If too loose they will fail to hold safely. Avoid accidents, unnecessary wear and expense by keeping your transmission bands properly adjusted with the proper tool. Ship. wt. 8 oz. **H7154—Handy Ratchet Wrench... .30**

Extra Quality Ball Pein Hammers



An extra quality drop forged hammer for auto owners who want highest grade tools. Head of best grade drop forged steel, pein and face polished. Black handle of best grade hickory. Fully guaranteed. **Our Reduced Price**

H7886—8 oz.78
H7887—12 oz.82
H7888—16 oz.88

Ball Pein Hammers



Good quality, nicely finished, with good strong handles

H7320—8 oz.34	H7321—12 oz.39
H7322—16 oz.42			

Hub Cap Wrench

Made of pressed steel. Fits hub caps, spindle nuts and some makes of spark plugs. Shipping weight 1 lb.



H7186—Each **.10**

Socket Nut and Bolt Holder

For Ford Cars

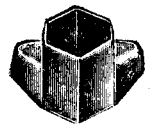

A REAL TIME SAVING DEVICE. Takes the place of "that other man." Simply slip Nut and Bolt Holder over the top of each engine or transmission nut or bolt head; the wings protruding above the hex socket engage w all of crank or transmission case and prevent nut or bolt head from turning while you unscrew the bolts underneath the car.

Made of heavy pressed steel, with reinforced wings welded to body of socket. All case-hardened and finished bright. Ship. wt., each, 4 oz. | H7269—Each **.18**
 Lot of 6 **.90** | Lot of 10 **1.50**

Pin Punches



8 inches long—points 3 1/2 inches long. Average shipping weight about 8 oz. **Our Reduced Price**

H7295—With point 3/4" diameter24
H7296—With point 1/2" diameter29

Connecting Rod Wrench



Reaches connecting-rod bearing by simply taking bottom plate off crank case. This is the first wrench made to fit the fourth connection. One of the handiest Ford wrenches made. Made of best grade Steel. Absolutely guaranteed. Shipping weight, 1 lb.
H7106—Our Reduced Price..... .28

Ratchet Connecting Rod Wrench



A ratchet connecting rod wrench that will get at the back bearing in a jiffy. Also fits cylinder head bolts, rim lug nuts, etc. Highest quality. Fully guaranteed. Shipping weight, 1½ lbs.
J7798—Our Reduced Price..... 1.48

Tee Flex Wrench

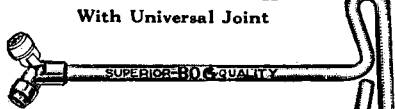

With Universal Joint
 SUPERIOR-BOC-QUALITY

Socket size ¾-inch hex. Length over all, 13¼ inches. Especially fine for Ford connecting rod bolts, also fits cylinder head cap screw, water inlet connection cap screw. Solid steel. Shipping weight, 1½ lbs.
J7802—Our Reduced Price..... 1.45

Any Angle Socket Wrench



FRICITION BALL

Has friction ball socket which adapts it for work in close places. Especially useful for back connecting-rod bolts on Ford cars. Also fits cylinder head bolts, commutator case, demountable rim nuts, etc. Socket size, ¾-inch hex; handle 11 inches long. Made from cold-rolled steel, white nickel finish.
H7576—Each (ship. wt., 2 lbs.)..... .72

Crank Case Lower Cover Wrench

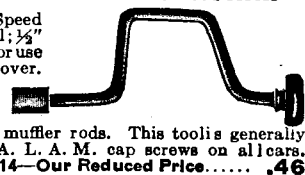

Special designed Speed Wrench 12½" over all; ½" socket, particularly for use on crank case lower cover. Also used on axle housing, differential drive, front and rear fenders and muffler rods. This tool is generally useful on all 5/16" A. L. A. M. cap screws on all cars. Weight, 1½ lb. **H7114—Our Reduced Price..... .46**

Adjustable Auto Wrench



An adjustable drop forged wrench suitable for heavy work. Solid one-piece movable jaw. Length, 9 inches.
H7152—Each (shipping wt., 1½ lbs.)..... .29

Genuine Stillson Wrenches

Wood Handle, Drop-Forged Steel Jaw.



The wrench that stands the test. Made of highest grade materials and absolutely guaranteed in every detail.
H7157—Size 6" Takes pipes ½ to ¾ in. (wt. ½ lb.)..... .72
H7158—Size 8" Takes pipes ¾ to 1 in. (1½ lb.)..... .79
H7159—Size 10" Takes pipes 1 to 1¼ in. (2 lbs.)..... .89
H7160—Size 14" Takes pipes 1¼ to 1½ in. (5 lbs.)..... 1.28

Genuine "Williams" Wrenches

Very high quality steel, tempered and semi-finished
 Average ship. wt. 8 oz.



15 DEGREE ANGLE ENGINEERS' WRENCHES

Our No.	Openings Milled	Williams Number	Length Inches	Price Each
H7212	1 & 1/8"	21	3 3/4"	.17
H7213	1 & 1/4"	23	4"	.20
H7214	1 & 1/2"	25	4 3/8"	.23
H7215	1 & 3/4"	27	5 1/8"	.26
H7216	1 & 7/8"	29	6 1/8"	.30
H7211	1 & 1/2"	31	7 1/4"	.42

15 DEGREE LIGHT CAP-SCREW WRENCHES

Our No.	Openings Milled	Williams Number	Length Inchs	Price Each
H7207	3/8 & 1/2"	723	4"	.22
H7208	1/2 & 5/8"	725	4 3/8"	.25
H7209	5/8 & 3/4"	725-B	4 7/8"	.28
H7217	3/4 & 7/8"	727	5 1/8"	.32
H7218	7/8 & 1"	729	6 1/8"	.36
H7219	1 & 1/8"	731	7 1/4"	.42

Connecting Rod Clamp Screw Wrench

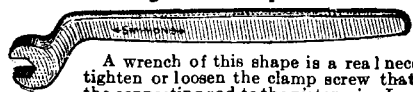

A wrench of this shape is a real necessity to tighten or loosen the clamp screw that fastens the connecting rod to the piston pin. Length 10"
 Shipping wt., 1 lb. **H7165—Our Reduced Price... .32**

Double End Socket Wrench



An Offset Socket Wrench 1 1/8" and 3/4" with 9" handle. Used on brake shoe support, connecting rod clamp, crank shaft (main) bearing, fan bracket spindle, steering gear post, steering post bracket spindle, connecting rod and front radius rod.
H7108—Each (Shipping weight, 1 1/2 lbs.)..... .38

Double Socket Wrench



Socket sizes, 1 1/8-inch square and 1 1/8-inch Hex. Length over all 9 inches. Fits head of main bearing bolts, connecting rod clamp screw, running board bolt nut, running board to fender bolt nut. Shipping weight, 1 1/2 lbs.
H7110—Our Reduced Price, Each..... .48

Triple Socket Wrench



The new improved "Tomahawk" wrench, 5/8 inch and 3/4 inch hexagon socket. Made especially for clearance around cylinder head bolts, also fits brake and reverse support, water intake and outlet screws, differential case, drive case, drive shaft and roller bearing, rear axle housing crank case (lower cover). Made of best grade Steel. Shipping weight, 1 lb.
H7122—Our Reduced Price..... .35

Fly Wheel Wrench



Used on the fly wheel cap screws. Size of socket 1 1/8". It has been considered an impossibility to reach these screws with a socket wrench. Here is a strong wrench that makes this ugly place accessible. Shipping wt. 1 lb.
H7103—Our Reduced Price..... .29

FORD OWNERS WRENCH SET

"JUST THE WRENCHES YOU NEED FOR THE FORD"

Finest quality Wrenches made. Every socket accurately cut from fine bar steel.

\$1⁷⁵ Complete Set

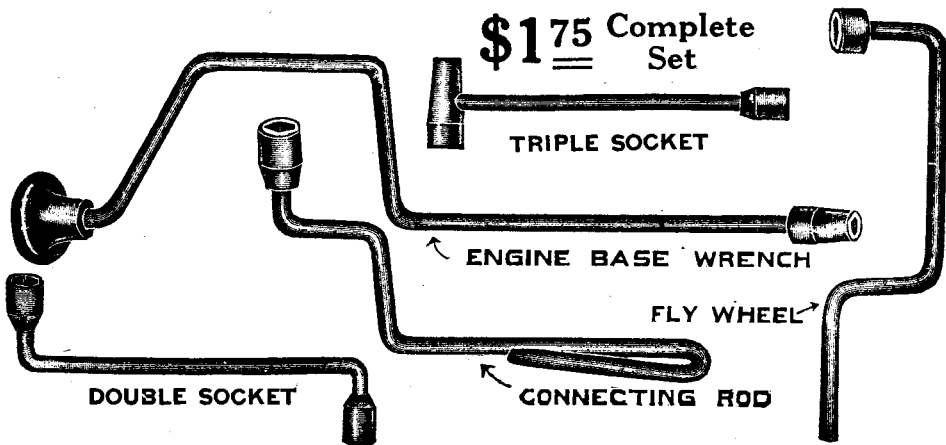

There are many nuts and bolts on the Ford car which cannot be reached without special wrenches. These tools are made of the finest material and especially shaped to reach practically every place on the Ford. Every Ford owner and repair man should have a set. The set includes the five wrenches most frequently used, one each of the following:

TRIPLE SOCKET WRENCH.

Socket size $\frac{5}{8}$ in. and $\frac{1}{2}$ in. hex. This is improved "Tomahawk" wrench. The double end socket has been designed particularly for clearance around cylinder head bolts and other places. Used on cylinder head, brake and reverse support, cylinder inlet and outlet connections, differential case, drive shaft roller bearing, front spring tie bolt, running board bolts, rear axle housing, crank case lower cover, controller shaft bracket.

CONNECTING ROD WRENCH.

$\frac{5}{8}$ -inch hex. socket. Fits all connecting rods, including the fourth. This is the original design, the first wrench made to reach the fourth connecting rod without removing the engine from the car.

LONG SHANK BRACE SOCKET WRENCH.

11-inch shank. 9-16 inch socket. For use on trans. cover nuts, engine base bolts and many other places.

DOUBLE SOCKET OFFSET WRENCH.

Socket sizes 9-16 in. and $\frac{3}{4}$ in. handle 11 in. Used on brake shoe support, connecting rod clamp, crank shaft (main) bearing, fan bracket spindle, steering gear post, steering post bracket, spindle connecting rod, and front radius rod. Fits main bearing bolt heads.

FLYWHEEL WRENCH.

Socket size 11-16 in. hex. Used on flywheel cap screws, heretofore considered an impossible place for a socket wrench. A difficult place made accessible.

Order this set of wrenches and be prepared to make all adjustments and do all the repairing necessary on your Ford car. Shipping weight, 7 lbs.

H7100—Complete Set of Five Wrenches 1.75

T Handle Socket Wrenches

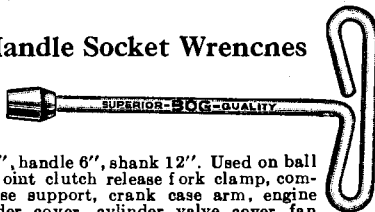

Socket $\frac{1}{2}$ " handle 6", shank 12". Used on ball and socket joint clutch release fork clamp, commutator case support, crank case arm, engine bolts, cylinder cover, cylinder valve cover, fan adjustment, front radius rod ball, inlet exhaust clamp and muffler bracket. Shipping weight, 1 $\frac{1}{2}$ lbs.

H7116—Our Reduced Price37

Socket $\frac{3}{8}$ " for brake and reverse and brake shoe support, cylinder inlet and outlet, cylinder head, drive shaft roller bearings, front and rear spring tie bolt. Ship. wt., 1 $\frac{1}{2}$ lbs.

H7118—Our Reduced Price37



Heavy Duty Socket Wrench

A Triple Socket Offset Wrench. Socket eyes $\frac{1}{2}$ ", $\frac{3}{8}$ " and $\frac{1}{4}$ ". Built especially for heavy duty; used on drive shaft pinion, front spring clip, hub bolts and nuts, radius, rod rear hub block, rear spring clip, spindle arm and body bolts. Made of best grade Steel. Ship. wt. 2 $\frac{1}{2}$ lbs.

H7112—Our Reduced Price68

Speed Wrenches



Highest quality steel wrenches with sockets machined from solid bar and broached accurately to size. Every wrench guaranteed. Indispensable for fast work on automobiles. Length over all, 18 $\frac{1}{4}$ in. handle 6 in., shank 12 in. Made of best grade Steel. Ship. wt., 2 lbs.

HANDIEST SIZES FOR FORD CARS

Socket opening $\frac{1}{2}$ in. for ball socket joint, clutch release fork clamp, commutator case support, crank case arm, engine bolts, cylinder cover, fan adjustment, front radius rod bolt inlet and exhaust clamp, transmission cover and universal bolt on Ford cars.

H7128—Our Reduced Price48

Socket $\frac{3}{4}$ inch, handle 6 inches, shank 12 inches. Fits brake and reverse support, brake shoes support, cylinder inlet and outlet connections, cylinder head, drive shaft roller bearings, front and rear spring tie, running board, fender and controller shaft on Ford cars.

H7129—Our Reduced Price48

OTHER SIZES FOR ALL CARS

- J7670—Socket opening $\frac{1}{4}$ inch, each48**
- J7671—Socket opening $\frac{1}{2}$ inch, each48**
- J7672—Socket opening $\frac{3}{4}$ inch, each48**
- J7673—Socket opening 1 inch, each48**

Superior Socket Wrench Set

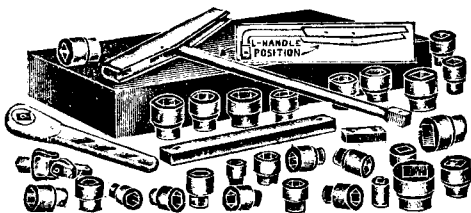

A wrench set that will let you get at practically any bolt or nut on any car, truck or tractor. Consists of Ratchet Wrench, Long Extension Bar, Short Extension Bar, Universal Joint, and Combination Tee-and-Offset-Handle, together with 19 hex and 8 square sockets, handily assembled in a metal box. Openings of hex sockets are 5-16, 11-32, 3/8, 7-16, 1/2, 9-16, 19-32, 5/8, 11-16, 3/4, 25-32, 13-16, 3/4, 15-16, 31-32, 1, 1-1/16, 1 1/8, and 1 1/4. Openings of square sockets are 3/8, 7-16, 1/2, 9-16, 3/8, 11-16, 3/4 and 1. Sockets are machined from a special cold-rolled solid steel bar; every socket guaranteed unbreakable. Handles, extension bars and universal joint are best grade steel, satin-nickel finish. A wrench set to be proud of.

H7586—Complete set (ship. wt., 10 lbs.)..... **6.85**

Favorite End Wrench Set

52c

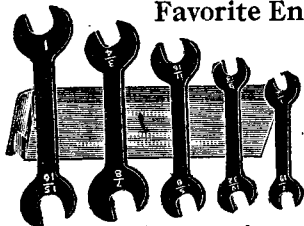

Made of heavy steel, convenient size. Strong and durable. Beautifully nickel-plated. All wrenches of uniform thickness. Set consists of five wrenches, furnishing ten popular standard openings. Sizes as follows: 7-16", 1 1/2", 9-16", 19-32", 5/8", 11-16", 3/4", 7/8", 15-16", 1". Packed in paper box. Ship. wt., 3 lbs.

H7196—Set of 5 Wrenches as shown..... **.52**

Combination Tap and End Wrench Set



A handy set of five end wrenches, with openings ranging from 1/2" to 1", having also center openings for use as tap wrenches, fitting the most popular sizes. Stamped from a special

grade of steel, and hardened to stand rough usage. Packed in paper box. Shipping weight, 1 1/2 lbs.

H7328—Set of 5 wrenches as shown..... **.42**

Transmission Band—Gasoline Line Wrench FOR FORD CARS



Specially designed to fit two places on Ford cars that are difficult to reach, with a head for each one. Its extra length make it especially convenient for use, as well as for finding quickly in the tool box. 8 in. long; black finish. H7193—Each (ship. wt., 8 oz.)..... **.28**

Williams End Wrench Set FOR FORD CARS

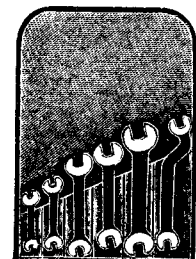

A set of genuine Williams drop-forged semi-finished end wrenches in canvas roll. Consists of six wrenches—12 openings—that will care for every nut on a Ford car. The thin offset reverse-gear wrench is specially designed for adjusting reverse gear and brakes. Every wrench carefully inspected and fully guaranteed. Shipping weight, 3 lbs.

H7205—Set complete with roll..... **2.65**

All-Purpose Socket Wrench Set

FOR ALL CARS AND TRACTORS

\$3.95 COMPLETE SET

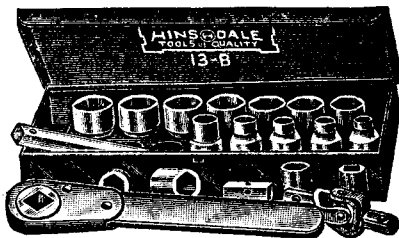

A high-grade socket set for use on any car or tractor. With this set you can practically overhaul your car, no matter what make it is. Made of heavy cold-rolled steel and nicely finished. Sockets are standard type and will fit standard handles. Packed in strong metal box, containing ratchet handle, 9 inches long, extension bar, 8 inches long, universal joint 1 1/2 hex, and one 1/2 in. square socket. Openings of hex. sockets are 5-16, 11-32, 3/8, 7-16, 1/2, 9-16, 19-32, 5/8, 11-16, 3/4, 25-32, 13-16, 3/8, 15-16, and 1 inch.

H7584—Complete (Shipping weight, 6 lbs.)..... **3.95**

H7578—Ratchet handle only. (Ship. wt., 1 lb.)... **.80**

Quickway Socket Set

Here is a high quality socket set that every car owner should have.



Has five sockets, machine turned from high carbon steel and case hardened by special process which gives them long life under the most severe use. Handle is tough steel with ball in both ends so that either end of handle can be inserted in socket. Sizes of sockets, 1/2, 3/4, 7/8, 1 1/8 and 1 1/4 inches. Packed in neat leatherette case.

H7133—Complete Set. (Ship. wt., 1 lb.)..... **.68**

Handy Socket Wrench Set

Has the famous combination Tee-and-Offset-handle, with ten solid cold-rolled steel sockets, guaranteed unbreakable.

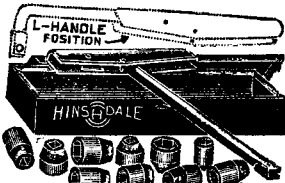

Socket-openings, 7-16 1/2, 9-16, 19-32, 3/8, 11-16, 3/4, 25-32, 13-16, 3/8, all hex. Handle and sockets are satin nickel finish. Comes complete in heavy fiber box. An unusual value.

H7585—Complete set (ship. wt., 3 lbs.)..... **1.68**

Bethlehem Special Wrench Set

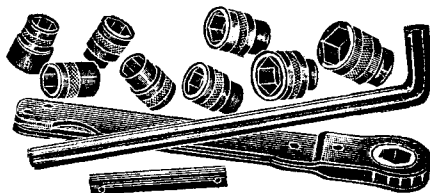

One of the most popular socket sets on the market. Has regular handle, ratchet handle, and extension bar, and 8 sockets—1/2, 3/4, 7/8, 1 1/2, 1 3/8, 5/8, 1 1/8 and 3/4. Makes it easy to get into difficult places; fits practically any bolt on any car. Highest grade sockets, machine turned. Will stand up under hard usage. Ship. wt., 3 1/2 lbs.

H7202—Our Reduced Price. Complete set..... **2.28**

Handiest and Best FOR ALL-AROUND USE

With this handy set of 3 Handles and 8 Sockets you have the equivalent of 32 ordinary socket wrenches in compact, convenient form.

Always ready for use. No more loss of time hunting for the wrench you need. And you don't have to carry around a whole machine shop load in order to have the size or angle that you need for the job. Set consists of handy Speed Handle, Rim or Brace Handle, and new improved combination Tee- and Offset-handle, and 8 of the most popular standard sized sockets. These sockets are all interchangeable with any one of the handles—in short, you just slip the socket you need on the most convenient handle, and you are ready for the job. There is nothing to get out of order. Sockets snap on or off with ease. A friction ball holds sockets securely in place on handles.

These wrenches are made of the best-grade, half-inch steel Parkerized to prevent rust, extraordinarily strong and well finished. The sockets are machined from solid steel bars, accurately broached 1-64 inch over-size to insure perfect fit. The hexagon openings are slightly counter sunk to allow the rapid placing of sockets on the bolt or nut. Both handles and sockets are scientifically hardened and absolutely rust-proof.

With a complete set of these wrenches you will be fully equipped to reach practically every bolt or nut on a Ford car or truck, Fordson tractor, or in fact on any automobile made. They will pay for themselves many times over every season in the savings on repair bills.

For the benefit of those who do not wish a full set at

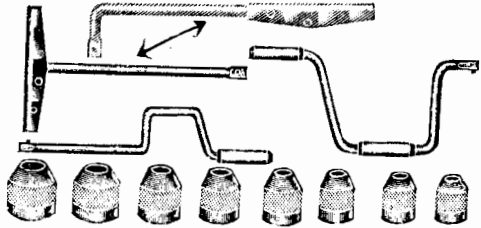

once, we list the handles and sockets separately, so you can get what you need now, and gradually add to that until your set is complete.

Sockets are made to fit hex nuts and bolt heads, and are furnished in the sizes shown below. Sizes represent size of socket opening, and not the size of the bolt or nut.

Every handle and every socket is fully guaranteed.

- | | |
|---|-------------|
| H7242—Complete set, three handles and eight sockets, as illustrated above (ship. wt., 10 lbs.)... | 2.95 |
| H7220—Speed Wrench, handle only (wt., 2½ lbs.) | .58 |
| H7221—Rim or Brace Wrench, handle only (2½ lbs.) | .58 |
| H7235—Combination Tee- and Offset-handle only (wt., 1½ lbs.) | .68 |
| H7225—1/4" socket... | .18 |
| H7226—3/8" socket... | .18 |
| H7227—1/2" socket... | .18 |
| H7229—5/8" socket... | .18 |
| H7230—1/4" socket... | .18 |
| H7231—3/8" socket... | .18 |
| H7232—1/2" socket... | .18 |
| H7234—5/8" socket... | .18 |
| H7243—Complete set of eight sockets (2½ lbs.) | 1.35 |

"Knockout" Wheel Pullers

Pulls a wheel in one third the time required with any other puller. Pulls all makes of wire wheels. Leaves axle in perfect condition. Just remove axle nut, screw on the "Knockout" strike sharp blow—wheels off. Shipping weight, 1 lb.

- | | |
|---|------------|
| H7367—Fits Ford, Star, and Chevrolet 490 and Superior..... | .45 |
| H7368—Fits Chevrolet F. B., Dort, Franklin, Maxwell and Moon..... | .45 |
| H7369—Fits Chalmers, Chandler, Cleveland, Columbia, Empire, Essex, Ford Ton Truck, Grant, Hudson, Lexington, Monroe, Mitchell, Nash, Oakland, Oldsmobile 6, Paige, Roamer, Stephens, Studebaker, Templar, Velie, Wescott..... | .45 |

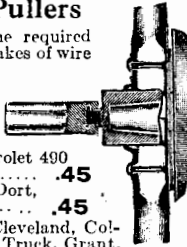

Adjustable Wheel Pullers FOR FORD AND CHEVROLET 490

With this device, a rear wheel of a Ford or Chevrolet 490 car may be removed without marring the spokes or spoiling the thread on the hub. Simply screw the puller on the hub and tighten the bolt with a wrench. The wheel is gradually forced off.

H7362 as shown in cut, has a loose plunger extending through the center of the screw. A sharp blow with a hammer against this plunger will loosen a wheel which is stuck to the axle. It also has a bolt on the side by which the wheel puller can be clamped down tight, making it impossible to strip threads. H7361 has side clamp like H7362 but has no loose plunger.

Our Reduced Price

- | | |
|--|-------------|
| H7361—Wheel Puller, (wt. 2 lbs.), each..... | .44 |
| H7362—Wheel Puller, with floating plunger, as illustrated (wt. 2 lbs.). Each..... | 1.18 |
| H7363—Wheel Puller for Ford Trucks, also Maxwell and 1924 Chevrolet Superior cars (4 lbs.) | 1.95 |

Handy Handle Wheel Puller

Substantial Wheel Puller designed especially for Ford and Chevrolet 490 cars. Made with extra long handle to increase leverage. Equipped with set screw for tightening puller around hub. An excellent value at our price. Ship. wt. 3 lbs.

H7303—Our Reduced Price... **.59**

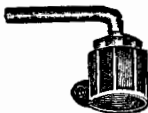

Dandy Wheel and Gear Puller

For All Around Use

A high-grade wheel and gear puller for universal use. Screw and hooks are made of fine quality steel, scientifically hardened and drawn. By changing position of the hooks, either a two, three or four hook puller may be had. This allows automobile wheels to be removed without tilting, even when they contain an uneven number of spokes. An extension bar is also furnished, providing for a wide range of adjustments, making it possible to catch the circumference of an 18" brake drum. Shipping weight, 4 lbs. Regular price \$6.00

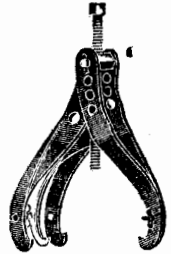

H7366—Our Reduced Price, complete..... **3.95**

Universal Wrench Set for Ford Cars

A handy wrench set that will take care of practically all needs of the Ford car owner. Includes connecting rod wrench, fly-wheel wrench, rat-het wrench for transmission bands, double-end wrench with openings 1/4" and 3/4" for crank shaft bearings, crank case bolts, differential case, etc., and triple-socket wrench with openings 1/2" and 5/8" for cylinder head bolts, rear axle housing, crank case lower cover screws, etc.

Substantially made; finished in white nickel. Comes packed in fibre carton. Ship. wt., 5 lbs. **Our Reduced Price**
K8116—Complete Set..... **1.40**

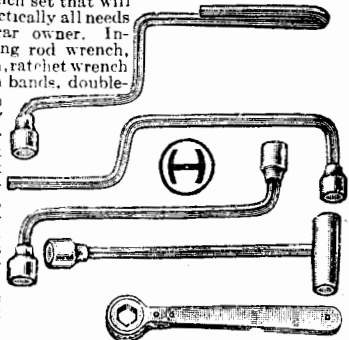

Genuine Crescent Wrenches



The strongest and handiest adjustable end wrench made. No need to hunt for the size wrench you need—the "Crescent" will do the work for you.

J7829—Size 4" (shipping weight, 8 oz.)	.65
J7830—Size 6" (shipping weight, 8 oz.)	.80
J7831—Size 8" (shipping weight, 1 lb.)	.98
J7832—Size 10" (shipping weight, 1½ lbs.)	1.25
J7833—Double-end, 6"-8" (ship. wt., 2 lbs.)	1.50
J7834—Double-end, 8"-10" (ship. wt., 3 lbs.)	

Genuine Star Hack Saw Blades



Star Hack Saw Blades are probably the best known and most satisfactory blades on the market. They are made of highest quality steel and are much less liable to break than the ordinary cheap blade. Furnished 18 teeth to inch. Average shipping weight, about 8 oz. per dozen.

Our Reduced Price—Each Price, per Doz.

H7344—8-inch	5c	.48
H7345—9-inch	6c	.50
H7346—10-inch	7c	.57
H7347—12-inch	8c	.65



Regular Hack Saw Frame

Nicely finished. Shipping weight 1 lb.

H7343—Adjustable for 8 to 12" blade. complete with blade. Our Reduced Price .39

Williams Monkey Wrenches



High-grade agricultural or monkey wrenches for general use around the garage or shop.

Has forged steel head, bar and shank. Machine cut steel adjusting screw with knurled head. One piece polished hard-wood handle. Metal parts all finished in dull black. A handy tool to have in your tool kit.

J7874—6 inch, wt., 1 lb.	50c
J7875—8 inch, wt., 2 lbs.	62c
J7876—10 inch, wt., 2½ lbs.	82c

Wrenches for Dodge Cars

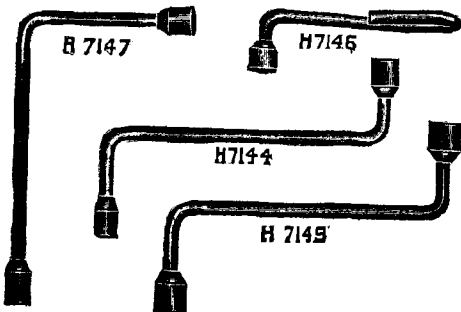

These four wrenches have been specially selected as to shape and size to meet the requirements of repair work on Dodge cars. Taken together they will get at practically every bolt and nut on the Dodge. Welded sockets, with good strong handles. Guaranteed to stand hard service. Ship. wt., each 1 lb., set 4 lbs.

H7144—Double-end wrench, socket sizes 7/8" and 9/8"	.65
H7145—Double-end wrench, socket sizes 3/4" and 7/8"	.65
H7146—Off-set wrench, socket size 1/2"	.45
H7147—Double-end "L" wrench, sockets 5/8" and 1 1/4"	.55
X8880—Complete set of 4 wrenches for Dodge	2.20

Crescent Type Adjustable Wrench



Wrench can be used in practically every opening where the solid wrench can be

used. The 10" size takes the place of nine sizes of solid wrenches. Other sizes proportionately. Very useful wrench.

H7171—Size 4" (shipping weight, 8 oz.)	.46
H7173—Size 6" (shipping weight, 8 oz.)	.48
H7174—Size 8" (shipping weight, 1½ lbs.)	.62
H7175—Size 10" (shipping weight, 2 lbs.)	.72

Handy Pistol Grip Hack Saw

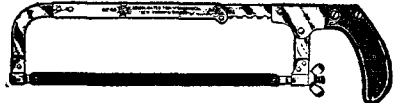

An unusual value. Convenient wood handle that fits the hand nicely. Nickel-plated frame, adjustable for 8" to 12" blades. Not quite as heavy or substantial as our "Favorite" shown below, but very serviceable. Comes complete with 8" blade. Shipping weight, 1½ lbs.

J7871—Our Reduced Price .89

Favorite Pistol Grip Hack Saw

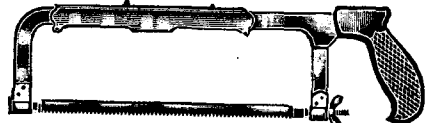

This style hack saw frame is much easier to operate than the ordinary straight handle style. Pistol grip fits nicely into the hand and permits holding the saw firmly and without "wobbling." Nickel plated frame, strong black handle, adjustable for 8-inch to 12-inch blades. A high quality tool for the man who wants the best. Shipping weight, 2 lbs.

Our Reduced Price
H7340—Complete with one 8-inch blade .1.35

Carburetor Wrench for Ford Cars

Removing the Ford Carburetor has been an exceptionally difficult task. This wrench makes it easy.



J7842—Carburetor Wrench (Wt., 1lb.) .35

Wrenches for Chevrolet Cars

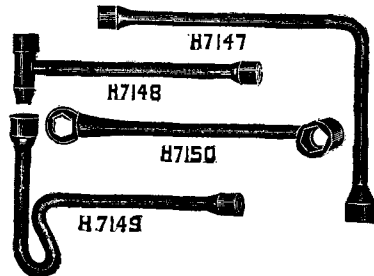

Chevrolet owners will find these wrenches just the proper size and shape for doing their own work. Will take care of practically every bolt and nut on the car, many places where the ordinary wrench will not work. Welded sockets, good strong handles. Fully guaranteed. Ship. wt., each 1 lb., set 4 lbs.

H7147—Double-end "L" wrench, 5/8" and 1 1/4" for motor support arm, steering gear clamp and tie rod	.65
H7148—Triple socket wrench, 3/8", 5/8" and 1/2" for oil pan bolts, transmission cover, etc.	.58
H7149—Tee and off set wrench, 1/2" and 3/8" for clutch yoke, cylinder head bolts, manifold nuts, etc.	.89
H7150—Box-end, 1/2" for front main bearings. Socket end 3/8" for center and rear bearings, king bolts, etc.	1.08
X8881—Complete set of 4 wrenches for Chevrolet	2.95

Favorite Hand Drill

Extra well-made, strong malleable frame, cut gears and steel pinion Ball thrust bearing, insuring long life and ease in operation.

The end handle is hollow and contains eight popular sized wood boring points. Has detachable side grip handle; has Star Chuck; will hold drills up to 1/4-inch. Chuck has self-opening jaws, actuated by springs which are so located in the base that they cannot be reached by the shank of the drill and will not be jammed out of place or get out of order. Centers well; one of the most satisfactory drill chucks made. Black enamel finished frame. Large gear, red, metal parts, nicked; cocobolo wood handles. Length 12 1/2 inches. Packed in paste-board box. Shipping weight, 3 lbs.

H7473—Our Reduced Price ... 2.98

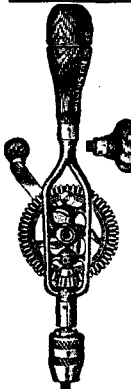

Tap and Die Set

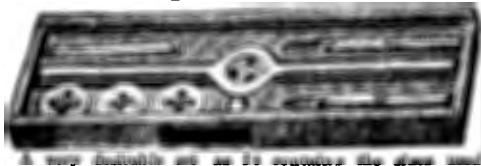

most frequently. Taps and dies are made of the very best tool steel. Set consists of a combination tap and die stock and 3 S.A.E. taps and dies to match, in the following sizes: 1/4 in., 5/16 in. and 3/8 in. Comes in slide cover box.

H7300—Tap and Die set. (Shipping wt., 1 1/2 lbs.)... 1.28

No. 10 Tap and Drill Set

Every Ford owner knows how easy it is to shear off a cylinder head bolt when tightening up and how hard it is to remove the threaded end remaining in the casting. Our No. 10 Tap and Drill Set makes the operation simple.

You don't even have to remove the cylinder head—Just slip the hardened steel bushing in the bolt hole and drill out the body of the thread with the special drill furnished; the body tap will then clean out the threads leaving them like new. (Ship. wt., 1 lb.)

H7302—Set complete... 1.45

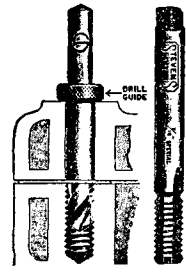

The Famous "Mr. Punch" Automatic Drill



Here is just the tool for general use around the garage or home. A nickel-plated tool, 10 in. long, with eight drill bits, sizes 1/8, 3/16, 1/4, 5/16, 3/8, 7/16, 1/2, and 5/8. Has knurled handle, containing a patented magazine which holds each of the eight drill bits in a separate numbered compartment, and magazine is provided with a drill gauge showing the exact sizes of the bits. To operate, simply put bit in chuck and push on the drill. This causes the bit to turn rapidly and the hole is quickly made.

K8150—Each, complete (Shipping wt., 1 lb.)... 2.12

K8151—Set of 8 Drills only, in wooden box... .62

"Easy-Out" Screw Extractor Set



Here is one of the cleverest devices ever invented for removing bolts, cap screws, set screws, etc., when the head has been broken or twisted off. Simply drill a hole in broken screw, insert "Easy-Out," slip on a wrench and twist to the left and the screw comes out easily without injury to threads. One of each, diam. at point, 1/4, 3/8, 1/2 in. Length about 3 1/4 in. Wt., 12 oz.

H7596—Per set of three... 1.78

H7697—Easy-Out Extractor, 1/4"... .65

H7598—Easy-Out Extractor, 3/8"... .78

H7599—Easy-Out Extractor, 1/2"... 1.10

Lightning Breast Drill

Has 2 gear ratios even and 3-1. The speed is changeable without withdrawing drill from work. The pinion is made of best grade steel, and both gears are cut. Has a ball thrust bearing, making the drill easy to operate as well as adding much to the life of the tool.

The breast plate is adjustable and the crank is extensible from 4 to 7 inches, giving added power. Has a three-jaw Star Chuck, with protected springs for round shank drills up to 1/2 inch. This is a very serviceable, all around breast drill, at a reasonable price. Stained hardwood handles. Frame rolled steel and cast iron. Large gear painted red, other parts polished. Length, 18 1/4 inches. Shipping weight, 8 pounds.

4.15

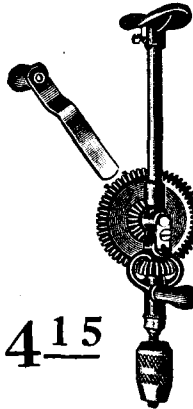

Our Reduced Price

H7467—Complete... 4.15

Handy Tool Grinder FOR GARAGE OR HOUSEHOLD USE

1.68

A good grinder is really a necessity in every garage or home. It can be used for sharpening drills, knives, chisels, etc., and for dressing down rough places on iron and steel parts of an automobile. Our grinder is absolutely highest quality throughout and should not be confused with cheap, inefficient grinders sometimes

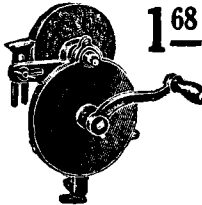

offered. Height, 8 inches; strong clamp; easy operating best emery wheel, 3 1/2 x 1 1/2 inches. Finished in high-grade dark colored enamel. Shipping wt., 4 lbs.

H7587—Complete, Our Reduced Price... 1.68

Twist Drills (Straight Shank)



Made of fine High Carbon Tool Steel, properly hardened sharpened and polished. Average shipping weight, 4 oz.

No.	Diam.	Length	Price	No.	Diam.	Length	Price
K7940	1/8"	2 1/2"	.08	K7948	1/4"	4 1/2"	.20
K7941	1/8"	2 3/4"	.09	K7949	1/4"	4 3/4"	.22
K7942	1/8"	3"	.09	K7950	1/4"	5"	.24
K7943	1/8"	3 1/4"	.10	K7951	1/4"	5 1/4"	.27
K7944	1/8"	3 1/2"	.11	K7952	1/4"	5 1/2"	.32
K7945	1/8"	3 3/4"	.12	K7953	1/4"	5 3/4"	.38
K7946	1/8"	4"	.17	K7954	1/4"	6"	.49

Square Shank Drills for Metal or Wood



Highest quality carbon steel drills, hardened and polished. Shank will fit any standard brace. Average shipping weight, 4 oz.

No.	Diam.	Length	Price	No.	Diam.	Length	Price
J7900	1/4"	3 1/2"	.12	J7904	1/2"	5 1/2"	.28
J7901	1/4"	3"	.10	J7905	1/2"	6"	.38
J7902	1/4"	4"	.18	J7906	1/2"	6 1/2"	.48
J7903	1/4"	5 1/4"	.22	J7907	1/2"	7"	.58

Twist Drill Set

Set of twist drills for wood or metal. Have square shank, so that they can be used in regular brace. Made of best grade steel. Come complete in heavy box. Set consists of one each of the following size drills: 1-16, 3-32, 1/8, 5-32, 3-16, 7-32, 1/4, 5-16, 3/8 in. Shipping weight, 1 1/2 lb.

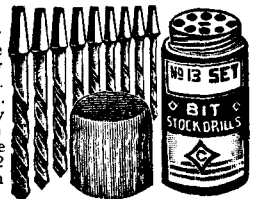

H7595—Complete set... 1.95

Running Board Tool Box

This tool box is long enough to accommodate everything you need for making repairs, including a tire pump and tools, jack, extra tubes, tire powder, etc. Made low (only 7 inches high, including lid), to permit the door of the car opening and closing above box. Made of strong steel, with black baked-enamel finish; two trunk catches and fitted with **Genuine Yale Lock**. Size, 22x9x7 inches. Shipping weight, 10½ lbs.

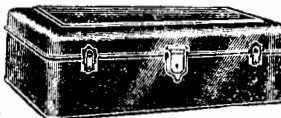

W8400—Box as shown with Yale Lock, complete with key. **1.95**

W8398—Same size tool box, with plain lock and key (not illustrated). **1.55**

NOTE—When ordering a tool box, we suggest that you order any small articles you need and have them packed in the tool box, thus saving transportation charges.

Kennedy Tool Kits

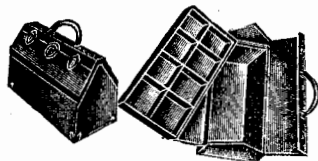

The most popular kit for mechanics or car owners. Shaped like a leather bag and made throughout of prepared steel, so that they are no heavier than an ordinary

grip. Strong and durable. Has solid brass corners, good side catches, genuine Yale lock, and leather-covered handles with steel core. Has light-weight steel compartment trays, divided by small partitions, as shown in illustration. Finished with three coats of baked-on enamel. Shipping weight, 7 lbs.

Our Reduced Price

W8394—Complete kit, size 16x9x11 inches. **4.65**

W8395—Complete kit, size 18x10x13 inches. **4.95**

File Handles

Substantial, nicely finished wood file handles. Allow a better grip that lets you do better work in less time and far more comfortably.



H7337—Each (shipping weight, 4 oz.) **6c**

Pipe Jaws

For Any Vise

Here is a very handy little device. It simply slips between the jaws of the vise and will hold pipe or any round object very securely. Every-

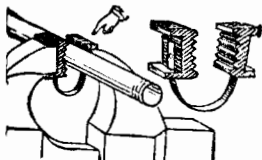

one who has a vise should have one of the jaws. Will fit any vise and hold practically any size pipe. Shipping wt., 8 oz. **H7480**—Complete, **Our Reduced Price** **.27**

Machinist's Bench Vise

Swivel Base—Made for Real Service

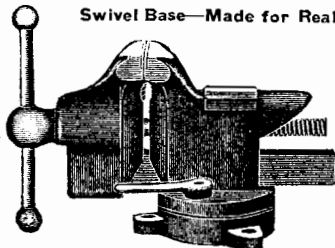

A well-made anvil-type bench vise with patented swivel base; attaches to bench with screws; best tempered steel jaws welded on, with convenient tool steel pipe jaws just below. Head to main screw forged. A nut in rear takes up all wear upon screw and also prevents lost motion. An exceptional value. Jaw 3 in. wide, opens 4 in. Ship. wt. about 22 lbs. **Our Reduced Price**

H7484—Machinists' Bench Vise. **4.35**

"SPEEDY" WRENCH for FORDS

For Transmission Cover and Engine Base Bolts

With the "Speedy" wrench one man can remove all the bolts around transmission cover without assistance, making it an easy and quick job to reline transmission bands. The saving of time on one job will often pay for the wrench. Very extensively used by Ford repair men. Well made of best grade steel, satin nickel finish. Both the brace wrench and the bolt holder have fine machined sockets. The bolt holder works on a slide on the shank of beam wrench and a coil spring holds it securely in place while in use.

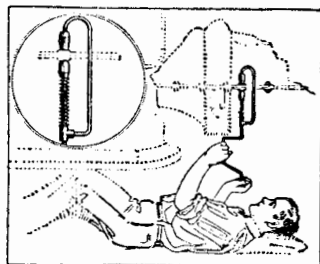

Our Reduced Price

H7200—"Speedy" Wrench (ship. wt., 3 lbs.) **1.38**

Steel Rules



Pocket rules of spring-tempered steel, with accurate, deep-cut, plainly marked graduations. **J7632** is graduated on all four corners, giving 8ths, 16ths, 32ds, and 64ths, also 32ds across end. **J7633** is graduated on two corners, 32ds and 64ths. Always handy, and indispensable for close, accurate work. Shipping weight, 4 oz.

J7632—Steel Rule, 6" long, 5/8" wide. **.55**

J7633—Steel Rule, 6" long, 1/8" wide. **.50**

Files—Best Quality Guaranteed



High quality files for general use around car and garage. Flat files useful in fitting piston rings, etc. Av. ship. wt., 8 oz.

Flat Files, H7331—6" **14** **H7332**—10", flat. **24**

Round Files, H7333—6" **14** **H7334**—10", round. **24**

3-Cornered File, H7335—6", extra slim taper. **14**

Clamp Vise

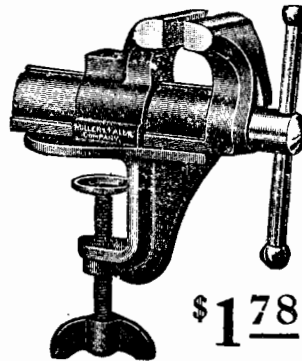

A very substantial, moderately priced vise—a tool every car owner should own. Steel jaws welded on; the head to the main screw is forged. A nut in the rear takes up all wear upon the screw, which prevents lost motion. Can be easily and quickly clamped to running board or work bench. Black enamel finish. Furnished with 2 and 3-inch jaws.

\$1.78

Our Reduced Price

H7482—2-inch Jaw (shipping weight, about 4 lbs.) **1.78**

H7483—3-inch Jaw (shipping weight, about 11 lbs.) **3.95**

Cylinder Head Gaskets

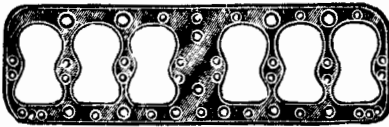

Highest quality gaskets of copper and asbestos. Well made and offered at an unusually low price. Average shipping weight, about 12 oz.

J7734—Ford, all models.....	.24
K8175—Overland 8 B, 85.....	.95
K8176—Overland 7.5B and 90.....	.64
K8177—Saxon 6, Moon, 1918-19, 6-36.....	.82
K8178—Dodge, all models.....	.36
K8179—Buick Light 4, D34, 35, 37, 1916-18.....	.65
K8180—Oldsmobile, 45, 46, 8-cyl., 1917-23.....	.75
K8181—Overland 85-6, 1916-19; Lexington Six, 1918-20; Liberty Six, 10B; Moon 6, 48-6-60, 1916-17; Velie 6, 1916-19.....	.85
K8182—Oakland 32B, 34B-D, all models; Oldsmobile 6, model 37-37A, 1918-20.....	.45
K8184—Chevrolet, all models, Oldsmobile, Economy Truck; Chevrolet 1-ton truck; Scripps-Booth Four, model G.....	.39
K8185—Overland Six, 82, 86, 88, 89, 1915-17; Westcott, 18; Velie Six 39; Moon 6-66; Case V-6.....	1.10
K8186—Hudson Super Six, 1914-23.....	.78
K8187—Grant Six, G and K, 1917-20; Velie 34.....	.68
K8188—Studebaker Big Six, Series 19-20-21, 1919-22.....	.88
K8189—Overland Four, 1920-23.....	.43
K8190—Studebaker Light Six, 1920-22, Series 20-21.....	.88
K8191—Maxwell 25, 1916-22.....	.88
K8192—Essex 1918-23.....	.88
K8193—Studebaker Special 6, 1919-22.....	.88
K8194—Star 1922-24.....	.88

Axle Shafts and Drive Shafts

For Popular Cars

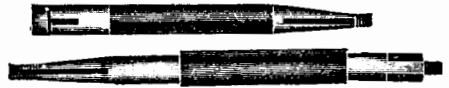

Our Axle Shafts are exact duplicates in size and shape of those used by the car manufacturer. Made of the very best grade special hot-rolled forged axle steel. Every axle is put thru a special heat-treating process, which greatly adds to its toughness, and is then ground to absolute accuracy to give a smooth running bearing service. Guaranteed as to fit, workmanship, and material. Average shipping weight, 10 lbs. Numbers marked * carried in stock at our stores, others shipped from factory in Kansas City.

Axle Shafts

2505—Ford 1909-23. Reg. 56-inch tread.....	*1.10
W8414—Buicks D, E, H, K-44-45-46-47.....	*1.20
W8416—Chevrolet 490.....	*1.20
W8432—Chevrolet Baby Grand, 1914-17.....	*1.20
W8433—Chevrolet Baby Grand, 1918-22.....	*1.20
W8417—Dodge 1916-21, straight center.....	*1.20
W8418—Dort, models 5-5A-6-8-9-10; C-11-29.....	*1.20
W8419—Grant 6, 1916-20, straight center.....	*1.20
W8434—Hudson Super-Six, 1917-22.....	*1.20
W8407—Hupmobile, Model R, 1917-22.....	*1.20
W8420—Maxwell 25, before 1920—Right.....	*1.20
W8421—Maxwell 25, before 1920—Left.....	*1.20
W8422—Maxwell 25, 1920-22, Right or Left same.....	*1.20
W8423—Overland 75, 90 Rds., 90 C. C.—Right.....	*1.20
W8424—Overland 75, 90 Rds., 90 C. C.—Left.....	*1.20
W8425—Overland 90 Tour—Right.....	*1.20
W8426—Overland 90 Tour—Left.....	*1.20
W8427—Overland 90B Tour (right or left same after serial 104,500).....	*1.20
W8428—Overland 4 1920-22—Right or Left.....	*1.20
W8435—Oakland 1917-1921.....	*1.20
W8436—Oldsmobile, 45A-45B, 8 cyl., 1920.....	*1.20
W8437—Oldsmobile, 37, 37A 6 cyl., 1918-20.....	*1.20
W8438—Reo 4 cyl. 1913-19 and 6 cyl., 1920.....	*1.20
W8429—Saxon Six, 1916-18, 30-inch.....	*1.20
W8430—Saxon Six, 1919-20, 31-inch.....	*1.20
W8431—Studebaker, 4 and 6 cyl., 14-18 (no flange).....	*1.20
W8408—Studebaker, Four, 1919, and Light 6, 1919-21.....	*1.20
W8411—Studebaker, Big 6, 19-22 and Special 6, '20.....	*1.20

Drive Shafts

2595B—Drive Shaft for Ford.....	*1.88
W8444—Chevrolet 490 Drive Shaft.....	*1.88
W8445—Dodge Drive Shaft 1917-22, (57 1/8 in long).....	*1.88
W8412—Maxwell Drive Shaft, 1915-17, 54 1/2 inch.....	*1.88
W8413—Maxwell Drive Shaft, 1918-19, 58 1/2 inch.....	*1.88
W8439—Maxwell Drive Shaft, 1920-22.....	*1.70

If your car is not shown here, write us for price, giving make of car and model, and state if for right or left side. We save you 20% to 50%.

Gear Shift Extensions for Popular Cars.

On many cars the gear shift lever is too short, making the shifting of gears inconvenient. It is very unhandy to reach down to a lever which is so low it causes you to bend over. This extension attaches to the top of lever and extends up a few inches, placing the round knob handle just in the right place. Be sure to give make of car when ordering. Shipping weight, 1 lb.

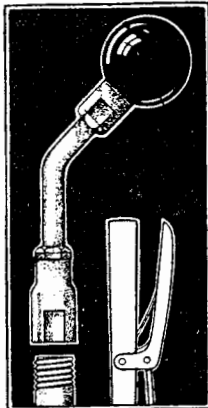

K8201—For Buicks 1917-22, Buick 1924, Chevrolet 1923-24, Maxwell 1916-19, Oakland 1921-22.....	1.40
K8205—Buick 1923.....	1.40
K8202—Dodge before 1922, Dodge 1924, Nash, Overland 75, 90 and 4, Willys-Knight '21-22.....	1.20
K8219—Dodge 1922-23, Lincoln all models.....	.20
K8203—Studebaker (except Little 6).....	1.40
K8221—Studebaker Little Six all models.....	1.40
K8204—Cleveland, Dort, Elgin, Gardner, Monroe, Stephens Six before 1923.....	1.40
K8206—Cadillac, Chalmers 1919-20; Cleveland 1923; Dort 1923; Lafayette, Stephens 1923.....	1.40
K8207—Allen, Buick 1914, 15, 16.....	1.40
K8208—Columbia 1919-20, Grant, King 1917-19, Liberty Six 1917-19, Maxwell 1921, also 1923, Patterson,.....	1.40
K8209—Case 1919-20, Chandler 1916-19, Dixie Flyer, Elcar, Haynes 1920, Interstate, Roamer, Tulsa.....	1.40
K8210—Chalmers 1924; GMC Truck, Jordan 1918-21, Kissel 6, Master Truck, Republic Truck.....	1.40
K8212—Chalmers 1922, Overland with solid ball; Stutz, Willys-Knight before 1921.....	1.85
K8213—Essex up to 22, Hudson 1920 Super Six.....	1.40
K8214—Briscoe, Oldsmobile except 8-cyl.....	1.40
K8216—Chandler 1920-22, Chevrolet 1919-22, Durant, Oakland Sedan 1920, Oldsmobile 43-45-46, 8-cyl.....	1.40
K8217—Apperson, Columbia 1921-22, Hupmobile 1918-22, King 1920, Moon 1919-22, Peerless, Revere, Velie.....	1.40
K8218—Cole, Dorris, Kissel Sport Model, Lexington 1918-22, Packard 1921-22 and Single Six.....	1.40

Gas Tank Caps for Popular Cars



Attractive caps, finely nickel-plated on highest grade of bronze. Easy to handle. Fully guaranteed. Will fit cars as listed below. In ordering be sure to give year and model of car. Shipping weight, 1 lb.

D6280—Gas Tank Cap for Nash.....	.78
D6281—For Auburn, Columbia, Dort, Essex, Grant, Jordan, Templer, Velie, Winton.....	.78
D6282—For Chevrolet 490 and Baby Grand, Elgin, Holmes, Liberty.....	.78
D6283—For all Reo cars.....	.78
D6284—For Chandler, Cleveland, Crow-Elkhart, Commonwealth, Hupmobile, Moon, Oakland, Stephens, Scripps-Booth.....	.78
D6285—For Allen, Dodge, Kissel, Paterson.....	.78
D6286—For Franklin, Friend, King, Kline, Maxwell, Studebaker Light 6.....	.78
D6287—For Haynes, Lexington, Mitchell.....	.78
D6288—For Anderson, Cole, Hanson, Hatfield, Studebaker Big 6 and Special 6.....	.78
D6289—For Hudson, Oldsmobile.....	.78
D6290—For Paige, Stearns.....	.78
D6291—For Buick, 1915-22.....	.78
D6292—For Chalmers.....	.78

Visible Gasoline Gauge

FOR CHEVROLET CARS WITH TANK IN REAR

Eliminates all guessing as to how much gas you have, how much you need, and whether you actually get what you pay for. Screws into tank in place of the regular filler cap. Cap is die-cast aluminum, beautifully finished, with polished etched dial and glass enclosed face. Tube is rolled brass—rust proof. Enclosed float mechanism insures accuracy. Heavy cork gasket prevents leakage of gas around cap. Nothing to get out of order; will last indefinitely. **Will not fit roadster or utility coupe.**

G7049—Each (ship. wt., 3 lbs.)... **1.48**



Clutch Collar Oiler for Chevrolet "490" and "Superior"

The bronze clutch collar on a Chevrolet works perfectly when its reservoir is filled with oil, but it is easy to neglect it, because of the necessity of taking up the floor boards, and then there is trouble.

This new oiler fastens on the inlet pipe, under the hood, and provides an easy way of oiling the clutch collar. Simply fill up the oiler when putting oil in the crank case, and it takes care of itself. Strong, simple and substantial. Saves squeaking, rattling, and repair bills. Easily installed in 10 minutes; will last as long as the car. Regular price, \$1.50. Shipping weight, 1 lb.

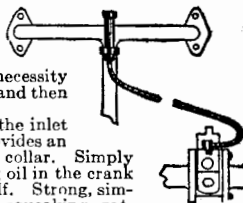

J7808—Complete with instructions..... **.95**

Hood Clips for Chevrolet 490 Cars



Every Chevrolet 490 owner knows what a slow and hard task it is to raise the hood on his car and to keep it closed tightly so that it will not rattle. Here is a spring clip that solves both problems. Can be installed in one minute without the use of tools by removing the thumb screws which are on the car now and attaching this clip to the bolt on the old one. Will never slip and rattle and will outlast the car. Adjustable to any tension. Comes complete ready to put on. Ship. wt., 1 lb.

K8027—Complete Set..... **.78**

Gear Shift Anti-Rattler For Chevrolets

Chevrolet owners know how annoying is that constant rattle of the gear shift lever that persists no matter how much it is tightened. This little inexpensive anti-rattler that only takes a minute to put on, is a permanent remedy for the rattle and noise of the lever. Ship. wt., 4 oz.

Our Reduced Price
K8199—Anti Rattler, complete.... **.49**

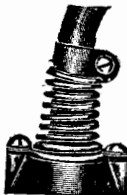

Valve Cover for Chevrolet Motor Less Noise, Less Wear

A high quality metal cover for Chevrolet engine head. Keeps dust and grit out of valve mechanism, thus reducing wear, and also greatly lessens the noise made by the valves in operation. Is lined on top with heavy felt pad, 3/8 in. thick, which when soaked in oil will keep valves well oiled for 500 miles of driving. Shipping weight, 5 lbs.

X8862—Valve Cover, Complete..... **1.18**

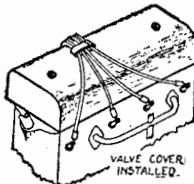

Noiseless Push Rods for Ford and Chevrolet 490

Take the place of the regular push rods or valve lifters on Ford and Chevrolet cars. Consist of a plunger that works in the push rod tappet stem and is held in place in the stem by a spring that absorbs the shock of the cam's eccentric motion, and gives a sliding action, instead of a hammer-like blow. Absolutely eliminates valve tapping noises and the "clicking" that is so noticeable in Ford and Chevrolet cars. Causes less vibration, gives greater mileage through better valve seating, and much less valve grinding. Just as easy to put in as a set of the regular type and will last as long as your car. Ship. wt. per set, 2 lbs.

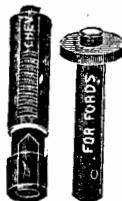

K8038—Complete set for Ford..... **2.95**
K8039—Complete set for Chevrolet 490..... **2.95**

Leather-Tex Clutch Facing FOR CHEVROLET 490 AND SUPERIOR

Leather-Tex is a combination of leather and textile, merged into one compact unit by tremendous hydraulic pressure. The textile backing next to the clutch cone gives the resiliency necessary for an easy, smooth-working clutch, while the leather face will withstand the strain of hard usage under the most severe conditions. Fits Chevrolet 490, Oakland, Oldsmobile 6 and Scripps-Booth.

B5346—Each, ready to put on (ship. wt., 1 lb.)..... **.95**



Rear Axle and Drive Shaft Bearings FOR CHEVROLET 490 AND SUPERIOR

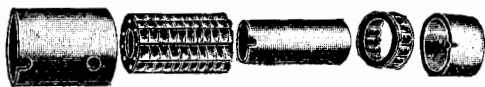

Genuine Hyatt bearings and sleeves, same as are used as standard equipment. Average shipping weight, 1 lb.

H7255—Drive shaft roller bearing.....	1.85
H7256—Drive shaft roller-bearing sleeve.....	1.25
H7257—Drive shaft sleeve.....	2.95
H7258—Rear axle outer roller bearing.....	4.45
H7259—Rear axle outer roller-bearing sleeve..	4.55

Drain Cock Wrench for Chevrolet

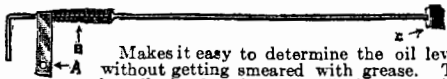

Makes it easy to determine the oil level without getting smeared with grease. To install, simply slip Socket "C" over drain-cock handle, and put the lower intake manifold bolt through the hole "A." Spring "B" holds device securely and prevents rattling.

J7775—Each (ship. wt., 1 lb.)..... **4.55**

Hub Cap For Chevrolet 490

Substantial, nickel-plated hub cap for Chevrolet 490. (will not fit Superior).

H258—Each (ship. wt., 4 oz.)..... **.23**



Support for Chevrolet 490 Motors

Almost every Chevrolet owner has at some time experienced clutch trouble. Perhaps the clutch slips and burns out the clutch faces; perhaps it grabs and takes hold all at once, throwing a heavy strain on every moving part of the car. The cause of this is that the clutch does not engage truly and evenly. Generally the rear end of the motor, due to wearing of bolts and bolt holes and the springing of the supporting arms, has sagged so that the clutch and fly-wheel are out of alignment and do not engage properly. Our support will draw the clutch and fly-wheel back into proper alignment and will hold them there for the life of the car. No holes to drill, no tools to buy. All necessary new bolts furnished. Interferes in no way and does not prevent removal of oil pan and adjustment of bearings. Absolutely guaranteed. Shipping weight, 16 lbs.

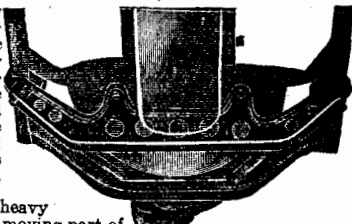

W8341—Support complete..... **4.65**

Dyke's Auto Encyclopedia

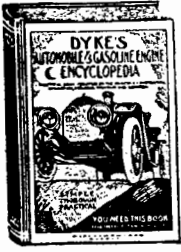

The new 13th edition, entirely rewritten, rearranged, illustrated and enlarged. Mr. Dyke devoted nearly all of his time for two years to re-writing this new edition. 1238 pages, 1433 illustrations.

A practical book for the repairman, auto owner or student. Teaches the fundamental principles of each and every part of an automobile, mechanical or electrical. Large clear type, plain simple language. Easy to read, easy to understand.

Tells just what you want to know about Car Assembly, Motors, Carburetion, Cooling and Lubrication, Ignition and Lighting Systems, Batteries, Troubles and Repairs, Trucks and Tractors, Aeroplane Engines, and has 69 pages with 239 illustrations on the construction, upkeep and repair of Ford cars. A valuable reference book and a practical automobile education. Publisher's price, \$6.00.
A5088—Dyke's Encyclopedia (ship. wt., 6 lbs.)... 4.95

Ignition and Lighting Systems, Batteries, Troubles and Repairs, Trucks and Tractors, Aeroplane Engines, and has 69 pages with 239 illustrations on the construction, upkeep and repair of Ford cars. A valuable reference book and a practical automobile education. Publisher's price, \$6.00.

Instruction Book for Ford Cars

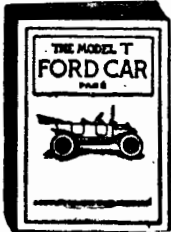

Construction, Operation and Repair. Latest Edition.

A high-grade, cloth-bound book, printed on the best paper, illustrated by specially made drawings and photographs. All parts of the Ford Model T Car are described and illustrated in a comprehensive manner. The construction is fully treated and operating principles made clear. Complete instructions for driving and repairing are given. The new edition contains 310 pages, 106 illustrations, two large folding plates, including the Ford Starter, the Fordson Tractor and One-Ton Truck. Learn to take care of your car—save time and money.

Shipping weight, about 2 lbs. Publisher's price, \$2.00.
A5085—Our Reduced Price 1.58

Ford Owner Magazine

The popular monthly magazine devoted exclusively to current news, helpful suggestions and practical ideas on the proper care and repair of Ford Cars and Tractors. Handsomely illustrated. Mailed every month. Contains from 64 to 176 pages, size 6 1/4 x 10 inches. 32-page book on "Ford Care and Home Repairs" free with each subscription. This book alone may be worth the whole subscription to you. Mailed, prepaid for one year... **1.50**

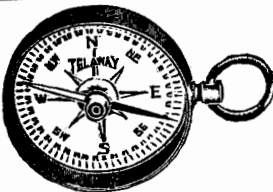

Pocket Compass

A great convenience on any trip; almost indispensable when touring. Well made, reliable. Diameter 1 1/2 inches. Has ring for attaching to watch chain. Ship. wt., 4 oz.
C5761—Each... .65

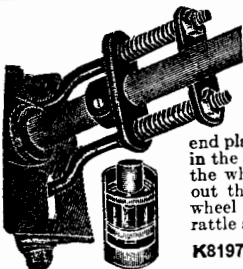

Chevrolet Steering Gear Anti-Vibrator

Fits all Chevrolet 490 cars (except 1916 model) and stops the vibration, clatter and noise caused by end play of the steering wheel shaft in the steering gear case. Steadies the whole steering gear and takes out that looseness in the steering wheel by eliminating the side slap rattle and end play of the shaft.

K8197—Each (wt., 4 oz.) 1.85

"Take-up" Bushing

Used in connection with above, it replaces bushing at top or bottom of steering wheel column and has adjustable "take-up" for any wear.

K8191—Take-up Bushing, each (ship. wt., 4 oz.) 1.10
X8816—Set one each K8191 and K8197..... 2.35

Automobile Blue Book



Will tell you how to reach any place that can be reached by automobile. Gives detailed running directions for every mile; tells how far to any place and general conditions of roads; where to stop; where to eat; where to get gasoline, supplies or repairs; where service stations are; what speed laws and traffic laws to observe; points out the historic and scenic places along the way; warns of grades and curves and dangerous crossings; tells you just where you are at any minute of your trip. It will save time and money, as well as taking the uncertainty and worry out of your trip. Furnished in genuine flexible leather binding, with new transparent map holder which makes it easy to compare map and route. Size, about 5 1/4 x 9 1/4. Latest edition. Ship. wt., each, 3 lbs.

- A5111—Showing routes in New York and New England, (Vol. 1) 2.68**
- A5113—Showing routes in Penn., N. J., Md., Va., Tenn., N. Car., S. Car., Ga., Fla., Ala. and Miss. (Vol. 2) 2.68**
- A5117—Showing routes in Mich., Ohio, Ky., Ind., Ill., Mo., Ia., Wis. and Minn. (Vol. 3) 2.68**
- A5118—Showing routes in N. and S. Dak., Neb., Kans., Okla., Tex. and all states west, including Colo. and Calif., with main transcontinental routes to the Atlantic Coast. (Vol. 4) 2.68**

Rand-McNally Auto Trails Maps



A series of maps for automobile tourists, complete in every detail, convenient in size and thoroughly up-to-date. The marked automobile routes are featured with explanation of the markers. The motorist selects his route from the map, familiarizes himself with the style of marking on the poles along the route and then follows the markers. He is assured of reaching his destination over the best and shortest road. City maps are included, which show the routes through principal cities; also lists of the better garages, hotels and service stations. Shipping weight, 4 oz.

- J7920—Wisconsin.....**
- J7922—Iowa.....**
- J7925—Idaho, Montana and Wyoming.....**
- J7926—Washington, Oregon and Brit. Col.....**
- J7927—California and Nevada.....**
- J7929—Colo., N. Mex., Ariz. and Utah.....**
- J7930—Texas and Oklahoma.....**
- J7857—Florida, Georgia and Alabama.....**
- J7858—Illinois and City of Chicago.....**
- J7859—Indiana, Kentucky and Tennessee.....**
- J7860—Minnesota, N. Dak., and S. Dak.....**
- J7861—Missouri, Arkansas, Louisiana & Miss.....**
- J7862—Nebraska and Kansas.....**
- J7863—N. Car., S. Car., Md., Va. and W. Va.....**

TIB Automobile Route Books



These well-known road guides give complete and detailed road information. You cannot get lost with TIB—a complete picture of the road is always before you. A speedometer is not necessary for the successful following of TIB maps. Printed on heavy paper in a convenient pocket size. Completely revised and up-to-date; the best edition yet. Shipping weight, 4 oz.

- B5400—Wisconsin and Michigan (Vol. 2).....**
- B5401—Minnesota (Vol. 3).....**
- B5402—Iowa and Nebraska (Vol. 4).....**
- B5403—Dakotas and N. W. Pac. Coast (Vol. 5).....**
- B5404—Missouri and Kansas (Vol. 7).....**
- B5405—Oklahoma and Texas (Vol. 9).....**
- B5406—Colorado and California (Vol. 10).....**
- B5407—Illinois, Indiana, Atl. Coast (Vol. 1).....**

Folding Luggage Carrier

For Running Board of Any Car

\$1.05

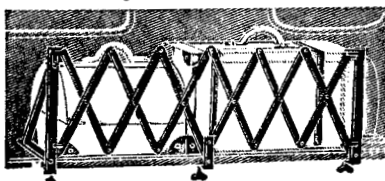

A new adjustable carrying outfit that can be attached to the running board of any car. Clamps on securely by three thumb screws. Easy to put on or take off. Folds up compactly when not in use. Made of steel, strong and durable. No more piling stuff around on the seats or holding packages when car is full of passengers. Just the thing for farmers when going to or coming from town.



Indispensable for camping or touring. Nothing to break or get out of order; will not rattle. Adjustable to a length of 10 to 60 inches, so that you can easily carry unusual sized packages. Size folded, 19x11½x23¼. Durable black enamel finish. Shipping weight, about 11 lbs.

A5178—Carrier as illustrated. **1.05**

J7811—Same style folding carrier, extra quality; made of cold rolled steel; center side brace attaches half-way up carrier where uprights cross, so it will support a heavy load without sagging out; adjustable to 66 inches; shipping weight, 12 lbs. (not illustrated). **1.78**

Rear Trunk Rack for Ford and Chevrolet Touring Cars

Illustration shows new all-steel trunk rack for use on Ford and Chevrolet touring cars having spare tire carriers. Arms fasten to top rest and body of rack is attached to tire carrier with clamps furnished. Has license and lamp bracket and folds against spare tire carrier when not in use. Black enamel finish. Inside dimensions 15 in. by 32½ in. Complete with all attachments. Shipping weight, 15 lbs.

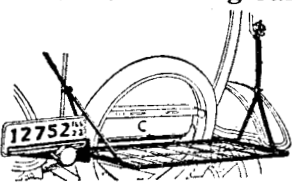

A5176—For use on Chevrolet 490 and Ford Touring, with rear tire carrier. **3.55**

A5175—Special Trunk Rack for use on Ford Touring cars only, when not equipped with tire carrier, shipping weight 16 lbs. **2.85**

Steel Tent Stakes

Made of ½-in. Bessemer steel, 10 in. long. Sharpened point, top properly bent. Strongest and most convenient tent stake made; can be used regardless of the condition of the ground.



K8100—Each, (Ship. wt., 1 lb.) **.14**

Jointed Tent Poles

Jointed 3 foot sections, easily carried. Select grain wood, with strong metal flange at joint. Well finished and strong yet light in weight. Ship. wt., 2 lbs.



X8528—Round Tent pole, complete, (2 pieces) **.48**

Auto Spade

The Auto Spade comes in handy when you get stuck in the mud or sand. Can also be used as base for jack in soft places. Entire length, 28½ inches. Has detachable handle, enabling you to put it in tool box or under rear seat. Size of blade, 6 in. wide, 9 in. long.



D6271—Our Reduced Price. (ship. wt. 3 lbs.) **1.78**

Disappearing Luggage Carrier

Folds down on the edge of the running board when not in use. Lets you

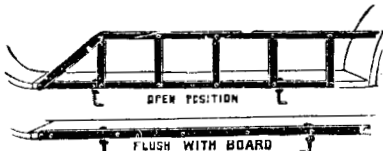

keep the carrier always on the car for use at any time, without being in the way. Clamps securely on the running-board. Strong and substantial, yet light in weight. Length 42 in., height 10 in. Especially desirable for use on closed cars because it does not prevent the doors from swinging freely above it. Nicely finished in black enamel. Shipping weight, 10 lbs.

W8383—Our Reduced Price **1.19**

Carrimore Luggage Rack FOR FORD CARS ONLY



Clamps firmly between fenders, making entire running-board and fender area available for

carrying luggage. Also acts as brace to hold fenders in place. Top bar is of angle steel for strength and stiffness. Thumb nuts lock it in place on fenders. Does not interfere with opening of doors. Finished in black enamel, baked on. Fits any model Ford. Can not be sent by mail.

W8446—Complete (ship. wt., 9 lbs.) **1.25**

Automobile Covers

It doesn't pay to leave your car exposed to the weather, even on a short trip. Take an auto cover along, and protect car and upholstery from dust, rain and dew. Can be stretched out to one side of car and made to serve as a tent. Made from substantial white drill, with necessary tie ropes, etc.

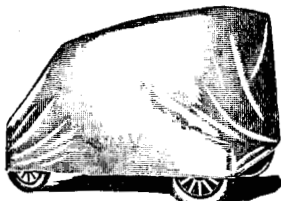

Average shipping weight, 16 lbs.

X8690—Size 14x18 (for Ford and small cars). **10.95**

X8691—Size 16x24 (for larger cars) **17.65**

No Water Hand Soap

Lets you clean your hands after tire or engine repairs without use of water. Removes grease, dirt and even dye-stains better than ordinary soap. Will not chap the skin or injure the most delicate fabric. Packed in close-sealing can; carry one in your tool box and be prepared. Shipping weight, 1 lb.



A5159—Our Reduced Price

Camp Axes

A very handy article to take with you on that camping trip. Made of best grade steel, handle of selected hickory. Has nickel plated guard and receiver. Weight, 1 lb. Length, 10½ inches.



K8102—Axe with metal guard. **1.95**

K8133—Extra Quality Axe with Leather Sheath **1.12**

Handy All-Steel Auto Shovel

Blade and handle are forged from a single piece of bar steel, making a shovel that will stand all sorts of hard usage. Blade is 6x8 inches, with sharp beveled cutting edge; handle 16 inches, making total length 24 inches, easily carried under the seat. Useful in many ways on trip, in camp or around the yard at home.



E6415—Each (ship. wt., 2 lbs.) **.58**

Western Special Tent

Waterproof Khaki Top -

SPECIAL \$1295

Through a fortunate contract we are able to give one of the greatest tent values ever offered. This popular style auto touring tent has top made of 12-oz. Khaki duck, chemically treated, making it absolutely water-proof; sides and flap which fasten over car are 10-oz. white water-proof duck. Tent can be entered at side as well as front. Outside corners are laced, permitting walls to be raised for ventilation. Has pocket in side, also ample loops for hanging clothing. Strong and durable; folds into small space. Size: 7 x 7 ft., height 6 ft., wall in rear, 3 ft. Comes complete with necessary stakes and ropes. Shipping weight, 26 lbs.

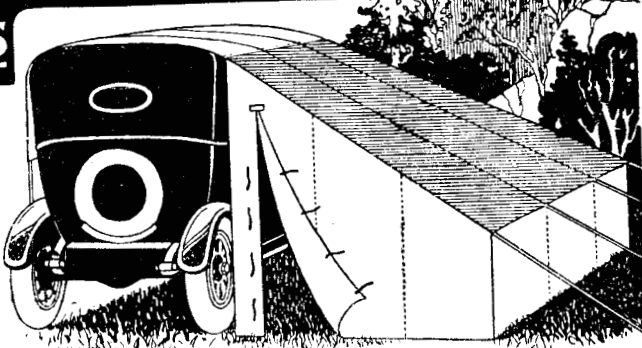

- | | | | |
|------------------------------|--------------|---|-------------|
| X8529—Western Special tent | 12.95 | X8518—Water-proofed canvas floor for tent (ship. wt., 8 lbs.) | 4.85 |
| X8521—Same, except all khaki | 15.95 | X8519—Canvas curtain to drop between tent and car | 3.65 |

“Camper’s Delight” Auto Tent

The “Camper’s Delight” Auto Tent is designed to give the user a real house to live in when traveling. It is especially arranged for convenience, is quickly rolled up and takes but little space. The front next the car can be closed by bringing together two canvas curtains that meet in the center and extend under the canvas floor, making it impossible for anything to crawl into the tent. Top of tent extends well down over opposite side of car, keeping everything dry in case of rain. This extension makes a handy porch when car is removed. Extra well-made. Top is 12-oz. water-proofed Khaki Army Duck. The walls, floor and curtain are made of heavy white drill, which is water-proof and very durable. Made with pockets and window. Size of tent, 8½ x 7 feet. Neat carry-all bag is furnished; also ropes, stakes and two jointed poles. Shipping wt., 49 lbs

- | | |
|-----------------------------------|--------------|
| X8693—Camper’s Delight Auto Tent | 26.95 |
| X8694—Camper’s Delight, all khaki | 32.65 |

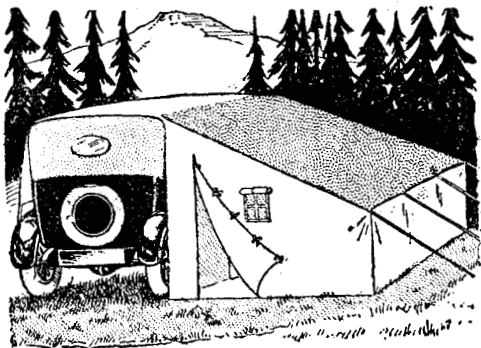

Leader Auto Tent

Another unusual tent value. An all-khaki tent, size 7x7 feet, with 2½-foot wall. Side-walls and awning of 10-oz. khaki drill, top of heavy 10-oz. awning duck, treated with khaki-colored waterproof solution. Guaranteed both water-proof and mildew-proof. Comes complete with guy ropes and tent pins, all packed compactly in a burlap carrying bag. Awning extends well down on opposite side of car. A roomy, practical tent for camping or touring trip; easily set up or taken down; easily carried. Shipping weight, about 22 lbs.

- | | |
|---|--------------|
| X8524—Leader Auto Tent | 10.95 |
| X8518—Water-proofed canvas floor for tent (ship. wt., 8 lbs.) | 4.85 |
| X8519—Canvas curtain to drop between tent and car (ship. wt., 5 lbs.) | 3.65 |



WALL TENTS

Well-made, high-quality wall tents of regulation design, with 8-foot walls. Made of standard grade 10-oz. white duck. Practical, roomy, easily put up and taken down; very solid and substantial. Come complete with all necessary poles, ropes and stakes, which are included in shipping weights shown.

We carry in stock only the four sizes listed, but can supply on short notice any other size or style you may desire. Prices gladly furnished on request.

We do not furnish tents made of 8-oz. material, as experience has shown that these are entirely too light, and will not give satisfactory service.

- | | |
|--|--------------|
| X8547—Size 7 x 7 ft., 10-oz. duck (wt., 32 lbs.) | 12.95 |
| X8548—Size 8x10 ft., 10-oz. duck (wt., 43 lbs.) | 16.95 |
| X8549—Size 10x12 ft., 10-oz. duck (wt., 54 lbs.) | 21.95 |
| X8551—Size 12x14 ft., 10-oz. duck (wt., 65 lbs.) | 28.95 |

Ever-Ready Folding Camp Stove

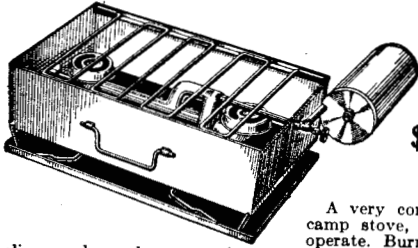

\$4.95

A very convenient camp stove, easy to operate. Burns gasoline and produces an intensely hot flame without smoke or soot. Each burner can be regulated to low or high flame as desired. It is only necessary to generate one burner, as this produces gas for other burner, which may be turned on or off at will. No flying sparks or ashes. No fuel to search for. Safe and convenient. Always ready for use. Folds up compactly into steel case about 17 1/2 x 10 1/2 x 4 1/2 inches, which has carrying handle. Ship. wt. 10 lbs.

A5219—Stove complete—2-burner **4.95**
X8533—Special 3-burner size, 26x11x3 1/2.
 Shipping weight 16 lbs. **11.65**

Folding Camp Grate



A necessity for the tourist; a joy for camping. No more upset coffee pots or skillets; no more burned fingers. Nothing adds so much pleasure, or health, to your motor trips as the out-of-door camp-fire. Just the thing for broiling or "Weenie Roasts." Durably made of steel. Easy to set up; folds up when not in use. Can be carried under the seat or in lunch basket. Ship. wt., 3 lbs.

A5170—Size 13 1/2 x 21 1/2 in.—Our Reduced Price **.78**

Folding Skillets and Pans



A skillet is needed on every camping trip or picnic. The trouble with the regular style is that they take up too much room and are difficult to pack. The folding type collapses as shown above, making a flat package easily carried.

K8114—7 1/4 in. diameter by 1 1/2 deep, (wt. 2 1/2 lb.) . **.45**
K8115—10 in. diameter by 2 in. deep, (wt. 3 lb.) . **.65**

Favorite Tow Rope



A light-weight, but exceptionally strong tow rope for general use. Made of high-grade Manila fiber, with flexible steel wires interwoven, running the full length, making it amply strong for all ordinary towing. Has a substantial hook at each end.

K8109—Each (ship wt., 4 lbs.) **1.15**

Ever-Klean Folding Seat Mats

Cool, Clean and Sanitary

Keep seats and cushions of your car clean and free from dust. Prevent clothing from sticking to the seat.

Made of finest select flexible woven matting, specially treated to retain life, durability and flexibility. When not in use, can be rolled up and carried in door pocket. Edges are well bound, and a wide hinge of strong khaki cloth makes the Ever-Klean mats fit perfectly in any make of automobile without breaking the straw. Woven in mixed colors, guaranteed not to fade.

Furnished in three styles. The De Luxe, shown at right, has back and seat each 18 1/2 x 18 1/2 inches, with front flap over cushion riser 7 1/2 x 18 1/2 inches. Entire reverse side is lined with strong khaki cloth, and binding on edge is reinforced with leatherette.

The Standard style, not illustrated, is the same as the De Luxe, except without the front flap. Reverse side is lined, and edges reinforced with leatherette.

The Handy style, shown at left, has seat and back each 17 x 17 inches. It is not lined on reverse side, and has no

Our Special Folding Camp Table



\$3.65

One of the handiest folding tables on the market. Especially designed to give strength, compactness and light weight. Made of selected high grade wood. Legs have steel reinforced joints, rigid and strong enough to support 300 lbs. Size of top: 3 feet by 2 1/2 feet. Folds into very compact bundle 3 feet long by 5 x 7 inches. Just the thing for picnics or touring and camping trips. Ship. wt., 18 lbs. **Our Reduced Price**

X8546—Complete **3.65**

Auto Lunch Kit

An ideal kit for touring, camping and picnics. 15 pieces of triple-coated white enameled ware—six 8" plates, six 3/4 pint cups, two 6 3/4" bowls, 1 4 quart seamless pail. All articles fit snugly inside the pail, being held securely by special locking arrangement. Durable and sanitary; takes up little space; always ready for use. Shipping weight, 8 lbs.



X8564—Our Reduced Price, complete **4.35**

Auto Tow Rope



Every car going on a touring trip should carry a tow rope. While they are not needed very often, yet when you do need one, you "need it bad." Our rope is 20 feet long, 3/4" diameter, made of

extra quality Manila rope, with sliced loop in each end and hickory plug attached for hitching. No knots to tie. No knots to untie. Strong enough for towing any car. Neatly packed in substantial bag. Shipping weight, 5 lbs. **K8110**—Manila Auto Tow Rope **1.48**

All-Metal Folding Auto Stool

A substantial, all-metal seat that folds up so compactly that it can be carried in the coat pocket; size folded, 6" wide, 12" long, 1" thick. Set up in 30 seconds into a comfortable seat, 6" x 15", 16" high. Weighs less than 2 lbs. Fine for use as extra seat in car, at picnics, ball games, etc. Regular price, \$1.50.

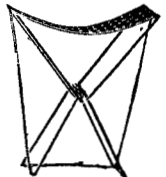

A5179—Our Reduced Price **1.10**

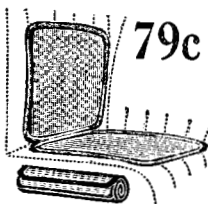

79c

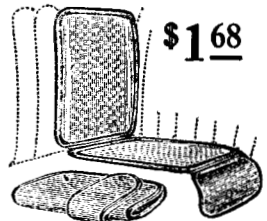

\$1.68

leatherette on edges. It is strong, serviceable and well-bound, and is reversible for use on either side.

Ever-Klean mats have hundreds of uses around the house, camp and car. They are convenient to carry for use on picnics, at ball games, boating, etc., for comfort and protection to clothing. Shipping weight, 2 lbs.

D6275—"Handy" style, straw both sides **1.78**
D6274—"Standard," lined on back **1.68**
D6273—"De Luxe," lined, with front flap **1.68**

CARSON AUTO BED—For All Cars

At last we have found a real auto bed that is not weak and flimsy but strong and substantial and at the same time is light and can be packed in a compact bundle. Made of highest quality gum slats, held together with strong webbing. Lies on the backs of the seats and cannot slip as one end rests against the back stays and the other against the steering wheel. Will easily accommodate two grown persons and a child and will not sag. Rolls up and fastens on side of car as shown in the illustration. Just the bed you have been looking for to use on that trip. Shipping weight, 19 lbs.

X8523—Carson Bed for Ford cars, without bag..... **8.65**
X8512—Bed for larger cars, without bag..... **10.35**
X8526—Waterproof Bag for carrying either of above as shown in illustration (weight, 2 lbs.)..... **1.95**



Utility Folding Steel Bed Ideal for Camp or Sleeping Porch

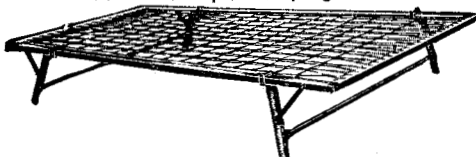

A strong, substantial, comfortable bed for touring, that also comes in handy all the year 'round for the sleeping porch or unexpected guest. Makes a bed 4 feet wide and 6 feet 6 inches long, quickly folded into a bundle only 5x6x48 inches, that slips into a heavy 12-oz. bag. Has strong, sagless springs made of rustless coppered spring steel. Insures a good night's rest after an all-day's drive. Shipping weight, 48 lbs.

Our Reduced Price
X8696—Folding steel bed, complete with bag... **15.65**

"Jiffy" Folding Camp Bed

A one-piece bed without braces that is light in weight, but strong and substantial. The lightest durable bed on the market. Has strong, constructed steel frame, heavy olive-drab canvas top, reinforced with 2-inch heavy webbing; 19 steel coil springs at head of bed, eliminating all "roll to center." Has take-up arrangement to cover any slack that may develop. Full size, 4 feet x 6 feet 3 inches. Folds into bundle 2 1/2 x 7 x 48 inches, with straps attached for fastening bundle. Quickly and easily put up or taken down.

X8562—Jiffy bed, complete (Ship. wt., 40 lbs.)... **15.85**

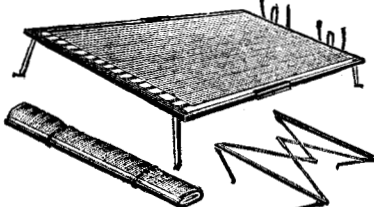

Extra Quality Folding Camp Cot Strong and Substantial, Yet Light in Weight

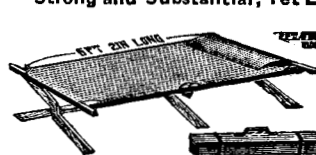

The cot shown is the most popular of all folding cots on the market to-day. Frame is made of strong, light material, and covering is heavy brown duck. Makes a full-length, easy, elastic and

comfortable bed. When folded, makes a snug package only 3 feet long and weighing only 18 lbs. Easily set up or taken down. Strong enough to support 1000 lbs.

W8362—Each, (Ship. wt., 18 lbs.)..... **3.85**

Folding Steel Chairs and Stools For Use in Auto or Camp

Unusually strong and compact. Will hold up 500 pounds or more without strain, yet when folded they occupy a space of only 18x11x11 inches.

Frame is constructed of flat steel, furnished in durable black baked Japan. Back and seat are made of heavy khaki duck, lock-stitched. Strong supports and braces prevent wobbling.

Fine for use in camp or picnic. Make a comfortable extra seat in automobile.



Ship. wt., 51 lbs.
A5168—Folding chair with back rest (as shown). **1.78**
A5169—Folding stool without back rest..... **1.18**

Folding Camp Stool

A sturdy folding camp stool for touring and picnics. Frame made of strong wood, reinforced at joints with steel. Seat of strong canvas. Shipping weight 4 lbs.

E6535—Price, each..... **.78**



GENUINE LEE UNION-ALLS

Every man who owns a motor car should have a pair of Lee Union-alls. They are nationally recognized as the coolest, most comfortable and most practical work garments ever made. Save your clothes, save cleaning and laundry bills. Made in one piece, fit perfectly all over, will not bind or rip, triple stitched throughout, reinforced at all points of strain, plenty of handy pockets, with rust-proof buttons that are guaranteed not to pull off.

Made of heavy-texture, high-grade khaki, a color that does not soil easily, and can be washed without injury to material or fit. Furnished in two grades, as listed below. For hard service, day in and day out, the better grade is well worth the difference in price. For occasional use in "tinkering" around the car, the lower-priced ones are very popular. These grades are practically the same in style and workmanship—the only difference is in weight of material.

Any Unionall will shrink some when washed. We suggest ordering one size larger than regular. Give chest measure and state if short, medium or long for size. Average shipping weight, 5 lbs. Samples of material on request.

Regular Grade—Factory Number 252

- K8085**—Men's, sizes 34 to 44.....
- K8086**—Youth's, 12 to 16 years.....
- K8087**—Boys', 8 to 11 years.....
- K8083**—Lee Union-alls for children, 1 to 7 years (give age), pair.....

Extra Quality Union-alls, for Harder Service—Factory Number 202

- K8080**—Men's, sizes 34 to 44, short, medium or long.....
- K8081**—Youths', 12 to 16 years (Ship weight, 41 lbs.).....
- K8082**—Boys', 7 to 11 years (Ship weight, 3 1/2 lbs.).....
- K8084**—Ladies' Union-alls (drop seat, sport neck), per pair.....

For sizes 44 to 50 add 10% to price.



UNION-ALLS
 MADE
 IN
 U.S.A.

Genuine "Franco" Flashlights



98c
AND UP



"Franco" flashlights are nationally known as one of the best made. In fact, their patented case construction puts them in a class by themselves. This case is made of highest quality fibre, with the brass connecting strip imbedded in the fibre, away from all possible troubles of breakage, corrosion, short-circuit, or wear and tear. They will last twice as long as any other fibre case.

The sizes listed below are the best for all-around use—not too small, yet large enough for most economical use. Standard sizes for which you can secure new batteries anywhere when the old ones wear out. Furnished with the famous single-cell flashlight battery, two of them being used in a 6½-inch flashlight and three in a 9-inch. If one of your cells is weak or gets broken, it is not necessary to buy a complete new battery, as you can replace the weak cell. "Franco" mono-cells are guaranteed to give from 12 to 16 hours of service, whereas most other batteries give only 8 to 10 hours.

Each flashlight comes complete with bulb and batteries ready for use. Average shipping weight, 1¼ lbs.

- 98c**
- 1.18**
- 1.20**
- 1.38**
- 1.48**
- 1.78**
- 1.98**
- 1.13**
- 1.12**
- 1.15**
- 1.20**

De Luxe Aluminum Thermal Jug

Absolutely Guaranteed Against Breakage

This is the most serviceable and substantial thermal jug we have ever seen. Has a heavy metal jacket of 20-gauge polished aluminum. Equipped with a heavy Bristolware filler, glazed white, which is absolutely guaranteed against breakage under all conditions of ordinary use.

Has a capacity of 1 gallon, with opening at top 3¼ inches in diameter, so that it can be used equally well for food or liquids. Will keep contents steaming hot or icy cold as long as any bottle made. Has substantial stopper and polished aluminum screw-top cap, which makes a good drinking cup. Ideal for touring, camping or picnicking.

Our Reduced Price
X8543—Each (ship. wt., 8 lbs.)..... **4.65**



White Ray Gasoline Lantern

Will light up your whole camp. Gives a pure white light of 300 candlepower—more light than 20 old-style oil lanterns. Outside, it is always ready for any job, any night in any weather. Hardest wind will not blow it out. Made of brass, nickel-plated. Inside, it is just the thing for reading. Burns own gas from common motor gasoline and costs only about a penny a night to use. Ship. wt., 6 lbs.

- K8101—White Ray Lantern..... **6.35**
- K8163—Extra Mantles per dozen **.95**

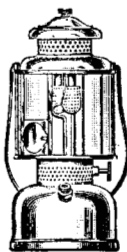

Tourist and Garage Lamp

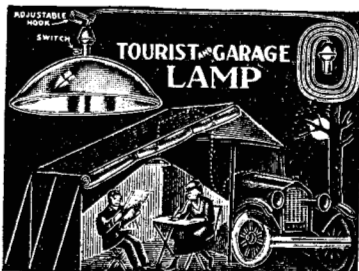

Consists of a specially designed reflector with bulb, 10 feet of wire and connecting plug that will connect with dash socket and let you have a good bright light in garage or on touring trip. Has special hook for hanging.

ing to top of inside of tent. Black enamel finish. Shipping weight, 21 lbs.

Our Reduced Price
C5806—Complete with 4 c. p. bulb..... **1.95**

Reserve Cans for Gasoline, Water or Oil

These cans will carry "enough to get you home." Made of strong galvanized iron with good seams. Either size will fit in space at end of Ford gas tank.

- K8105—½-gal. size (wt., 1½ lbs.)... **.60**
- K8106—1-gal. size (wt., 1¾ lbs.)... **.72**



Eskimo Thermic Jug

The Eskimo Thermic Jug consists of a one-gallon container, well-insulated and sealed in a steel jacket. It will keep ice 24 hours, hot liquids 12 hours and ice cream 10 hours. Has 3" opening, which permits cleaning. Top makes convenient drinking cup. Large opening at top makes it ideal for carrying butter, meat or any solid food. Swinging handle makes it easy to carry around. Just the thing for touring, camping, picnics, and general use. Non-porous—will not absorb or hold odors. **Absolutely guaranteed against breakage.** Ship. wt., 10 lbs.

X8538—One gallon size. **2.65**



Desert Water Bags

Keep water cool in sun or shade. The capillary attraction and evaporation does the work. These bags are double seamed and turned, eliminating the possibility of wear. Equipped so they can be tied to outside of car.

A5155 has solid top with spout and stopper. A5156 and A5157 have spout and stopper, also a patent metal fastener which releases entire top, allowing bag to be filled like a bucket or washed out easily.

- A5155—Regular Type, 2-gallon (wt. 21 lbs.)..... **1.10**
- A5156—Sanitary Type, 2 gallon (wt. 21 lbs.)..... **1.28**
- A5157—Sanitary Type, 3½-gallon (wt. 2½ lbs.).. **1.89**



Folding Pail and Basin

Substantially made of waterproof duck, with wire frame. Bucket has rope handle and wire strainer at nose. Basin is 9x9 inches, 4 inches deep.

- K8112—Folding Pail, 10-qt. (wt., 2 lbs.)..... **1.19**
- K8119—Folding Wash Basin (ship. wt., 1 lb.)..... **.85**



Electric Windshield Wiper

Works automatically off storage battery current and gives a constant wide sweep, regardless of engine speed. Has high-grade 1-40 H. P. motor, which uses about as much current as a dash bulb, even when working against rain, sleet or snow. **Noiseless in operation.** Wiper arm is adjustable to fit any windshield glass. Easy to install by drilling three holes on windshield frame. Complete instructions and all necessary wire and fittings furnished. Gears are packed in grease—will require no attention and last indefinitely. Absolutely guaranteed against defect. Ship. wt., 4 lbs.

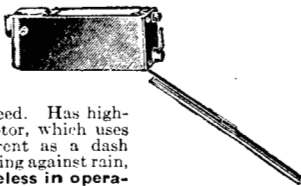

B5440—For 6-volt battery, complete. **5.85**

Radiator Shutters For Popular Cars

BEST COLD WEATHER RADIATOR PROTECTION

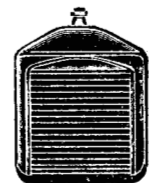

When closed, keeps out the cold and keeps in the warmth, making motor warm up more quickly and operate more efficiently; yet, when fully open, the air circulates freely, so that shutter may be left open during the warmer weather. Can be regulated to suit driving conditions. Operates from dash, so it is not necessary to get out of car to open or close it. Reduces to a minimum the chance of the radiator freezing. Permits easier starting—saves battery gas, oil, and radiator repair bills. Net and attractive, adding to appearance of the car. Comes ready to attach; easily and quickly installed by anyone; full instructions furnished. No complicated parts to get out of order—will last as long as the car. Shipping weight, 8 lbs.

X8937—For 1924 Ford cars. **7.95**
X8938—For Chevrolet Superior. **7.95**
X8939—For 1924 Dodge. **9.35**

Top Recoverings FOR FORD CLOSED CARS

Heavy rubberoid material, cut proper size and shape to replace worn or torn top cover on Ford closed cars. One-piece—no seams or joints. Easily installed by anyone; guaranteed to fit. If your top is torn or leaks, you can fix it yourself at a big saving by using one of these recoverings. Ship. wt., about 8 lbs.

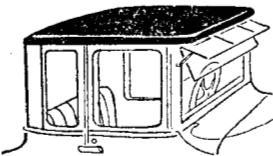

F6721—For Ford Coupe. **4.95**
F6722—For Two-door Sedan, 1915-23. **6.95**

"Pennant" Wind Deflectors

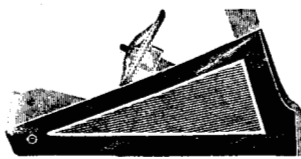

A substantial rubberoid strip which fastens on the windshield and extends back along the front door. Effectually prevents side drafts, yet affords clear vision and room for traffic signals. Center panel is made of heavy long grain vari-colored artificial leather, of an attractive red color. Very attractive as well as useful. Fit practically any car. Ship. wt., set, 3 lbs.

In ordering, give make and year of car.
F6687—Set of 2, as illustrated. **1.85**

Replacement Side Curtains FOR CHEVROLET 490 AND SUPERIOR

We can furnish high quality door-opening side curtains for Chevrolet 490 or Superior made of standard high-grade rubberized cloth with best quality celluloid lights. **In ordering, be sure to give year and model of car.**
W8344—Touring Side Curtains, regular style, for Chevrolet 490. **8.85**
W8345—Touring Side Curtains, door-opening style, for Chevrolet Superior. **11.85**
Furnished for other Chevrolet models on special order. Write for prices.

Furtex Radiator and Hood Covers FOR POPULAR CARS

This is an exceptionally well-made cover. Constructed of heavy black, long grained Dupont Raynite top material that is a very durable and will not break or crack. Lined with a good heavy felt lining. Made in two pieces, one covering the radiator proper and the other the hood. Front curtain rolls up and loops over radiator cap with special straps. Lower curtain rolls down so that door may be left entirely open. Extra well made. Strongly stitched. Best high-grade, strong snap fasteners. Corners of hood covers have pockets into which corner of hood may be inserted to hold cover on securely. Fits perfectly. By actual test this cover has shown a 25 per cent saving in gasoline. Keeps your motor warm. Makes easier starting. Saves time and money and makes it possible to drive your car in any kind of weather.

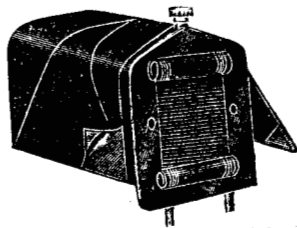

In ordering, be sure to give year and model of car. Shipping weight, 8 lbs.

K8245—Comp. Rad. & Hood Cover, 17-23 Fords. **2.95**
K8250—Radiator Cover only, 1917-23 Fords. **1.95**
K8251—Comp. Rad. & Hood Cover, 1924 Fords. **3.95**
K8252—Radiator Cover only, 1924 Fords. **1.95**

Genuine Frost King Hood and Radiator Covers

Similar to Furtex above, but better quality material and with a layer of **genuine asbestos** between the rubber and the felt.

K8241—Comp. Rad. & Hood Cover, 1917-23 Fords. **3.95**
K8243—Comp. Rad. & Hood Cover, 1924 Fords. **3.95**

Radiator Protector FOR FORD CARS

A high-grade rubberoid felt-lined protector which fits snugly over the front of the radiator to keep out the cold. Fastens through radiator core with bolts furnished. Is held in place at top with snap fasteners, so it can be detached and turned down to half-open position as shown in center of illustration. Ship. wt., 2 lbs.

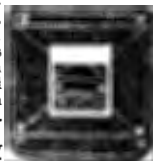

K8277—Radiator Protector for any model Ford, 1917-24. **.65**

Okeh Curtain Hangers For All Open Cars

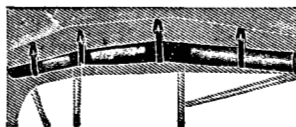

Lets you keep side curtains along the inside of your top, safe from loss or breakage and easily reached when needed. Slip around top pads. Not even necessary to unfasten top of curtains from car. Strong, simple, durable; neat in appearance and easy to install.

D6180—Complete, set of 8, (wt, 8 lbs.) **1.78**

188° Proof Denatured Alcohol FOR RADIATORS

Denatured alcohol has proved to be the most satisfactory preventive of frozen radiators. Easy to use and not injurious to cooling system. Because of market fluctuations we are unable to quote price, but carry highest quality 188° proof denatured alcohol in stock at all our stores. You will find our prices right and can depend on getting uniform standard quality. Drive up and put in what your radiator needs. We will also be glad to send quotations on request on lots of 10 gallons or more. Alcohol can not be sent by mail.

**Drafitte
STOPS DRAFTS
AROUND
FORD PEDALS**

The best device we have ever seen for this purpose.

Forms a complete housing around the foot pedals, fitting tight against the floor boards, so air is shut out. It bolts to the transmission housing, so that floor boards merely rest on it with enough tension to close the opening tightly and prevent rattling. Floor boards can be removed instantly without disturbing Drafitte in any way. Keeps out heat, cold, dust, gases and smells. Well made of heavy sheet steel, electric welded and finished in black japan—will outlast your car. Easily installed—only a screw driver needed. Full instructions furnished. Ship. wt., 3 lbs.



Our Reduced Price
B5381—Drafitte, complete. **1.35**

**Rubber Cold and Heat Mats
For Ford Cars**

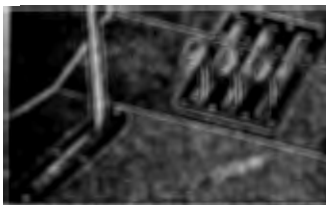

Keep out the cold air that comes in around the foot pedals in the winter and the hot air that comes in from the motor in the summer. Made of high quality rubber and will give long service. Can be attached by anyone in a

few minutes and once you have put on a set you would never be without them. Set includes protector around emergency brake lever, as well as around pedals. Ship. wt., 1 lb.
Our Reduced Price
G7094—Set, complete. **.68**

**Alweather Protector
FOR FORD CARS**

A very practical device that prevents the warm air in summer and the cold air in winter from blowing through the pedal openings on a Ford. Made of extra heavy padded felt, covered with artificial leather. Set includes protector around emergency brake lever, as well as around pedals.

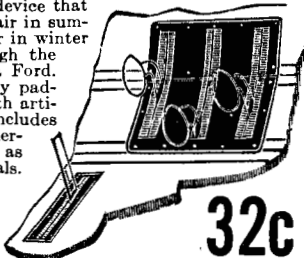

F6741—Complete set (Shipping weight, 8 oz.) **.32**

32c

Storm and Draft Shields

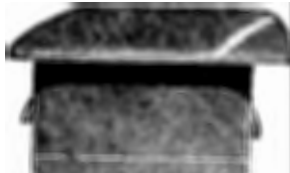

For Ford Cars

These shields close the space between the windshield and top of car and prevent wind and rain from beating through. F6689 fastens to the windshield by means of clips.

while F6688 slips down over the windshield as illustrated, thus giving it a better fit, preventing wind, rain and snow from coming in over the windshield. Made of best quality rubber-coated auto cloth. All fastenings included. Easily and quickly attached. Shipping weight, 1 lb.
F6680—Clip style (not illustrated). **.36**
F6588—Shield as shown. **.48**

Arctic Vaporizer for Ford

Makes Your Motor Start Easy in Coldest Weather

When you push the switch, the wires in the Vaporizer become hot, and, as the gas passes over them, it is heated, and consequently will explode easily when it reaches the firing chamber. Absolutely no danger and positively guaranteed to make your car start easier at all times. Comes complete with switch, necessary wiring and instructions. Can be installed by anyone in a few minutes. **Works off of storage battery, dry cells or Hot Shot Battery**, but will not work off of Ford magneto. Saves its cost in a short time by preventing waste of gasoline through unnecessary choking. Also prevents unburned gasoline from getting down in crank case to cause oil trouble. Shipping weight, 8 oz.

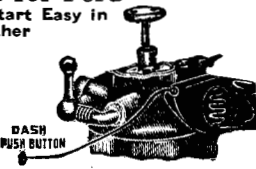

D6234—Complete with wire and switch (6 volt). 1.15

Aske Electric Fuemer

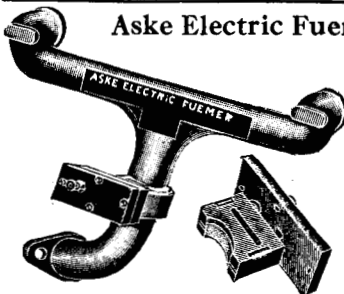

For Ford Cars

Takes just about three seconds to start the coldest Ford in the coldest weather with the Aske Electric Fuemer. Consists of a cast iron manifold which incorporates a heating element

using current from storage battery. So designed that stepping on starter pedal connects current and heats incoming gas fumes; turns off when starter is released. No separate switch necessary—current not used when running motor. Easily installed—simply replaces regular Ford manifold; only one wire to connect. Complete instructions furnished. Saves 75 per cent of your battery current, and doubles the life of your battery, besides avoiding the carbon and oil troubles caused when unvaporized gasoline gets into the cylinders. Fully Guaranteed—will last indefinitely. Ship. wt., 8 lbs.

Our Reduced Price
B5379—Aske Electric Fuemer, complete. **3.95**

Dunn Hot Dome Manifold

FOR CHEVROLET 490 AND SUPERIOR

Quickly stops the spitting noise made by the carburetor before the motor warms up. At the first few explosions, the Manifold Dome gets sizzling hot from exhaust gases passing through the Dome Cap. The spray of gas from the carburetor nozzle is forcibly thrown against this intensely hot dome and broken up completely, delivering dry, highly explosive gas to the cylinders.

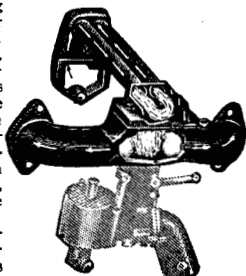

Starting is easy and mileage greatly increased. Factory tests obtained as high as 38 miles per gallon. No change in original controls. Easily installed. Full instructions furnished. Will soon pay for itself and last as long as the car. Ship. wt., 8 lbs.

J7779—Dunn Manifold for Chevrolet. **7.50**

Dunn Hot-Spot For Ford

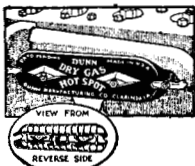

A time-tested device for utilizing the heat of the exhaust to heat the intake manifold, thus insuring complete combustion of gasoline, increasing power and mileage, preventing carbon formation and dilution of oil in the crank case. Easily installed, no machine work—only a wrench needed. Comes complete with instructions. Can be detached in a moment if desired. Soon pays for itself in gasoline and oil saved. Will outlast your car. Ship. wt., 4 lbs.

J7778—Dunn Hot-Spot for Ford. **.85**

**Super-Quality Car Heaters
FOR ANY OPEN OR CLOSED CAR**

Utilizes the hot gases from the engine exhaust to keep the car comfortably heated, even in the coldest weather. When open, part of the exhaust gases pass through the heater and escape under the car. No odor, no smoke, no dirt, no noise. The heating unit is of special cast metal with great heat radiating qualities, and has scientifically designed baffle plates to deflect the gases, eliminating all noise and back pressure, as well as increasing heating efficiency.

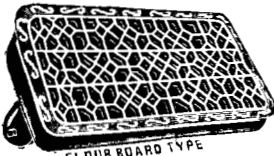

Furnished in two styles as illustrated. Rail type is raised above floor of car, while floor-board type is flush with it. This is the only flush type heater that can be taken apart and cleaned from inside the car. Heater is controlled by a simple, positive acting valve, mounted on the exhaust pipe, and controlled from the instrument board. Every heater comes complete with valve, flexible tubing, all necessary fittings and full instructions. Well made of best materials and will last indefinitely.

X8896—Rail type, about 14" long, 4" high, for Ford cars **5.85**
X8897—Rail type for Chevrolet, Overland and other small cars. **5.95**
X8898—Floor-board type, about 14x15 1/4 in., for any car..... **8.95**

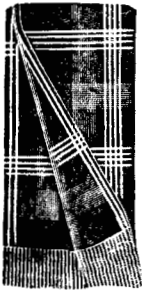

Winter King Motor Robes

Made of high-quality materials, dyed with fast colors. Very soft and closely woven, making ideal robes for motor use, to afford protection from wind and cold. Also very desirable for use around the home, as appearance and construction make it possible to use them like an Indian blanket.

- X8954**—Mixed wool robe, 52x70 in., no fringe (ship. wt., 4 1/2 lbs.)... **4.85**
X8955—All-wool robe, 54x76 in., with fringe (ship. wt., 4 lbs.)... **6.65**
X8956—All-wool robe, 54x76 in., with fringe (ship. wt., 5 lbs.)... **9.35**
X8957—All-wool robe, 56x80 in., with fringe (ship. wt., 4 1/2 lbs.)... **10.85**

**Hot-Wave Car Heaters—Floor Type
FOR FORD, CHEVROLET, OVERLAND AND STAR**



Carries the heat to the feet of persons sitting in the front seat. Register plate is in floor board and not the dash, as in most heaters. Shutter at register plate may be opened or closed with the foot. When the heaters is closed, the heat passes out through an opening under the car and does not back up against the manifold and overheat the motor in warm weather as most heaters do.

Furnishes plenty of heat to keep occupants of car warm on coldest days. Works very quickly, as heat begins to roll into car within thirty seconds after starting motor. Can be installed by anyone in a few minutes. No cutting of dash or exhaust pipe necessary. Complete instructions furnished. Strongly made and well finished. Shipping weight 11 lbs.

- Our Reduced Price**
W8469—Heater complete for Ford..... **1.38**
W8448—For Chevrolet 490 and Superior..... **3.20**
W8470—Heater complete for Overland 4..... **2.45**
W8471—Heater complete for Star..... **2.10**

**Hot-Wave Heaters—Dash Type
FOR FORD AND DODGE CARS**

Work on the same principle as a hot-air furnace. A strong, substantial cover surrounds the exhaust manifold, so that air passing through this chamber into the car is heated as it goes through. Nothing but warm fresh air enters car—no danger from gases or fumes. Illustration shows how damper is used to deflect the heat down on your feet, or shut it off altogether. Finished in black enamel. Installed through dash; full instructions furnished. Shipping weight, 8 lbs.

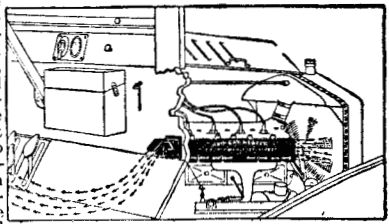

- Our Reduced Price**
W8447—For any model Ford car..... **1.19**
W8472—For Dodge cars..... **4.15**

GENUINE WALRATH MOTOR GLOVES

FOR THE MAN WHO WANTS THE BEST

Walrath gloves are the standard glove of the motor world. Highest grade workmanship, ensuring proper fit and durability. Materials as described below, for various styles. Average shipping weight, 3 lbs. per pair.

X8900 (No. 107)—Men's black gauntlet glove. Made of good heavy leather, has genuine leather cuff and wrist strap. Lining is warm wool fleece and cuff is of limp leather so that glove may be rolled up and easily carried in pocket. **2.95**
X8901 (No. 107-1F)—One finger mitten, same quality as X8900. **2.95**
X8902 (No. 107-M)—Regular style mitten, same quality as X8900. **2.95**
X8903 (No. 97)—Same as X8900, except it is short glove and has no gauntlet..... **2.55**
X8904 (97-1F)—One finger mitten, same quality as X8903..... **2.55**



- X8905** (No. 97-M)—Regular style mitten, same quality as X8903. **2.55**
X8906 (No. 101)—Black Gauntlet Glove. Leather slightly heavier than X8900; has leather cuff and is angora lined. Can be rolled up and carried in pocket. **3.75**
X8915 (No. 385-NB)—Brown glove, no gauntlet, button top, fleece lined. **1.95**
X8907 (No. 255)—Black gauntlet glove, made of finest leather. Has large limp leather cuff and is complete with wrist strap. Finest wool fleece lining. Has large patch on palms and thumbs, making this part double thickness and giving it long wearing qualities. **4.25**
X8908 (No. 295)—Black gauntlet glove. Has large semi-limp leather cuff made of finest leather with wrist strap. Lined with fine genuine lamb's fur, warmest lining obtainable..... **5.95**
- X8909** (No. 295-1F)—One finger mitten, same quality as X8908. **5.95**
X8910 (No. 295-M)—Regular style mitten, same quality as X8908. **5.95**
X8911 (No. 293)—Same as X8908, except short glove, no gauntlet. **5.45**
X8912 (No. 293-1F)—One-finger mitten, same quality as X8911..... **5.45**
X8913 (No. 293-M)—Regular style mitten, same quality as X8911..... **5.45**
X8914 (No. 267-NB)—Made in beautiful brown or cordovan color, best grade leather. Has limp brown gauntlet, lined with gray flexible leather. Hand of glove is lined with fine wool cloth. **6.35**

INDEX

ARTICLE	PAGE	ARTICLE	PAGE	ARTICLE	PAGE	ARTICLE	PAGE
Accelerators, Foot	23	Dry Cells	52	Moto Wings	72	Steering Column Braces	78
Alumite System & Parts	70	Dusters & Dust Cloths	53	Mounting for Run. Bds.	73	Steering Devices	78
Ammeters	92	Electrician's Tool Kit	50	Muffler & Parts	67-68	Securing Wheels	29-37
Anti-Rattlers	10-89-81-118	Emery Cloth	59	Neatsfoot Compound	56	Securing Wheel Locks	29
Asbestos Larn & Packing	23	Enamels	60-61	Non-Kick Devices	18	Step Plates	25
Arm Hests	23	Encyclopedia, Dyke's	119	Nut & Bolt Holders	109	Stools & Chairs	122-123
Ash Receivers	32-79	End Armst. Bearings	68	Nuts & Cap Screws	103	Stop Cocks	52
Axes, Camp	120	End Wrenches	119-111	Oils & Greases	67-69-69-70	Stop Lock for Kaurator	74
Axle Braces	80	Exhaust Deflectors	67	Oil Cans & Holders	67	Stop Signals	43-45
Axle Shafts	90-117	Exhaust Horns	34	Oil Cups	69	Stoves & Grates	6
Axle Shims	19	Eye Belts	100	Oil Gauges	66-71	Stove Bolts	103
Babbitt and Babb. Jig	77	Fans & Parts	76-97	Oiling System for Ford	66	Straps & Loops	21
Ball Bearings	71-87	Fan Belt Guide	76	Oil Saver for Ford	97	Switches & Keys	50-51
Ball Shim	81	Fan Belting & Fasteners	101	Paints & Outfits	60-61	Tables, Folding	122
Ball Thrusts	68-87	Fan Pulleys	70-97	Paints & Varnish Brushes	61	Tail Lamps and Lens	43
Batteries	62 to 65	Felt Gaskets & Washers	99	Paint Remover	61	Tap & Die Sets	115
Battery Boxes	63	Fenders & Parts	23-38	Parking Lamps	14-15	Tap & Drill Sets	115
Battery Chargers	46	Fender Brushes	58	Patches	12-13-14-31	Tapet, Friction	46
Battery Covers	63	Fender Fixers	80-81	Patenting Cement	14	Tappet Wrenches	105
Batt. Clips & Terminals	62	Files & Handles	116	Pedal Pads	23-24	Tekalite	47
Battery Testers & Filers	63	Fire Cups	55	Pipe Wrenches	110	Tents	121
Bearing Adjusters	68-77	Flashlights	121	Pistons & Rings	88-89	Thermal Jugs & Juts	124
Bearing Compound	104	Floot, Stewart Vacuum	52	Piston Ring Compressors	88	Thickness Gauges	105
Bearing Screws & Blue	104	Ford, Stewart Vacuum	52	Piston Ring Expanders	88	Throttle Linkages	33-37
Bears, Auto and Camp	83	Ford Rests & Mats	24	Pliers	108	Tinner Wires	148-149
Belting & Couplings	101	Form-a-Gasket Comp.	89	Pushes	43-59	Timing Gears	82-83
Bentails & Parts	98	Funnels & Measures	68	Printing Cups	52	Tire Carriers	15
Blow-out Patches	13	Garage Door Brace	87	Pump Connections	16-17	Tire Chain Fasteners	18
Blow Torches	102-103	Garage Lamps	124	Pumps & Repairs	16-17	Tire Chains (Non-Skid)	18
Body Rails	33	Gasket Cement	99	Pump Hose & Tubing	109	Tire Covers	21
Books & Maps	119	Gaskets	58-93-90	Punches	109	Tire Cut Filler	2 to 15
Boots, Tire	12-13	Gasoline Gauges	71-118	Push Rods	93-118	Tire Flaps	25
Bow Covering Material	63	Gas Saver	53	Radiators & Parts	75-97	Tire Gauges	15
Boye-It	53	Gas Tank Caps	71-92-117	Radiator Caps	72-73	Tire Irons	14-18
Brake Juice & Waters	82	Gauges, Oil	66-71	Radiator Compounds	74	Tire Locks & Chains	21
Brakes & Shoes	83	Gauges, Tire	16	Radi. Covers & Shutters	124	Tools	105 to 118
Brake Shoe Adjusters	83	Gear Pullers	113	Radiator Hose	74	Tool Boxes	118
Brake Lining	84-85	Gear Shift Extensions	117	Radiator Ornaments	72-73	Tool Patches	30
Brake Lites	85	Generator Parts	51-98	Radiator Shell for Ford	21	Top Pads & Material	30
Brightening	58-61-98	Glare Shields	40	Radiator Supports	74	Top Patches	31
Bulbs, Electric	39	Gl-Lites	73	Radiator Batteries	63	Top Protectors	30
Bumpers	25-36-37	Gloves	127	Railroad Rods & Braces	80-92	Top Straps & Springs	33
Bushing Removers	109	Glue, Waterproof	31	Rain Guards	109	Top Supports	33
Cable, Lighting & Ign.	46-47	Graphite & Grease	68	Reamer	129	Tops & Receivers	28-29-125
Camp Equipment	119 to 124	Gratings	122	Rear Curtains	28-30	Top Webbing	30
Cap Grease	104	Grease Cups	66-67	Rear Wheel Retainer	19	Tow Ropes	122
Carburetor Removers	104	Grease Guns	70	Rebound Checks	38	Trans. Band Adjusters	84
Carburetor Adjusters	52-53	Grease Retainers	67-99	Receivers & Taps	28-29-125	Trans. Band Oilers	83
Carburetors & Parts	52-53	Greases & Oils	68-69-70	Reflectors & Polish	43	Trans. Band Tools	84
Carpets for All Cars	24	Grinders, Tools	115	Reinforc. Tire	12-13	Trans. Linings	85
Carrying Bags	26	Hack Saws & Blades	114	Repair Parts	90 to 98	Trans. Lamps	129
Celluloid	29	Hammers	109	Repair Metal	102	Trunk Racks	47
Cements	12-14-74-99	Handles, Locking Door	20	Rims & Parts	129	Tubes	9-10-11
Chains & Parts, Tire	18-19	Headlamps & Parts	127	Rim Cup Hooks	14	Tube Patches	14
Chairs	58	Heater Cars	127	Rim Point	55	Tube Protectors	15
Chains, Folding	122-123	Heel Plates & Rests	23	Rim Wrenches & Tools	19-22	Tubing, Flexible	52
Chatter Cures for Fords	82	Higo Chatter Cure	82	Ribs	84	Unions	123
Chevrolet Specials	118	Hood & Parts	98	Roller Bearings	77-87-90-92	Upolstering Assemblies	32
Cigar Lighters	79	Hood & Rad. Covers	125	Router Books & Maps	119	Upolstering Tapp. etc.	31
Choke-holds	109	Hood Clamps	80-81-113	Rubber Bumpers	33	Valves, Engine	93-105
Choker Springs	66	Horns & Horn Buttons	35	Rubber Mallets	24-25	Valve Adjusters	103
Clocks, Auto	79	Hot Air Clamps	17-24	Rubber Mops	116	Valve Grinders	106
Clutch Facing	118	Hose, Radiator	74	Running Board Braces	82-98	Valve Grinding Comp.	107
Coil Boxes & Parts	50	Hot Shot Batteries	62	Safety Light Plugs	59	Valve Insides (cores)	16
Coil Point Files	51	Hubs & Caps	19-92-118	Sand Paper	59	Valve Lifters	105
Cold & Cell. Pumps	48-50	Hub Cap Wrenches	109	Saw Drivers	50	Valve Reamer Guide	105
Cold & Heat Mats	126-129	Hydrometers	63	Screw Extractors	115	Valve Refacers	106-107
Compass, Pocket	119	Ignition Gauges	55	Screws, Wood	103	Valve Stem Packing	105
Connecting Rods	86	Ign. System for Ford	48	Seat Covers	26-27	Valve Tools, Tire	16
Copper Tubing	52	Inner Tires	12	Seat Mats	122	Vaporizers	126
Cork & Cork Gaskets	99	Iron Cement	101-102	Set Screws	122	Varnishes & Paints	56-57
Cots and Beds	123	Jacks	22	Shellac	74-99	Vases, Flower	128
Cott. Pins & Extractors	103	Keystainers	59	Shims & Shim Stock	101	Ventilators	116
Counterbalances	86	Kick Plates	25	Shock Absorbers	38	Visors	41
Covers, Automobile	120	Lamps	39 to 45-124	Shutters for Radiators	125	Volt-meters	62
Crank Case Arms	82-94	Lamp Parts	43-51	Side Curtains	125-129	Voltmeters	12
Crank Holders	37	Lanterns	123	Side Lamps	44	Vulc. Rubber & Cement	12
Crank Pins for Ford	75	Lenses	17	Simoniz	53	Washers, Felt	99
Crank Shafts	86-93	License Plates	17	Skillets, Folding	129	Waste, Cotton	58
Crank Wrenches	114	Light Plugs & Sockets	51	Soaps	53-60-120	Water Bags & Cans	124
Cup Grease	66	Lining Dye	61	Sockets, Electric	51	Water Circulators	76
Curtains	30-32-125-129	Lindoleum for Run. Bds.	33	Socket Wrenches	119 to 113	Waterproof Compound	61
Curtain Fasteners	120	Locking Steering Wheels	20	Socket Wrenches	119 to 113	Weatherstrips	61
Curtain Lights	31	Lock Washers	103	Solder & Soldering	109	Wheels & Parts	19-92
Cushions	26-30	Loosen Nut Compound	101	Soldering Flux & Paste	109	Wheel Pullers	113
Cushion Dressing	30	Luggage Carriers	120	Soles, Auto	190	Whistles	34
Cuts, Generator	51	Magneto Plugs	66	Spoke Plugs & Cores	76-77	Window Glass	40
Cutouts, Muffler & Parts	54	Manifolds for Fords	93-125	Spoke Plug Transmitters	55	Windshields & Parts	40
Cyl. Head Gaskets	90-117	Manifold Gaskets	92-99	Spoke Plug Wires	46	Windshield Cleaners	41-125
Cylinder Lapping Comp.	107	Maps & Guides	119	Spoke Plug Wrenches	55	Windshield Glass	40
Dashes & Brackets	98	Master Torq	46	Spoolometers & Parts	79	Windshield Rubber	40
Dash Lamps	47	Mastic, Michelin	15	Spoolies for Fords	78-91	Windshield Wings	40-42-125
Dash Control	54	Mats, Floor	24	Spoke Shims	15	Winter Goods	125 to 129
Dome Lamps	54	Metal Polish	50	Spoke-Tite	19	Wire, Ironfilon	46-47
Door Check Straps	73	Mica Powder	23	Sponges	58	Wire, Plain	101
Door Handle Extensions	73	Mile Maker Tablets	53	Spotlights	42	Wiring Systems, Ford	46
Door Pull Handle	73	Mirrors	24	Springs & Parts	86-87-97	Wunderlifter	46
Door Latches & Locks	90-93	Motometers and Locks	72-73	Spring Oil & Others	86	Wrenches	58-105-109 to 114
Door Pockets & Pads	90-93	Motor Cyls.	87	Spring Shackles	86	Wrench for Dodge & Chevrolet	114
Drainage	126	Motor Cyls. Ford	82-118	Starting Parts	98	Wrench Sets	105-111-112-118
Drain Coeks	96	Motor-Turner-Fone	77	Steel Wool	50		
Drain Cock Wrenches	71-114						
Drills	117						
Drive Shafts	97						
Drive Shaft Tube Supp.	77						

DOOR-OPENING SIDE CURTAINS

FOR FORD CARS

Door-opening side curtains for front or rear, built over a simple hinged rod frame that can be opened or closed with either door, adding comfort and convenience to Ford cars. No more smashed hats and loss of time trying to crawl under curtains in entering or leaving car; no more loose curtains flapping around and hitting you in the face; no more delays of unfastening and fastening curtains; keep out the cold wind, rain, snow or dust.

Neat in appearance, simple in construction, well made. Made of heavy 32-oz. black rubber cloth to match regular Ford top or present curtains. Clear celluloid windows. Carefully finished.

Nothing to get out of order; quickly and easily attached by anyone. Fit right on where old curtains are taken off. Come complete with all necessary screws and fasteners, irons and instructions. In complete set for Touring car, right front and right rear are door opening curtains, left curtains are regular style. Ship. wt., each, 5 lbs. Touring set, 17 lbs. Roadster set, 12 lbs. Be sure to state year of car, and whether for Touring or Roadster.

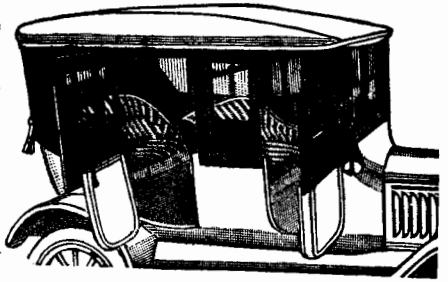

For 1915-22 Fords

- E6524—Complete set, Ford Touring, 1915-22 . . . 7.95
- E6525—Complete set, Ford Roadster, 1915-22 . . . 4.95
- F6670—Single Curtain, right front door, Touring, . . . 2.95
- F6671—Single Curtain, right rear door, Touring, . . . 2.95
- F6673—Single Curtain, for Roadster, right front, . . . 2.95

For 1923-24 Fords

- E6528—Complete set, Ford Touring, 1923-24 . . . 7.95
- E6529—Complete set, Ford Roadster, 1923-24 . . . 4.95
- F6674—Single Curtain, right front door, Touring, . . . 2.95
- F6675—Single Curtain, right rear door, Touring, . . . 2.95
- F6672—Single Curtain, right front, Roadster, . . . 2.95

Pedal Sleeves For Fords

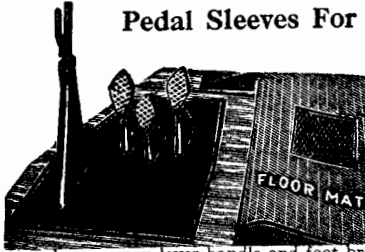

Keep out the hot air in summer and the cold air in winter around the brake lever and foot pedals. Made of strong fabric and so designed that it snaps securely around emergency lever handle and foot brakes, and prevents the cold from coming in, no matter in what position the pedals are. This keeps your feet warm and makes winter driving much more pleasant. Comes complete ready to put on.

Our Reduced Price

- F6729—Complete set (Ship. wt., 1 lb.) 89

Side Curtains for Ford Cars

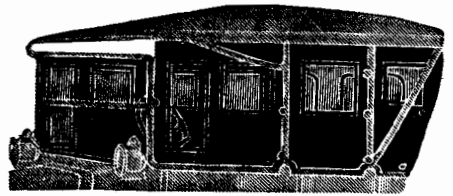

Regular style side curtains, easily attached by anyone. Strongly made of best heavy rubber-coated auto cloth to match top, with large panels of best celluloid. Touring curtains are furnished separate or in complete sets. In ordering one curtain only, be sure to state which side you want it for—right or left side; also give year of car. Furnished for all model Ford cars. Shipping weight single curtain, 3 lbs.; set Touring, 8 lbs.; set Roadster, 5 lbs.

FOR 1915-22 FORD CARS

- F6662—Right Front Curtain, Tour., 1915-22, ea. 1.70
- F6663—Right Rear Curtain, Tour., 1915-22, ea. 1.95
- F6664—Left Front Curtain, Tour., 1915-22, ea. 1.70
- F6665—Left Rear Curtain, Tour., 1915-22, ea. 1.95
- F6660—Complete set Roadster, 1915-22 3.65
- F6661—Complete set Touring, 1915-22 5.65

FOR 1923-24 FORD CARS

- E6464—Right Front Curtain, Tour., 1923-24, ea. 1.70
- E6465—Right Rear Curtain, Tour., 1923-24, ea. 1.95
- E6466—Left Front Curtain, Tour., 1923-24, ea. 1.70
- E6467—Left Rear Curtain, Tour., 1923-24, ea. 1.95
- E6468—Complete set Touring, 1923-24 5.65
- E6469—Complete set Roadster, 1923-24 3.65

Freeze-Meter



For testing the mixture of alcohol and water in the cooling system, thus preventing frozen radiators and cracked cylinders. To use, simply remove radiator cap and draw enough liquid from your radiator to lift the float. The water level on the float will show the temperature at which the solution will freeze. Graduated to 38 degrees below zero.

- B5519—Each complete (Ship. wt., 8 oz.) 49
- B5518—Extra float for Freeze-Meter 24

Radio Suggestions

Articles that are most necessary for building or repairing radio sets.

GUARANTEED QUALITY—MONEY-SAVING PRICES.

BATTERY SUPPLIES

Dry Cell Batteries	Page
Hot Shot Batteries	62
Radio Storage Batteries	63
Battery Chargers	63
Battery Test Clips	63
Battery Terminals	62
Battery Filler	62
Hydrometers	62
Ammeters and Voltmeters	62

MISCELLANEOUS SUPPLIES

Insulated Wire	46 & 47
Friction Tape	46
Insulating Staples	46
Brass Shim Stock	101
Switches	51
20-gauge Copper Wire	101
Shellac	74

SOLDERING SUPPLIES

Soldering Irons	Page
Electric Soldering Iron	102
Soldering Paste	103
Solder, Wire or Bar	102
Acid Core Solder	102
Automatic Blow Torch	102

TOOLS

Diagonal Cut Pliers	108
Hand Drills	115
Drill Bits	115
Handy Clamp Vises	116
Screwdrivers	108
Baby Screwdriver	50
Hack Saws and Blades	114
Needle Nose Pliers	108
Electricians' Tool Kit	50
"Mr. Punch" Automatic Drill	115

2c PAID

KANSAS CITY, MO.
PERMIT No. 48

For

NO POSTAGE
NECESSARY
IF MAILED
IN THE
UNITED STATES

POSTMASTER~RETURN POSTAGE GUARANTEED

Save
20% to
50%

See
Our Special
Tire Prices
Pages 2 to 7

Western Auto Supply Co.

Kansas City

1422-1424 GRAND AVE.

KANSAS CITY, MO.
DALLAS, TEXAS
ATLANTA, GA.
HOUSTON, TEXAS

ST. PAUL, MINN.
DES MOINES, IA.
WICHITA, KANS.
TOPEKA, KANS.